

Ericsson GSM System, BSS R7

RBS 2301, RBS 2302, RBS 2401, Maxite™ Reference Manual

ERICSSON 

LZN 302 77 R7A

Reference Manual

© Ericsson Radio Systems AB — All Rights Reserved —

Due to continued progress in methodology, design and manufacturing, the contents of this document are subject to revision without notice.

Contents

| | |
|--|-----------|
| 1 Preface | 15 |
| 1.1 Objectives..... | 15 |
| 1.2 Audience..... | 15 |
| 1.3 MAXITE [™] Trademark..... | 15 |
| 1.4 Customer Documentation Library..... | 16 |
| 1.5 Release History..... | 16 |
| 2 Product Safety Requirements RBS 2000 | 19 |
| 2.1 References..... | 19 |
| 2.2 Product Safety..... | 19 |
| 3 Building Practice Requirements RBS 2000 | 21 |
| 3.1 Fire Resistance..... | 21 |
| 3.2 Poisonous Fumes..... | 22 |
| 3.3 Declaration of Materials..... | 22 |
| 3.4 Silicone..... | 22 |
| 3.5 Environmental Consideration during the Life-Cycle..... | 22 |
| 4 Environmental Capabilities | 23 |
| 4.1 Scope..... | 23 |
| 4.2 Terminology..... | 23 |
| 4.3 References..... | 24 |
| 4.4 Transport -40 °C - +70 °C..... | 24 |
| 4.5 Storage -25 °C - +55 °C..... | 25 |
| 4.6 Handling -40 °C - +70 °C..... | 27 |
| 4.7 Operation Mast Mounted Equipment -33 °C - +55 °C..... | 27 |
| 4.8 Operation Indoor +5 °C - +40 °C..... | 29 |
| 5 Site Configurations, RBS 2000 Micro | 33 |
| 5.1 Terminology..... | 33 |
| 5.2 System Overview..... | 33 |
| 5.3 Power Consumption..... | 37 |
| 5.4 Configuration..... | 40 |

| | | |
|----------|--|-----------|
| 6 | Site Configurations, RBS 2000 Small Indoor | 55 |
| 6.1 | Terminology | 55 |
| 6.2 | System Overview | 55 |
| 6.3 | Configuration | 56 |
| 7 | Radio Configurations, RBS 2000 Micro | 59 |
| 7.1 | References | 59 |
| 7.2 | Terminology | 59 |
| 7.3 | Frequency Bands | 62 |
| 7.4 | General | 62 |
| 7.5 | Configurations | 62 |
| 7.6 | Basic Configuration GSM 900 MHz, M9d_2.2 | 68 |
| 7.7 | Basic Configuration GSM 900 MHz, M9d_1.2 | 70 |
| 7.8 | Basic Configuration M9d_2.2\C | 71 |
| 7.9 | Basic Configuration GSM 900 MHz, M9d_2.2\H | 72 |
| 7.10 | Basic Configuration GSM 1800 MHz, M18d_2.2 | 73 |
| 7.11 | Basic Configuration GSM 1800 MHz, M18d_1.2 | 75 |
| 7.12 | Basic Configuration GSM 1800 MHz, M18d_2.2\A | 76 |
| 7.13 | Basic Configuration GSM 1800 MHz, M18d_2.2\H | 77 |
| 7.14 | Basic Configuration GSM 1900 MHz, M19d_2.2 | 78 |
| 7.15 | Basic Configuration GSM 1900 MHz, M19d_1.2 | 80 |
| 7.16 | Basic Configuration GSM 1900 MHz, M19d_2.2\A | 81 |
| 7.17 | Basic Configuration GSM 1900 MHz, M19d_2.2\H | 82 |
| 8 | Radio Configurations, RBS 2000 Small Indoor | 83 |
| 8.1 | References | 83 |
| 8.2 | Terminology | 83 |
| 8.3 | Frequency Bands | 84 |
| 8.4 | General | 84 |
| 8.5 | Configurations | 84 |
| 8.6 | Basic Configuration GSM 900, M9d_1.2\1 | 86 |
| 8.7 | Basic Configuration GSM 1800, M18d_1.2\1 | 87 |
| 9 | Product Specification for RBS 2301 | 89 |

| | | |
|-----------|--|------------|
| 9.1 | General..... | 89 |
| 9.2 | Product Architecture..... | 91 |
| 9.3 | Configuration..... | 93 |
| 9.4 | Combinations..... | 95 |
| 9.5 | Transmission Modes..... | 95 |
| 9.6 | Interface and Connection..... | 96 |
| 9.7 | Product Requirements..... | 98 |
| 10 | Product Specification for RBS 2302..... | 105 |
| 10.1 | Terminology..... | 105 |
| 10.2 | General..... | 105 |
| 10.3 | Product Architecture..... | 107 |
| 10.4 | Configurations..... | 111 |
| 10.5 | Combinations..... | 113 |
| 10.6 | Transmission Modes..... | 113 |
| 10.7 | Interface and Connection..... | 115 |
| 10.8 | Product Requirements..... | 117 |
| 11 | Product Specification for RBS 2401..... | 125 |
| 11.1 | Terminology..... | 125 |
| 11.2 | General..... | 126 |
| 11.3 | Product Architecture..... | 128 |
| 11.4 | Configurations..... | 128 |
| 11.5 | Combinations..... | 129 |
| 11.6 | Transmission Modes..... | 129 |
| 11.7 | Interfaces and Connections..... | 130 |
| 11.8 | Product Requirements..... | 132 |
| 12 | Product Specification for Power and Battery Cabinet | 139 |
| 12.1 | Terminology..... | 139 |
| 12.2 | General..... | 139 |
| 12.3 | Product Architecture..... | 140 |
| 12.4 | Configurations..... | 141 |
| 12.5 | Combinations..... | 141 |

| | | |
|-----------|--|------------|
| 12.6 | Interface and Connection | 142 |
| 12.7 | Product Requirements | 145 |
| 13 | Product Specification for 500 W Active Antenna Unit..... | 155 |
| 13.1 | Terminology | 155 |
| 13.2 | General | 155 |
| 13.3 | Product Architecture - Main Physical Units, GSM 1800 (500 W)..... | 157 |
| 13.4 | Product Architecture - Main Physical Units, GSM 1900 (500 W)..... | 167 |
| 14 | Product Specification for 1250 W Active Antenna Unit..... | 177 |
| 14.1 | Terminology | 177 |
| 14.2 | General | 177 |
| 14.3 | Product Architecture | 179 |
| 14.4 | Configurations | 179 |
| 14.5 | Interface and Connection | 180 |
| 14.6 | Product Requirements | 181 |
| 15 | Product Specification for Coverage Extension Unit..... | 189 |
| 15.1 | Terminology | 189 |
| 15.2 | General | 189 |
| 15.3 | Product Architecture - Main Physical Units, GSM 900 | 190 |
| 16 | EMC Capabilities for RBS 2301 | 199 |
| 16.1 | References | 199 |
| 16.2 | Concepts | 200 |
| 16.3 | Capabilities | 201 |
| 17 | EMC Capabilities for RBS 2302 and MaxiteTM | 207 |
| 17.1 | References | 207 |
| 17.2 | Concepts | 209 |
| 17.3 | Emission | 211 |
| 17.4 | Immunity | 214 |
| 18 | EMC Capabilities for RBS 2401 | 225 |
| 18.1 | References and Concepts | 225 |
| 18.2 | Emission | 225 |

| | |
|--|------------|
| 18.3 Immunity | 225 |
| 19 Broadcast..... | 231 |
| 19.1 References..... | 231 |
| 19.2 Concepts..... | 231 |
| 19.3 Functions..... | 231 |
| 20 Common Control Channel Handling..... | 235 |
| 20.1 References..... | 235 |
| 20.2 Function..... | 235 |
| 20.3 Operational Conditions..... | 240 |
| 21 Physical Channel Handling..... | 241 |
| 21.1 References..... | 241 |
| 21.2 Functions..... | 241 |
| 22 Speech and Data Services..... | 245 |
| 22.1 References..... | 245 |
| 22.2 Concepts..... | 245 |
| 22.3 Functions..... | 246 |
| 22.4 Operational Conditions..... | 250 |
| 23 Call Control..... | 253 |
| 23.1 References..... | 253 |
| 23.2 Channel Activation..... | 253 |
| 23.3 Adaptive Frame Alignment..... | 257 |
| 23.4 Asynchronous Handover Detection..... | 258 |
| 23.5 RF Channel Release | 260 |
| 23.6 Deactivate SACCH..... | 261 |
| 23.7 Link Establish Indication..... | 261 |
| 23.8 Link Release Indication | 263 |
| 23.9 Link Establishment Request..... | 264 |
| 23.10 Link Release Request | 264 |
| 23.11 Transparent Message Transmission..... | 265 |
| 23.12 Transparent Message Reception | 266 |
| 23.13 SACCH Info Modify..... | 267 |

| | | |
|-----------|---|------------|
| 23.14 | LAPDm..... | 268 |
| 23.15 | Channel Reactivation..... | 269 |
| 23.16 | Power Information..... | 273 |
| 24 | Base Station Power Control..... | 275 |
| 24.1 | References..... | 275 |
| 24.2 | Concepts..... | 275 |
| 24.3 | Functions..... | 275 |
| 24.4 | Operational Conditions..... | 276 |
| 25 | Channel Measurements..... | 277 |
| 25.1 | References..... | 277 |
| 25.2 | Concepts..... | 277 |
| 25.3 | Functions..... | 277 |
| 25.4 | Operational Conditions..... | 279 |
| 26 | Discontinuous Transmission..... | 281 |
| 26.1 | References..... | 281 |
| 26.2 | Functions..... | 281 |
| 27 | Encryption..... | 285 |
| 27.1 | References..... | 285 |
| 27.2 | Start Encryption at Channel Activation..... | 285 |
| 27.3 | Encryption Mode Change..... | 286 |
| 27.4 | Encryption Mode Change at Mode Modify..... | 287 |
| 28 | Frequency Hopping..... | 289 |
| 28.1 | References..... | 289 |
| 28.2 | Concepts..... | 289 |
| 28.3 | Function..... | 289 |
| 28.4 | Operational Conditions..... | 290 |
| 29 | Mode Modify..... | 291 |
| 29.1 | References..... | 291 |
| 29.2 | Function..... | 291 |
| 29.3 | Operational Conditions..... | 293 |
| 30 | Mobile Station Power Control..... | 295 |

| | | |
|-----------|--|------------|
| 30.1 | References..... | 295 |
| 30.2 | Functions..... | 295 |
| 31 | Short Message Service..... | 297 |
| 31.1 | References..... | 297 |
| 31.2 | Functions..... | 297 |
| 31.3 | Operational Conditions..... | 299 |
| 32 | Diversity Supervision..... | 301 |
| 32.1 | References..... | 301 |
| 32.2 | Concepts..... | 301 |
| 32.3 | Function..... | 302 |
| 32.4 | Operational Conditions..... | 303 |
| 33 | Synchronization..... | 305 |
| 33.1 | References..... | 306 |
| 33.2 | Concepts..... | 307 |
| 33.3 | Synchronizing to the Reference Source..... | 307 |
| 33.4 | Selection of the Reference Source..... | 308 |
| 33.5 | Hold-Over Operation..... | 309 |
| 33.6 | Supervision of Reference Source..... | 310 |
| 33.7 | Locking to the Reference Source..... | 311 |
| 33.8 | FN-Offset..... | 312 |
| 33.9 | ESB Distribution..... | 312 |
| 33.10 | Timing Compensation..... | 312 |
| 34 | Radio Reception..... | 315 |
| 34.1 | References..... | 315 |
| 34.2 | Radio Reception..... | 315 |
| 34.3 | Diversity..... | 315 |
| 35 | Radio Transmission..... | 317 |
| 35.1 | References..... | 317 |
| 35.2 | Concepts..... | 317 |
| 35.3 | Functions..... | 318 |
| 35.4 | Operational Conditions..... | 319 |

| | | |
|-----------|--|------------|
| 36 | Frequency Allocation Support | 321 |
| 36.1 | References | 321 |
| 36.2 | Concepts | 321 |
| 36.3 | Functions | 321 |
| 36.4 | Operational Conditions | 323 |
| 37 | Restart and Recovery | 325 |
| 37.1 | References | 325 |
| 37.2 | Concepts | 325 |
| 37.3 | Function | 326 |
| 37.4 | Operational Conditions | 327 |
| 38 | Function Change | 329 |
| 38.1 | Concepts | 329 |
| 38.2 | Functions | 330 |
| 38.3 | Operational Conditions | 332 |
| 39 | Functionality Administration | 333 |
| 39.1 | References | 333 |
| 39.2 | Concepts | 333 |
| 39.3 | Functions | 334 |
| 39.4 | Operational Conditions | 337 |
| 40 | Operation and Maintenance Support | 339 |
| 40.1 | References | 339 |
| 40.2 | Concepts | 339 |
| 40.3 | Buttons | 341 |
| 40.4 | Change RU to Local Mode | 341 |
| 40.5 | Change RU to Remote Mode | 342 |
| 40.6 | Change RU to Remote Mode Cancel | 343 |
| 40.7 | Loop Control | 343 |
| 40.8 | RF Loop Test Supervision | 343 |
| 40.9 | Calendar Time Request | 344 |
| 40.10 | RSSI Temperature Compensation | 344 |
| 40.11 | Fault Indicator | 345 |

| | | |
|-----------|---|------------|
| 40.12 | Operational Indicator | 346 |
| 40.13 | Local Mode Indicator | 347 |
| 40.14 | External Alarms Indicator | 348 |
| 40.15 | Test Result Indicators (not used) | 349 |
| 40.16 | Reduced Capacity Indicator | 349 |
| 40.17 | AC Power on Indicator | 349 |
| 40.18 | Battery Fault Indicator | 350 |
| 40.19 | Local Mode in Progress | 350 |
| 41 | Installation Data Handling | 353 |
| 41.1 | References | 353 |
| 41.2 | Concepts | 353 |
| 41.3 | General | 353 |
| 41.4 | Database Information Handling Elements | 353 |
| 41.5 | Functions | 355 |
| 41.6 | Operational Conditions | 355 |
| 42 | Self Test and Supervision | 357 |
| 42.1 | References | 357 |
| 42.2 | Concepts | 357 |
| 42.3 | Self Test | 357 |
| 42.4 | Supervision of Memory | 358 |
| 43 | Diagnostics and Fault Handling | 367 |
| 43.1 | References | 367 |
| 43.2 | Concepts | 367 |
| 43.3 | Fault Detection | 368 |
| 43.4 | Fault Localization | 370 |
| 43.5 | Local Action | 371 |
| 43.6 | Fault Reporting | 371 |
| 43.7 | Fault Logging | 372 |
| 43.8 | RBS Diagnostics | 372 |
| 44 | Operation and Maintenance Terminal | 373 |
| 44.1 | References | 373 |

| | | |
|-----------|---|------------|
| 44.2 | Concepts..... | 373 |
| 44.3 | Functions..... | 374 |
| 44.4 | Operational Conditions..... | 382 |
| 45 | External Alarms..... | 383 |
| 45.1 | References..... | 383 |
| 45.2 | Concepts..... | 383 |
| 45.3 | Function..... | 383 |
| 45.4 | Operation and Maintenance..... | 384 |
| 46 | Handling of Auxiliary Equipment..... | 387 |
| 46.1 | References..... | 387 |
| 46.2 | Concepts..... | 387 |
| 46.3 | Function..... | 387 |
| 46.4 | Operational Conditions..... | 388 |
| 47 | Power Supply..... | 389 |
| 47.1 | References..... | 389 |
| 47.2 | Concepts..... | 389 |
| 47.3 | Functions..... | 390 |
| 47.4 | Operational Conditions..... | 390 |
| 48 | Climate Protection..... | 393 |
| 48.1 | Concepts..... | 393 |
| 48.2 | Functions..... | 393 |
| 49 | Transmission Interface Handling G.703 2048 kbit/s..... | 397 |
| 49.1 | References..... | 397 |
| 49.2 | Concepts..... | 397 |
| 49.3 | Functions..... | 399 |
| 49.4 | Operational Conditions..... | 407 |
| 50 | Transmission Interface Handling DS1 1544 kbit/s..... | 409 |
| 50.1 | References..... | 409 |
| 50.2 | Concepts..... | 409 |
| 50.3 | Functions..... | 411 |
| 51 | Terrestrial Link Handling..... | 427 |

| | | |
|-----------|---|------------|
| 51.1 | References..... | 427 |
| 51.2 | Concepts..... | 427 |
| 51.3 | Function..... | 427 |
| 51.4 | Operational Conditions..... | 427 |
| 52 | Channel Distribution Function..... | 429 |
| 52.1 | References..... | 429 |
| 52.2 | Concepts..... | 429 |
| 52.3 | Functions..... | 430 |
| 52.4 | Operational Conditions..... | 438 |
| 53 | Transport Network O&M Functions - DXX Support..... | 441 |
| 53.1 | Introduction..... | 441 |
| 53.2 | References..... | 442 |
| 53.3 | Concepts..... | 443 |
| 53.4 | Functions..... | 444 |
| 53.5 | Operational Conditions..... | 455 |
| 54 | BTS Parameter Limitations..... | 457 |
| 54.1 | Purpose and Readers..... | 457 |
| 54.2 | References..... | 457 |
| 54.3 | Parameters..... | 457 |
| 54.4 | Appendix..... | 464 |
| 55 | Integrated HDSL for RBS 2302, Optional Feature..... | 465 |
| 55.1 | General Description..... | 465 |
| 55.2 | Physical Interface..... | 466 |
| 55.3 | Principle Operating Modes..... | 467 |
| 55.4 | Time Slot Handling in PCM-A and PCM-B..... | 469 |
| 55.5 | Supervision Channel..... | 471 |
| 55.6 | Pre-installation and Commissioning..... | 472 |
| 55.7 | Product Application Information..... | 474 |
| 55.8 | Example A..... | 476 |
| 55.9 | Example B..... | 477 |
| 55.10 | Example C..... | 478 |

| | |
|---------------------------------------|------------|
| 55.11 Example D..... | 479 |
| 55.12 Acronyms and Abbreviations..... | 479 |
| 56 Glossary..... | 481 |

1 Preface

This Reference Manual is valid for the Ericsson GSM system BSS R7.

1.1 Objectives

The manual is intended as an overview of the Ericsson micro and small indoor base stations for the GSM 900 MHz, GSM 1800 MHz and GSM 1900 MHz.

The manual comprises the following:

- Preface (chapter 1)
- RBS 2000 General Information (chapters 2-4)

System Specifications and Requirements

- Supported Configurations (chapters 5-8)

The chapters give an overview of supported site configurations including earthing principles, battery backup times, and so forth, and radio configurations with characteristics and capacity for each configuration.

- Specifications for the base stations and complementary products, including optional features for the base stations (chapters 9-18)

The chapters describe the architecture and specify the characteristics and performance of each product.

- Function Specifications (chapters 19-53)

Provide detailed information about the base stations from a functional point of view. The Function Specifications are customer-adapted and give a deeper understanding of the behavior of the radio base station.

- BTS Parameter Limitations (chapter 54)

State configurable BTS parameters for RBS 2000. BTS parameters with limitations compared with the parameter ranges in the Abis O&M IWD are stated in this chapter.

- HDSL (chapter 55)
- Glossary (chapter 56)

1.2 Audience

Customer and Ericsson personnel involved in radio base station activities.

1.3 MAXITETM Trademark

MAXITETM is a trademark owned by Telefonaktiebolaget L M Ericsson, Sweden.

1.4 Customer Documentation Library

The user documentation for RBS 2301, RBS 2302, RBS 2401 and MAXITE™ consists of customer manuals and procedures, divided to suit different process events. The *Library Overview* contains the following information for each manual:

- Short description
- Recommendation of appropriate target group
- Product number

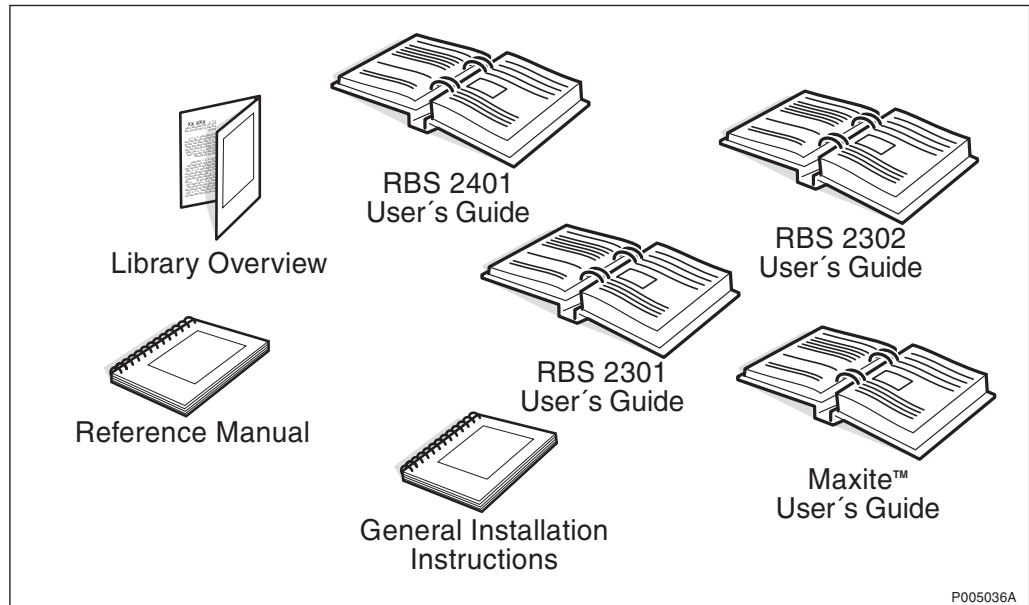

Figure 1 The Customer documentation library

1.5 Release History

Except editorial changes such as correction of spelling, grammar and layout, this manual has been revised as follows.

1.5.1 R6A to P6B

Table 1

| Chapter | Chapter Heading | Revised Sections and Sub-Sections | Description |
|---------|--|--------------------------------------|--|
| | Contents | | The manual structure has been changed to match that of the Macro manual. |
| 1 | Preface | 1.5.1 | Release History for R5A to R6A deleted and exchanged for R6A to P6B. |
| 2 | Site Configurations, RBS 2000 Micro | 2.4.1 | Configuration 2 RBS and 1 PBC has been included. |
| 4 | Radio Configurations, RBS 2000 Micro | 4.5.7 4.8 and 4.9 | Configurations M9d_2.2\C, M9d_4.4\C, M9d_6.6\C and M9d_2.2H have been added in Table 7. New sections with the above mentioned configurations. |
| 8 | Product Specification for RBS 2401 | 8.2 8.8.5 | The operating temperature has been changed to +5 °C to +40 °C. The operating temperature has been changed to +5 °C to +40 °C. |
| 9 | Product Specification for Power and Battery Cabinet | 9.7.1 9.7.2 | Cable attenuation value 0-9 for GSM 900 MHz has been added. AC/DC fault: Output voltage has been changed from less than 45 V to less than 41.5 V. |
| 10 | Product Specification for 500 W Active Antenna Unit | | Link Interruption has been removed. |
| 11 | Product Specification for 1250 W Active Antenna Unit | | Link Interruption has been removed. |
| 12 | Product Specification for Coverage Extension Unit | 12.3.4 12.3.4 12.3.4 12.3.4 | Alarm description: > 6 dB loss has been changed to < 6 dB. Link Interruption has been removed. Environment: The operating temperature has been changed from +45 °C to +55 °C. Site Installation: The minimum separation side by side and back to back has been changed from 1 m to 0.2 m. |
| 27 | Synchronization | | Updated. |
| 38 | Operation and Maintenance Terminal | | DXU+ added. |
| 46 | Environmental Capabilities | 46.7 46.8 | The operating temperature has been changed to -33 °C - +55 °C. The operating temperature has been changed to +5 °C to +40 °C. |

Note: Chapters not listed in the table are unchanged.

1.5.2 PB6 to R7A*Table 2*

| Chapter | Chapter Heading | Revised Sections and Sub-Sections | Description |
|-------------------|--|--|--|
| 1, 13, 14, 15, 49 | | | CME 20 has been changed to the Ericsson GSM system. |
| 1 | Preface | 1.5.1 | Release History for R5A to R6A deleted and exchanged for P6B to R7A. |
| 5 | Site Configurations, RBS 2000 Micro | 5.1 5.3.1 5.4.1 | CEU has been included in Terminology. Booster has been changed to CEU in Table 13. The one-way connection between AAU and PBC (Data DC -48 V) has been removed. |
| 7 | Radio Configurations, RBS 2000 Micro | 7.1 7.2.4 7.5.7 | Version 4.13.0 has been changed to 'latest version'. Coverage Extension Unit has been added. GSM 900 2x2 and 3x2 configurations have been added into Table 17. |
| 10 | Product Specification for RBS 2302 | 10.1 | MAXITE™ has been rewritten according to Chapter 15. |
| 13 | Product Specification for 500 W Active Antenna Unit | 13.1 13.2, 13.3.1, 13.3.3, 13.4.3, 13.4.4 | MAXITE™ has been rewritten according to Chapter 15. Minor changes and corrections have been made. |
| 14 | Product Specification for 1250 W Active Antenna Unit | 14.1 | MAXITE™ has been rewritten according to Chapter 15. |
| 15 | Product Specification for Coverage Extension Unit | 15.3.4 15.3.4 15.3.4 | Uplink MS Output Power has been changed to 33 dBm EIRP, and Path Loss to 162.5 dB. Maximum power consumption has been changed to 240 W. 'JTC standard FCC rules and regulations' has been deleted in Type Approval Standard. |

Note: Chapters not listed in the table are unchanged.

2 Product Safety Requirements RBS 2000

This chapter specifies the product safety requirements for RBS 2000.

2.1 References

| | |
|---------------------|--|
| IEC 215 | Safety requirements for radio transmitting equipment. |
| EN 60950 | Safety of Information Technology Equipment. Including Electrical Business Equipment. |
| IEC 950 | Safety of Information Technology Equipment. Including Electrical Business Equipment. |
| CAN/CSA-C22.2 | No 1-M94 Audio, Video and Similar Electronic Equipment. |
| CAN/CSA-C22.2 | No 950-95 Safety of Information Technology Equipment Including Electrical Business Equipment. |
| UL 1419 | Standard for Professional Video and Audio Equipment. |
| 73/23/EEC | Low Voltage Directive. |
| UL 1950 3rd edition | Safety of Information Technology Equipment Including Electrical Business Equipment. |
| IEC 529 | Classification of degrees of protection provided by enclosures. (IP Code). |

2.2 Product Safety

This section defines the Electrical, Mechanical, Heat and Fire Safety Requirements for the Radio Base Station. The RBS is designed to fulfil the following International Standards:

73/23/EEC Low Voltage Directive. (To achieve this, the RBS conforms to the standards below).

EN 60 950 "Safety of Information Technology Equipment Including Electrical Business Equipment".

This means that we comply with the general IEC 950 including national differences notified in EN 60 950.

IEC 215 Safety requirements for transmitting equipment.

The product shall be listed by National Recognized Testing Laboratory (NRTL).

For the US the following standards are applicable:

UL 1950 3rd edition "Safety of Information Technology Equipment Including Electrical Business Equipment".

UL 1419 Standard for Professional Audio and Video Equipment.

For Canada the following standards are applicable:

CAN/CSA-C22.2 No 1-M94 Audio, Video and Similar Electronic Equipment.

CAN/CSA-C22.2 No 950-95 Safety of information technology including electrical business equipment.

General

The RBS fulfills encapsulation class IP 55. Additional to this the product fulfils the environmental requirements.

According to: IEC 529.

This document gives the requirement for the RBS to fulfill the general safety requirements as follows:

The RBS is so designed and constructed that, under all conditions of normal use and under a likely fault condition, it protects against personal injury from electrical shock and other hazards. The RBS is also protecting against serious fire originating in the equipment, mechanical hazards in the equipment, as well as mechanical hazards in the meaning of the applicable standard.

The RBS is connected directly to the Telecommunication network; hence the equipment must be provided with adequate protection, as specified in IEC 950 and UL 1950 3rd edition.

- Protection to ensure compliance with the requirements for TNV circuits, and protection against electric shock.
- Protection for the Service Personnel and other users of the Telecommunication Network from hazards in the equipment.
- Protection for the equipment users from voltages on the Telecommunication Network.
- Protection against overvoltage. (Only applicable for UL 1950 3rd edition.)

2.2.1 Declaration of Conformity

Tests and inspections are carried out according to ECMA requirements.

3 Building Practice Requirements RBS 2000

This chapter specifies the building practice requirements for RBS 2000.

3.1 Fire Resistance

The fire resistance of assemblies for Ericsson equipment are based on the properties of the materials, components and cables which are used for the construction of these assemblies. The properties concerning fire resistance are measured according to widely accepted national and international standards.

Fulfilled standards

For Europe the following standard is met:

EN 60 950 Safety of Information Technology (IEC 950).

For US the following standards is met:

UL 1950 third edition."Safety of Information Technology Equipment Including Electrical Business Equipment".

For Canada the following standard is met:

CAN/CSA-C22.2 No 950 Safety of information technology including electrical business Eq.

3.1.1 Criteria for fire resistance of wire and cables

For Europe the following standard are used:

IEC standard 332, Part 1.

IEC standard 332, Part 3 Category C.

For the US and Canada the following standards are used:

UL 1581, section 1160

UL 1685, Fire-propagation and Smoke-release

CAN/CSA-C22.2 No 03.

3.1.2 Criteria for fire resistance of components.

IEC Standard 695-2-2, Fire Hazard Testing, part 2 Test Methods - Needle Flame Test, with application times according to the table below:

Table 3 Fire resistance of components

| Components volume (mm ³) | Application time (s) |
|--------------------------------------|----------------------|
| <250 | 5 |
| 250 - 500 | 10 |
| 500 - 1750 | 20 |
| > 1750 | 30 |

Required test result:

The afterburning time for a component may not exceed 15 s. No burning or glowing particles may fall from specimen.

3.1.3 Criteria for flame resistance of materials

ASTM Standard D 2863-77, Oxygen Index (OI)

Required Test result: OI \geq 28

or

UL Standard 94 Vertical Burning Test for Classifying Materials.

Requirements according to specification in:

IEC 950, UL 1950, CSA C22.2 No. 950.

3.2 Poisonous Fumes

Apart from the inevitable carbon monoxide fumes and the possible HCl (Hydrochloric acid) fumes there will be no other noxious, corrosive or poisonous fumes in any harmful concentration during fire in Ericsson equipment.

3.3 Declaration of Materials

Materials which are under legal restrictions are declared according to relevant standards.

3.4 Silicone

The use of silicone products is restricted to the use of wiremesh silicone rubber gasket for enclosures of Ericsson equipment cabinets. The wiremesh is applied as EMC protection.

3.5 Environmental Consideration during the Life-Cycle

According to "US Clean air act" Amendment Sect. 611. Label requirements for Ozone-depleting substances, all products that are manufactured using and containing the substance listed below shall be marked in accordance to previous mentioned law. Products with subunits manufactured using the substance below do not have to be marked on higher level than subunit level.

Substance which Clean Air Act is applicable for:

CFC-11, CFC-12, CFC-13, CFC-111, CFC-112, CFC-113, CFC-114, CFC-115, CFC-211, CFC-212, CFC-213, CFC-214, CFC-215, CFC-216, CFC-217, Halon-1211, Halon-1301, Halon-2402, Carbon tetrachloride (CT), Methyl- chloroform (1, 1, 1 - trichloroethane).

4 Environmental Capabilities

The purpose of this chapter is to specify the environmental capabilities for RBS 2301, RBS 2302, RBS 2401, Coverage Extension Unit and Active Antenna Unit.

4.1 Scope

This chapter describes the environmental capabilities for the indoor and outdoor temperature non-controlled operation conditions. Subjects included are: Climatic, Biological, and Chemically active substances; Mechanically active substances, and Mechanical conditions.

The capabilities cover the base station excluding installation and adjacent parts as antenna and earth connectors.

Note: The names of the various climate classes in the following section are for classification purpose only and are not intended to limit the use of the products.

4.2 Terminology

Definition of concepts:

Normal Operation Conditions

Environmental conditions where all units shall be able to function as specified.

Safe Function

Environmental stress above the limits for normal operation where all units shall continue to function during the stress, but performance or capacity may be reduced.

Reduction of performance or capacity shall be documented as typical value.

When the environmental stress has dropped to normal operation conditions, function as specified shall automatically be achieved.

Safe function refers to an operation period of not more than 72 consecutive hours, and a total of not more than 15 days in one year.

Non-Destruction

Environmental stress above the limits for safe function during which no function is guaranteed and performance may degrade in an unspecified manner.

When the environmental stress has dropped to normal operation conditions, no manual intervention (on site) is needed to restore full performance of the RBS.

Non-destruction refers to an operation period of not more than 96 consecutive hours, and a total of not more than 5.5 days in a 3-year period.

GSM Concepts

The GSM concepts for Normal operation and Extreme operation conditions as defined in GSM 11.20-12.3.2 are both equal to the Normal condition as defined and used in this document. This means that all RF parameters are guaranteed within the Normal condition range as defined in this document.

4.3 References

| | |
|-------------------|--|
| IEC 721-3-.. | Classification of groups of environmental parameters and their severities. |
| ETSI 300 019-1-.. | Classification of environmental conditions. |
| ETSI 300 019-2-.. | Environmental conditions and environmental tests for telecommunications equipment. |

4.4 Transport -40 °C - +70 °C

4.4.1 General Conditions

The severity of the requirements is in conformity with: IEC 721-3-2 classes 2K4/2B2/2C2/2S2/2M2. and ETS 300 019-1-2 Class 2.3 "PUBLIC transportation".

These requirements are valid for equipped cabinets (excluding batteries). The values in these conditions are valid for a maximum transport time of 3 months. The time is measured from the moment the packages leave the shipping store, and includes storing in connection with the transport.

Note: These requirements restrict flight transportation to aircraft with pressure cabins. As modern aircraft have pressure cabins, these limitations are expected to be only formal.

4.4.2 Climatic Conditions

During transportation the equipment could be exposed to extremes in temperature and humidity. The equipment shall be in packaged condition.

Table 4

| Environmental Parameters | Unit | Value |
|--------------------------|------|-----------|
| Temperature | °C | - 40- +70 |
| Relative Humidity | % | 5-100 |

4.4.3 Biological Conditions

The severity of these requirements is in conformity with:

- IEC 721-3-2 class 2B2
- ETS 300 019-1-2 Class 2.3

4.4.4 Chemically Active Substances

The severity of these requirements is in conformity with:

- IEC 721-3-2 class 2C2
- ETS 300 019-1-2 Class 2.3

4.4.5 Mechanically Active Substances

The severity of these requirements is in conformity with:

- IEC 721-3-2 class 2S2
- ETS 300 019-1-2 Class 2.3

4.4.6 Mechanical Conditions

The packing and transport method is chosen in order not to expose the equipment to stress beyond these limits.

The severity of these requirements is in conformity with:

- IEC 721-3-2 class 2M2
- ETS 300 019-1-2 Class 2.3

Requirements

Table 5

| Environmental Parameters | Unit | Value | |
|--------------------------|--------------------------------|-------|------------------|
| Vibration sinus: | | | |
| displacement | mm | 3.5 | |
| acceleration | m/s ² | 10 | 15 |
| frequency | Hz | 2-9 | 9-200 200-500 |
| Random ASD: | m ² /s ³ | 1.0 | |
| acceleration | m/s ² | 12.0 | |
| frequency | Hz | 2-200 | |
| Shock: | | | |
| peak acceleration | m/s ² | 100 | |
| duration | ms | 11 | |

4.5 Storage -25 °C - +55 °C

4.5.1 General Conditions

The severity of the requirements is in conformity with: IEC 721-3-1 classes 1K4/1Z2/1Z3/1Z5/1B2/1C2/1S3/1M2, and ETS 300 019-1-1 Class 1.2. "WEATHERPROTECTED, not temperature-controlled storage".

During storage the equipment shall be packaged. The values in these conditions are valid for a maximum storage time of 12 months. The time refers to equipment in its outer package and stored at the consignee in a conditioned store.

4.5.2 Climatic Conditions

The equipment shall be in packaged condition.

The severity of these requirements is in conformity with:

- IEC 721-3-1 classes 1K4/1Z2/1Z3/1Z5
- ETS 300 019-1-1 Class 1.2

Requirements

Table 6

| Environmental Parameters | Unit | Value |
|--------------------------|------|------------|
| Temperature | °C | - 25 - +55 |
| Relative Humidity | % | 10 -100 |

4.5.3 Biological Conditions

The severity of these requirements is in conformity with:

- IEC 721-3-1 class 1B2
- ETS 300 019-1-1 class 1.2

4.5.4 Chemically Active Substances

The chemically active substances are according to:

- IEC 721-3-1 class 1C2
- ETS 300 019-1-1 class 1.2

Note: The values are average yearly levels of airborne contaminants that can be accepted. It is assumed that one of the contaminants is dominant at each site, and that the others are present in insignificant amounts.

4.5.5 Mechanically Active Substances

The severity of these requirements is in conformity with:

- IEC 721-3-1 class 1S3
- ETS 300 019-1-1 Class 1.2

4.5.6 Mechanical Conditions

The packing and transport method shall be chosen in order not to expose the equipment to stress beyond these limits.

The severity of these requirements is in conformity with:

- IEC 721-3-1 class 1M2
- ETS 300 019-1-1 Class 1.2

In addition to this, Ericsson demands more rigorous values than stated by IEC and ETSI above.

Requirements

Table 7

| Environmental Parameters | Unit | Value |
|--------------------------|------------------|-----------------|
| Vibration sinus: | | |
| Displacement | mm | 3.5 |
| Acceleration | m/s ² | 10 |
| Frequency | Hz | 2-9 9 -200 |
| Shock: | | |
| Peak acceleration | m/s ² | 40 |
| Duration | ms | 22 |

4.6 Handling -40 °C - +70 °C

4.6.1 General Conditions

This section refers to shorter periods of transport and storage in unpacked conditions. Precautions to avoid condensation before subjecting the equipment to operational conditions are necessary.

4.6.2 Climatic Conditions

During handling the equipment withstands the conditions stated in Section 4.4.2 on page 24 in this document.

4.6.3 Biological Conditions

During Handling the equipment withstands the conditions stated in Section 4.4.3 on page 24 in this document.

4.6.4 Chemically Active Substances

During Handling the equipment withstands the conditions stated in Section 4.4.4 on page 25 in this document.

4.6.5 Mechanically Active Substances

During Handling the equipment withstands the conditions stated in Section 4.4.5 on page 25 in this document.

4.6.6 Mechanical Conditions

The equipment shall endure stresses normal for handling. During handling the equipment withstands the conditions stated in Section 4.4.6 on page 25 in this document.

4.7 Operation Mast Mounted Equipment -33 °C - +55 °C

4.7.1 General Conditions

General conditions conform to:

- IEC 721-3-4 classes 4K2/4Z5/4Z7/4B1/4C2(4C3)/4S2/4M5

- ETS 300 019-1-4 class 4.1 NON-WEATHER PROTECTED Location
- Additional requirements for mast mounted equipment are included.

Note: The temperature range is extended to +45 °C.

This clause refers to the environment which an RBS for outdoor non-weather protected location shall endure. The equipment must in all situations fulfil legal requirements and not become hazardous to people.

The tables below refer to the environment that surrounds the cabinet and the temperature is the shaded ambient air temperature.

4.7.2 Climatic Conditions

The climatic conditions conform to:

- IEC 721-3-4 classes 4K2/4Z5/4Z7
- ETS 300 019-1-4 class 4.1

In addition to this, Ericsson demands more rigorous values than stated by IEC and ETSI above.

Table 8 Climatic conditions during outdoor operation

| Environmental Parameters | Value | |
|--------------------------|------------------|-----------------|
| | Normal Condition | Non-Destructive |
| Temperature, °C | -33 - +45 | -40 - +70 |
| Relative humidity, % | 15 - 100 | 15 - 100 |

4.7.3 Biological Conditions

The biological conditions conform to:

- IEC 721-3-4 class /4B1/
- ETS 300 019-1-4 class 4.1

4.7.4 Chemically Active Substances

The chemically active substances conform to:

- IEC 721-3-4 classes /4C2(4C1)/
- ETS 300 019-1-4 class 4.1

Note: The values of these capabilities are average yearly levels of airborne contaminants that can be accepted. It is assumed that one of the contaminants is dominant at each site, and that the others are present in insignificant amounts.

4.7.5 Mechanically Active Substances

The mechanically active substances conform to:

- IEC 721-3-4 class /4S2/
- ETS 300 019-1-4 class 4.1

4.7.6 Mechanical Conditions

The mechanical conditions conform to:

- IEC 721-3-4 class /4M5/
- ETS 300 019-1-4 class 4.1

In addition to this, Ericsson demands more rigorous values than stated by IEC and ETSI above.

Table 9 Mechanical conditions during operation outdoor

| Environmental Parameter | | Value |
|-------------------------|------------------------------------|------------------------------------|
| Vibration sinusoidal | displacement, mm | 3.0 |
| | acceleration, m/s^2 | 10 |
| | frequency, Hz | 2 - 9 9 - 200 |
| Vibration random | ASD ¹⁾ , m^2/s^3 | 0.5 |
| | frequency, Hz | 2 - 200 |
| | Duration of exposure, min | 30 |
| | no. of test directions | 3 |
| Shock | peak acceleration, <100 kg m/s^2 | 250 |
| | peak acceleration, >100 kg m/s^2 | 100 ²⁾ |
| | duration, ms | 6 |

¹⁾ ASD = Acceleration Spectral Density

²⁾ The requirement belongs to safe function with the following exception: Performance of the RBS shall be verified as "no loss of calls".

4.7.7 Seismic Exposure

Table 10 Safe function during seismic exposure

| | |
|----------------------------|----------------------------------|
| Testing Severity | |
| Frequency range | 1-15 Hz |
| Required Response Spectrum | RRS (Required Response Spectrum) |
| Shape of RRS | as IEC 68-2-57 fig. 3 |

4.8 Operation Indoor +5 °C - +40 °C

4.8.1 General Conditions

The general conditions conform to:

- IEC 721-3-3 classes 3K3/3Z2/3Z4/3B1/3C2(3C1)/3S2/3M1
- ETS 300 019-1-3 Class 3.1 Temperature controlled locations

4.8.2 Climatic Conditions

The climatic conditions conform to:

- IEC 721-3-3 classes 3K3/3Z2/3Z4
- ETS 300 019-1-3 Class 3.1

4.8.3 Biological Conditions

Not applicable.

4.8.4 Chemically Active Substances

The chemically active substances conform to:

- IEC 721-3-3 classes /3C2/3C1/
- ETS 300 019-1-3 Class 3.1

Note: The values are average yearly levels of airborne contaminants that can be accepted. It is assumed that one of the contaminants is dominant at each site, and that the others are present in insignificant amounts.

4.8.5 Mechanically Active Substances

The mechanically active substances conform to:

- IEC 721-3-3 class /3S2/
- ETS 300 019-1-3 Class 3.1

4.8.6 Mechanical Conditions

The mechanical conditions conform to:

- IEC 721-3-3 class /3M1/
- ETS 300 019-1-3 Class 3.1

Table 11 Mechanical conditions during operation indoor

| Environmental Parameters | Unit | Value |
|--------------------------|--------------------------------|------------|
| Vibration sinus: | | |
| Displacement | Mm | 0.6 |
| Acceleration | m/s ² | 2 |
| Frequency | Hz | 2-9 9 -200 |
| Vibration random: | | |
| ASD | m ² /s ³ | 0.1 Note 1 |
| ASD | m ² /s ³ | 0.2 Note 2 |
| Acceleration | m/s ² | 3.8 Note 1 |
| Acceleration | m/s ² | 5.4 Note 2 |
| Frequency | Hz | 2 - 200 |
| Shock: | | |
| Peak acceleration | m/s ² | 40 Note 3 |
| Duration | ms | 22 |

Note 1: Safe function

Note 2: Non-destruction

Note 3: The requirement belongs to "Safe function" with the exception: performance shall be verified as "no loss of calls".

4.8.7 Seismic Exposure

Table 12 Safe function during seismic exposure

| Testing Severity | |
|----------------------------|----------------------------------|
| Frequency range | 1-15 Hz |
| Required Response Spectrum | RRS (Required Response Spectrum) |
| Shape of RRS | as IEC 68-2-57 fig. 3 |

This page is intentionally left blank

5 Site Configurations, RBS 2000 Micro

5.1 Terminology

| | |
|--------------------|---|
| AAU | Active Antenna Unit The AAU is designed in three versions; 500 W for GSM 1800, 500 W and 1250 W for GSM 1900. |
| AC box | The AC box splits the incoming mains to the site to different AC users in the site. This is external equipment that is delivered by the local support organization in each country or region. |
| ALPU | Antenna Lightning Protection Unit The ALPU is an optional box that protects the Active Antenna from lightning strikes. |
| CEU | Coverage Extension Unit for GSM 900 |
| HISC | Highway Splitter Combiner |
| Interfaces | There are a number of interfaces in the system: AC mains, DC 24 V, DC -48 V, External alarms, Alarms, Data, Transmission, T,X,L-bus, RF Feeders |
| N/A | Not Applicable |
| Mini Link E-micro | Mini Link E-micro is a transmission unit that sends transmission via the radio interface. |
| MLPU | Mini Link Lightning Protection Unit |
| PBC | Power Battery Cabinet The PBC converts AC mains to 24 V and -48 V. It includes battery backup for RBS and AAU. |
| R1P1A1RL1PL1AL1/M1 | Configuration with: 1 RBS, 1 PBC, 1 AAU, 1 RLPU, 1 PLPU, 1 ALPU and optional 1 Mini Link |
| RBS 2302 | RBS 2302 is a radiobasestation based on the RBS 2301. It is developed for 6 TRX functionality and prepared for MAXITE™ installations. |

t_{ext} means External temperature.

5.2 System Overview

Note: 4 TRX and 6 TRX are only valid for R7 and later.

5.2.1 Site Configurations Overview

The tables below describe the different site configurations for RBS 2302 products.

Fan units and Mini Link configurations are considered to be optional and therefore marked with a "slash" (/), for example "/RF1" or "/M1").

Table 13 RBS 2302 Site Configurations

| Short No. | Slogan | RBS 2302 | P B C | A A U | HI SC | Ant./ Feeder Lightn. Prot. | Fan Unit | Mini Link |
|-------------------------|---|----------|-------|-------|-------|----------------------------|----------|-----------|
| | | (R) | (P) | (A) | (H) | (AL) | (RF, PF) | (M) |
| R1 | 2 TRX | 1 | | | | | /RF1 | |
| R2 | 4 TRX | 2 | | | | | /RF2 | |
| R3 | 6 TRX | 3 | | | | | /RF3 | |
| R1P1 | 2 TRX external backup | 1 | 1 | | | | /RF1 | /M1 |
| R2P2 | 4 TRX external backup | 2 | 2 | | | | /RF2 | /M1 |
| R3P3 | 6 TRX external backup | 3 | 3 | | | | /RF3 | /M1 |
| R1P1A1 | Maxite Basic 2 TRX | 1 | 1 | 1 | | | | /M1 |
| R2P2A2 | Maxite Basic 4 TRX | 2 | 2 | 2 | | | | /M1 |
| R3P3A3 | Maxite Basic 6 TRX | 3 | 3 | 3 | | | | /M1 |
| R1P1A1 RL1PL1 AL1 | Maxite Basic 2 TRX Lightn. Protect. | 1 | 1 | 1 | | 1 | | /M1 |
| R2P2A2 RL2PL2 AL2 | Maxite Basic 4 TRX Lightn. Protect. | 2 | 2 | 2 | | 2 | | /M1 |
| R3P3A3 RL3PL3 AL3 | Maxite Basic 6 TRX Lightn. Protect. | 3 | 3 | 3 | | 3 | | /M1 |

| | | | | | | | | |
|---------------------------|---|---|---|---|---|---|--|-----|
| R1P2A2 H2 | Maxite Highway 2 TRX | 1 | 2 | 2 | 2 | 1 | | /M1 |
| R1P2C2 H2RL1 PL2CL2 | Maxite Highway 2 TRX Lightn. Protect. | 1 | 2 | | 2 | 1 | | /M1 |

Note: Not all configurations are described with a figure.

5.2.2 Grounding of MAXITE™ Configurations

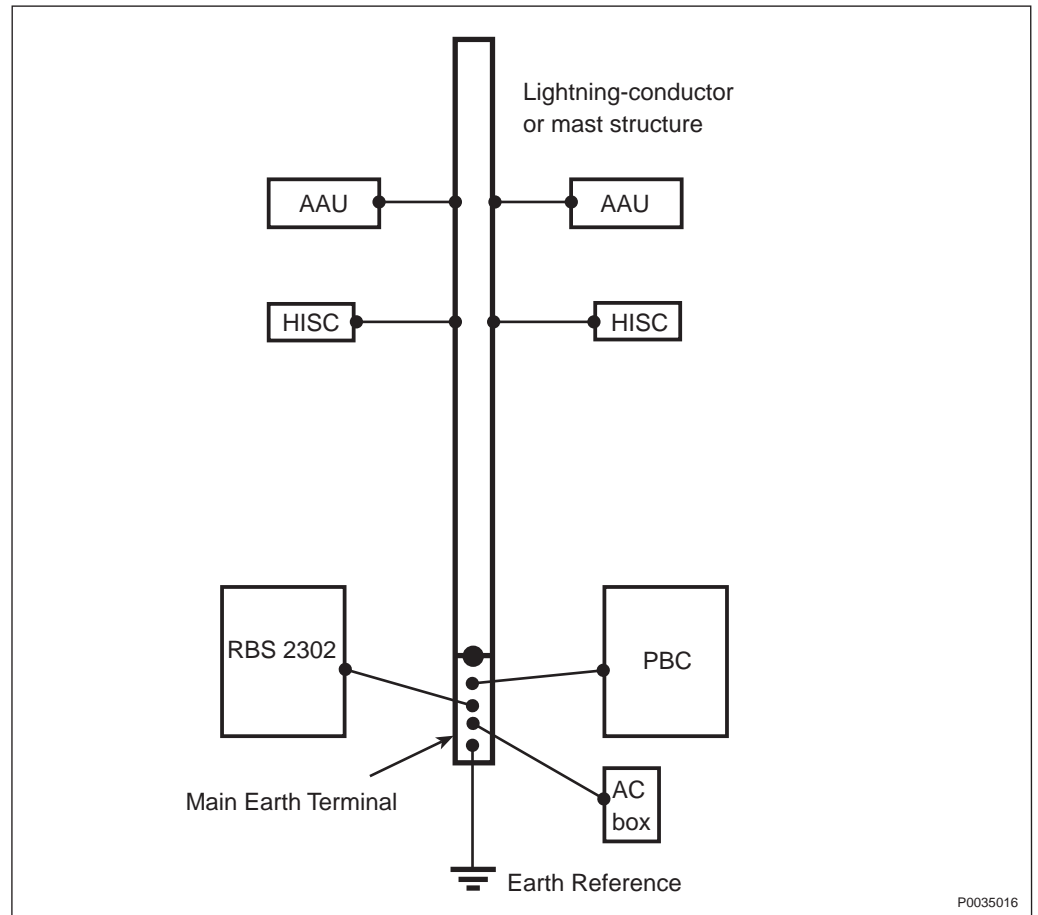

Figure 2 Grounding without optional Lightning Protection

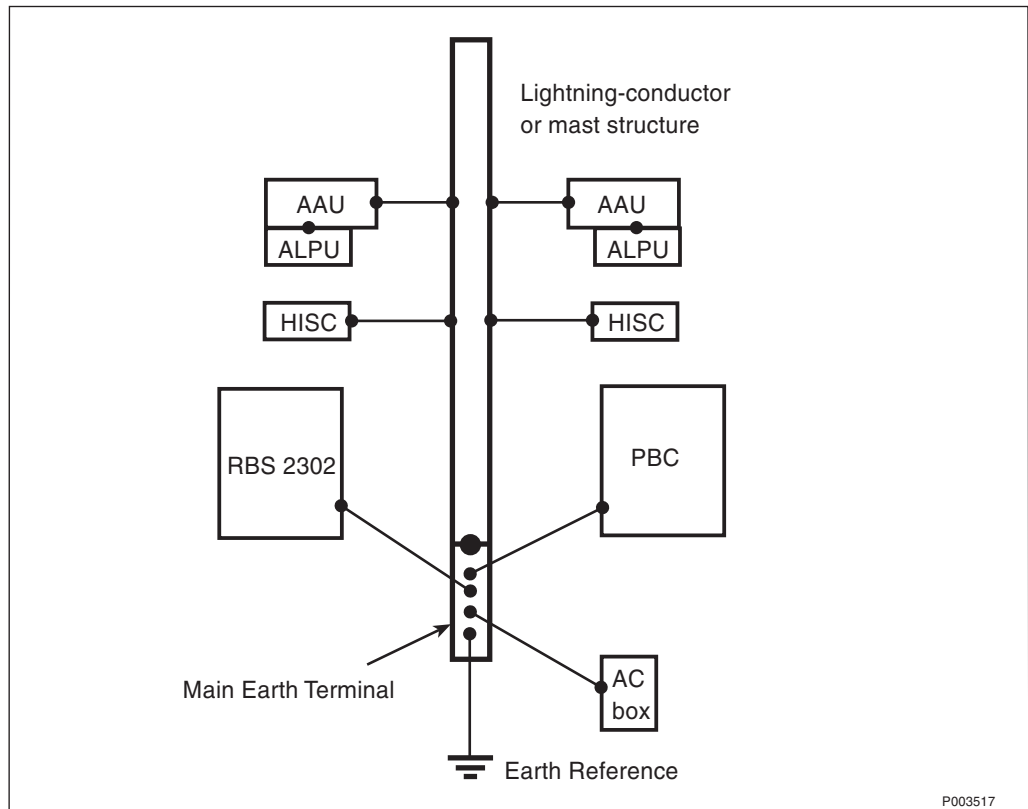

Figure 3 Grounding with optional Lightning Protection

Mechanical Grounding

Mechanical Grounding is required between:

- AAU and ALPU

Bonding Strap

Bonding Strap is required between:

- AAU and lightning conductor/mast structure
- PBC and lightning conductor/mast structure
- RBS and lightning conductor/mast structure
- HISC and lightning conductor/mast structure
- AC box and lightning conductor/mast structure
- PBC

Mechanical Grounding, Bolt

Mechanical Grounding, Bolt is optional between:

- AAU to lightning conductor/mast structure
- PBC and lightning conductor/mast structure
- RBS and lightning conductor/mast structure

Bonding Strap Dimension

Required dimension: 16 mm²
 Optional dimension: 24 mm²

Feeders and Antenna DC/Data

Feeders and antenna cables must be grounded on half the length if they are 30 to 60 meters long. An extra grounding point is required for every 30 metres length added to the feeder length.

The distance between an end point and a grounding point, or two grounding points is not allowed to be more than 30 metres.

Note: Feeders and antenna cables do not have to be grounded in the connection point to the AAU since the AAU is bolted to the lightning conductor or mast structure.

Note: Feeders do not have to be grounded in the connection point to the RBS 2302, if the RBS 2302 is bolted to the lightning conductor or mast structure.

Note: Feeders must be grounded where it leaves the lightning conductor or mast structure, if the RBS 2302 is not mounted on a mast structure.

5.3 Power Consumption

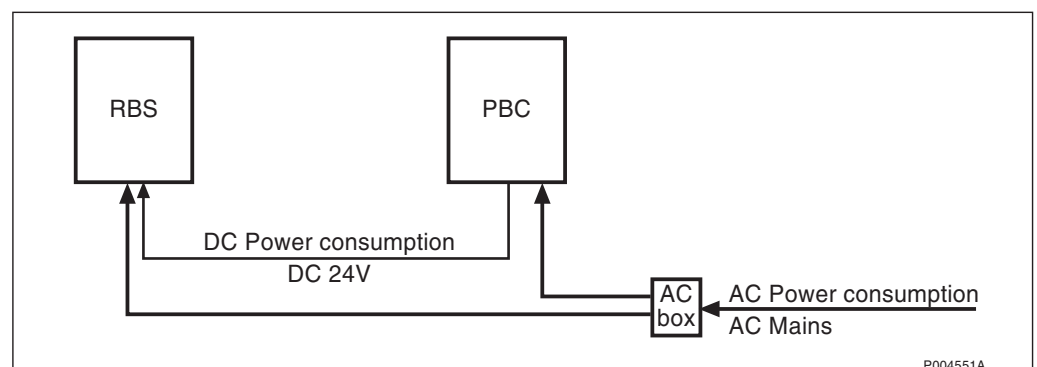

Figure 4 Power consumption – definition

5.3.1 General

AC/DC loss

- Calculated with an RBS PSU efficiency of 81 % on the AC/DC converter, and a PBC PSU efficiency of 83 %.

Back-up time

- The back-up time is measured on one configuration. The result of the measurement is used to calculate the theoretical back-up time for all other configurations.

DC/DC loss

- Calculated with a PBC PSU efficiency of 84 %.

Cable loss

- Calculated for 100 m cable.

Maximum power consumption

- The heater is active in AC mode, trickle charge 10 W, $t_{ext} < -20$ °C. The heater is not on when in battery back-up mode.

Nominal power consumption

- Based on nominal operation conditions. That is, the heater is off, trickle charge 10 W, $t_{ext} = 20$ °C. Both transceivers are sending with full output power at 230 V nominal mains supply.

Trickle charge

- Charge of PBC during operation in AC mode.

Table 14 Power consumption – product

| Product | AC Power Mode | | Battery Back-Up Mode | |
|------------------------------------|------------------------|---------------------------|------------------------|---------------------------|
| | Max. Power Consumption | Nominal Power Consumption | Max. Power Consumption | Nominal Power Consumption |
| AAU 500 W | 240 W | 180 W | 240 W | 180 W |
| AAU 1250 W | 280 W | 210 W | 280 W | 210 W |
| ALPU | 10 W | 10 W | 10 W | 10 W |
| CEU | 240 W | 155 W | 240 W | 155 W |
| Cable Loss to Antenna, 100 m cable | 31 W | 18 W | 31 W | 18 W |
| Heater, RBS | 350 W | 0 | 0 | 0 |
| RBS 2302 | 90 W | 75 W | 85 W* | 71 W * |
| Mini Link | 35 W | 30 W | 35 W | 30 W |
| Cable Loss to Mini Link | 1 W | 1 W | 1 W | 1 W |
| DC/DC Loss | N/A | N/A | 16 % | 16 % |
| AC/DC Loss RBS | 21 % | 21 % | N/A | N/A |
| AC/DC Loss PBC | 17 % | 17 % | N/A | N/A |
| Heater, PBC | 36 W | 0 | 0 | 0 |

* Calculated values

The power consumption is not dependent on DC/DC loss in AC Power Mode because the power consumption in back-up mode is defined as the consumption seen from the PBC.

The back-up time is dependent on DC/DC loss.

The table below shows the power consumption and the back-up time for configurations with RBS 2302.

Table 15 Power consumption – back-up time

| Short No. | Slogan | Nominal Power Consumption AC Mode | Maximum Power Consumption AC Mode | Nominal Power Consumption DC Mode | Maximum Power Consumption DC Mode | Battery Back-Up Time |
|-------------|-----------------------------------|-----------------------------------|-----------------------------------|-----------------------------------|-----------------------------------|----------------------|
| R1 | 2 TRX | 75 W | 440 W | 70 W | 85 W | 16 min |
| R2 | 4 TRX | 150 W | 880 W | 140 W | 170 W | 16 min |
| R3 | 6 TRX | 225 W | 1320 W | 215 W | 255 W | 16 min |
| R1P1 | 2 TRX ext. backup | 85 W | 485 W | 70 W | 85 W | 6 h |
| R2P2 | 4 TRX extra ext. backup | 170 W | 970 W | 140 W | 170 W | 6 h |
| R3P3 | 6 TRX ext. backup | 255 W | 1460 W | 215 W | 255 W | 6 h |
| R1P1A1 | Maxite Basic 2 TRX | 325 W | 815 W | 270 W | 355 W | 1.5 h |
| R2P2A2 | Maxite Basic 4 TRX | 650 W | 1630 W | 540 W | 710 W | 1.5 h |
| R3P3A3 | Maxite Basic 6 TRX | 975 W | 2445 W | 805 W | 1070 W | 1.5 h |
| R1P1A1AL1 | Maxite Basic 2 TRX Light. Prot. | 335 W | 825 W | 280 W | 365 W | 1.5 h |
| R2P2A2AL2 | Maxite Basic 4 TRX Light. Prot. | 660 W | 1640 W | 550 W | 720 W | 1.5 h |
| R3P3A3AL3 | Maxite Basic 6 TRX Light. Prot. | 985 W | 2455 W | 815 W | 1080 W | 1.5 h |
| R1P2A2H1 | Basic Highway 2 TRX Light. Prot. | 575 W | 1190 W | 470 W | 625 W | 1.5 h |
| R1P2A2H1AL2 | Maxite Highway 2 TRX Light. Prot. | 585 W | 1200 W | 480 W | 635 W | 1.5 h |

5.4 Configuration

5.4.1 Site Configurations

RBS 2302 Configurations

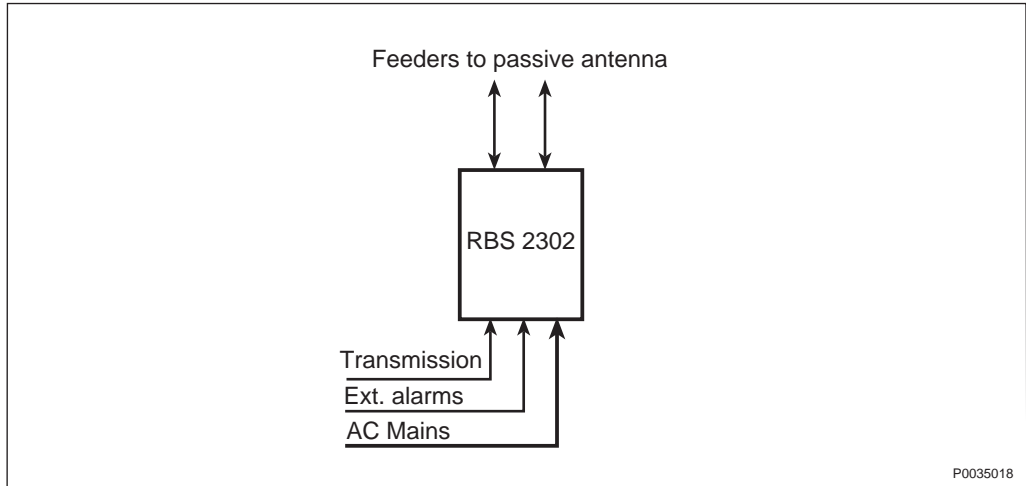

Figure 5 2 TRX (R1)

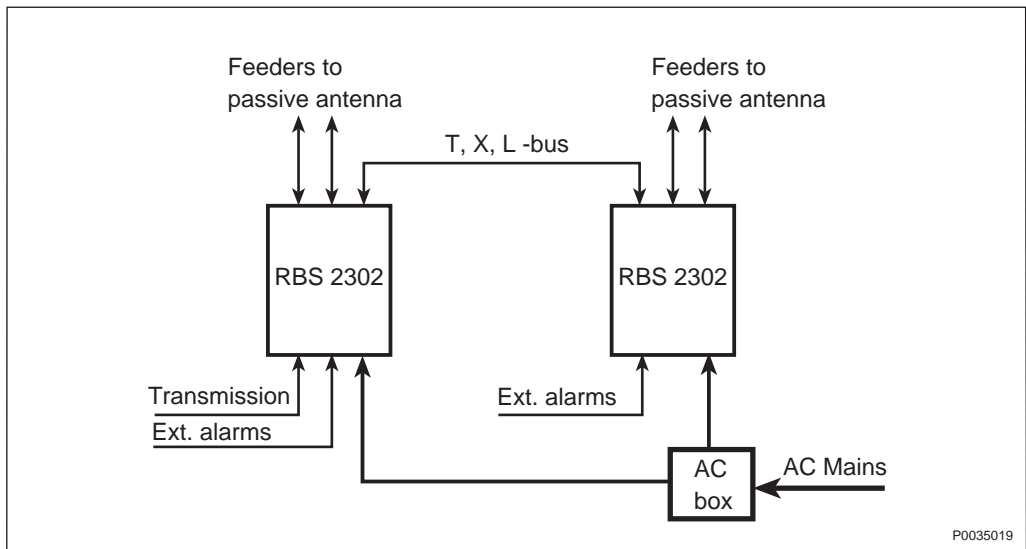

Figure 6 4 TRX (R2)

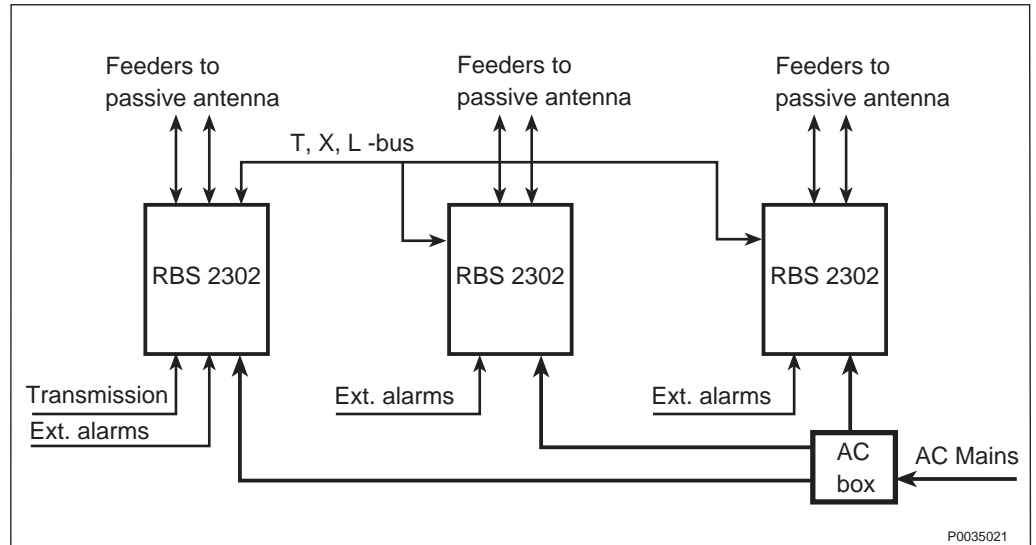

Figure 7 6 TRX (R3)

RBS 2302 Configurations with Backup

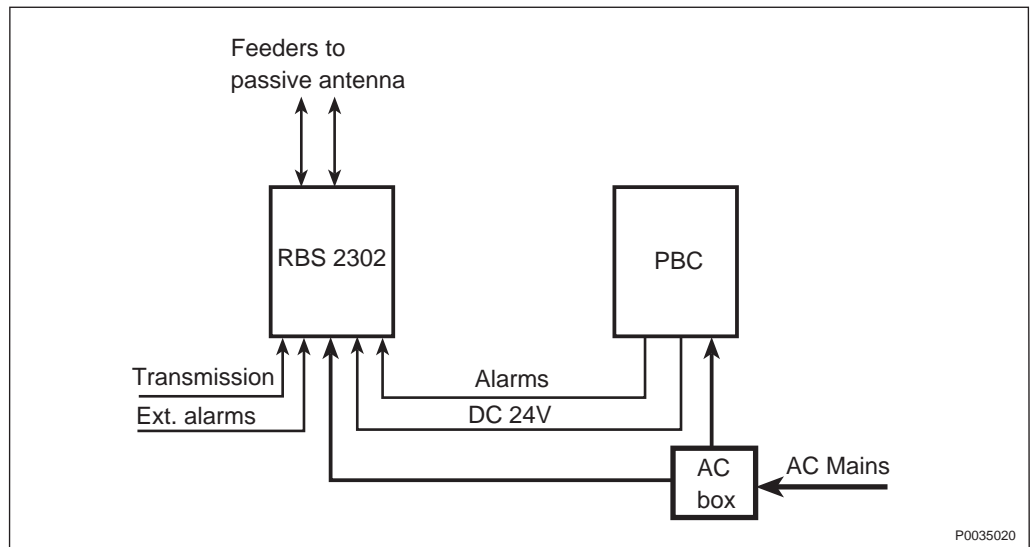

Figure 8 Extended backup, 2 TRX (R1P1)

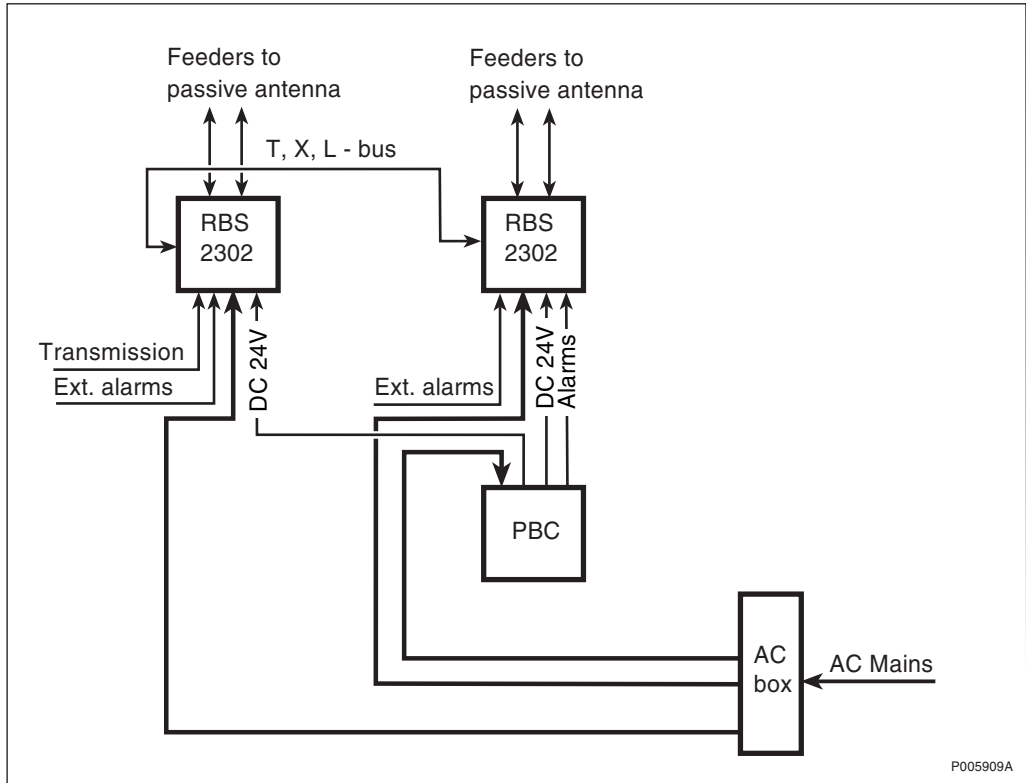

Figure 9 Extended backup, 4 TRX (R2P1)

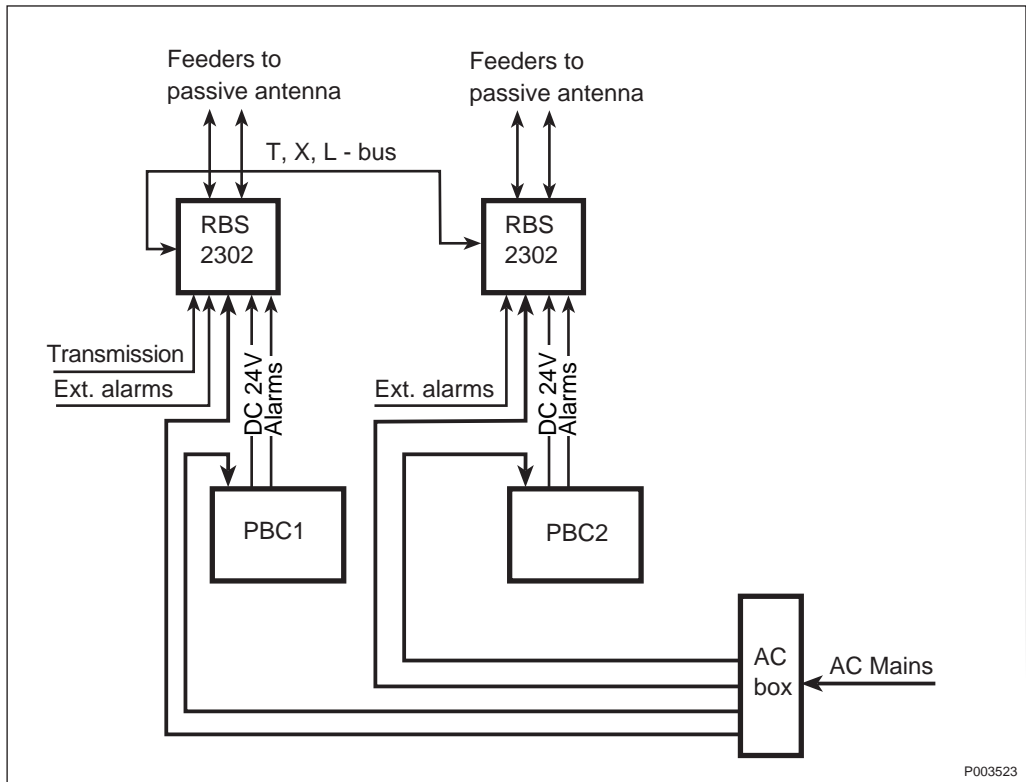

Figure 10 Extended backup, 4 TRX (R2P2)

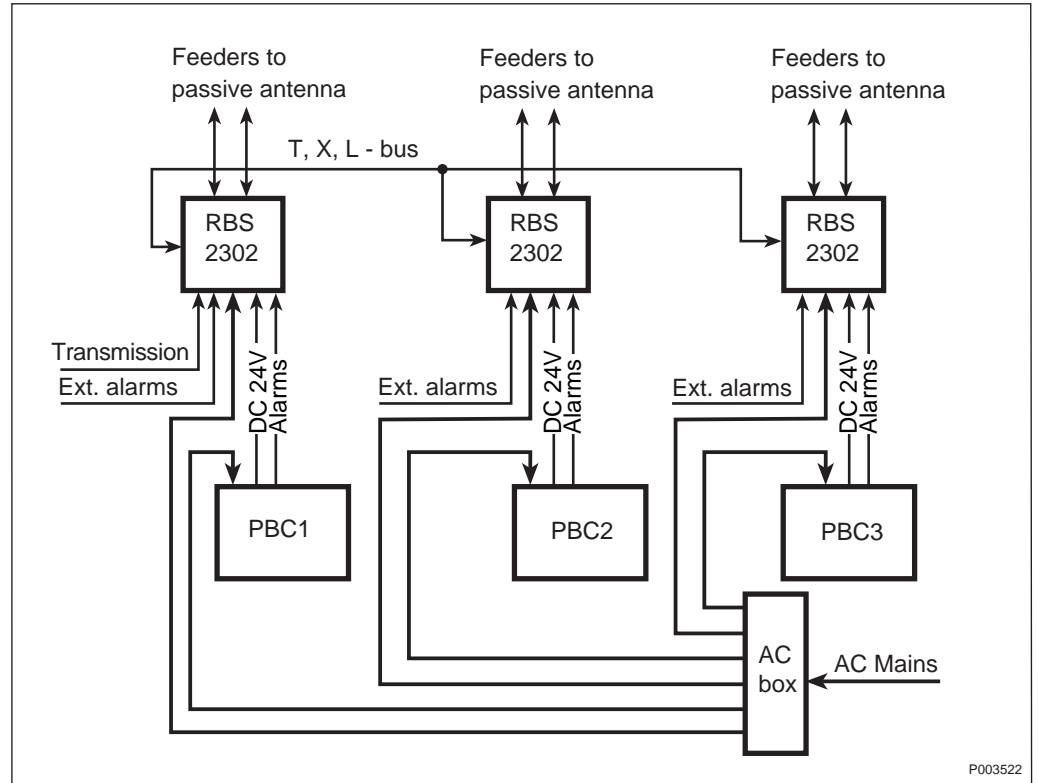

Figure 11 Extended backup, 6 TRX (R3P3)

MAXITE™ Basic Configurations

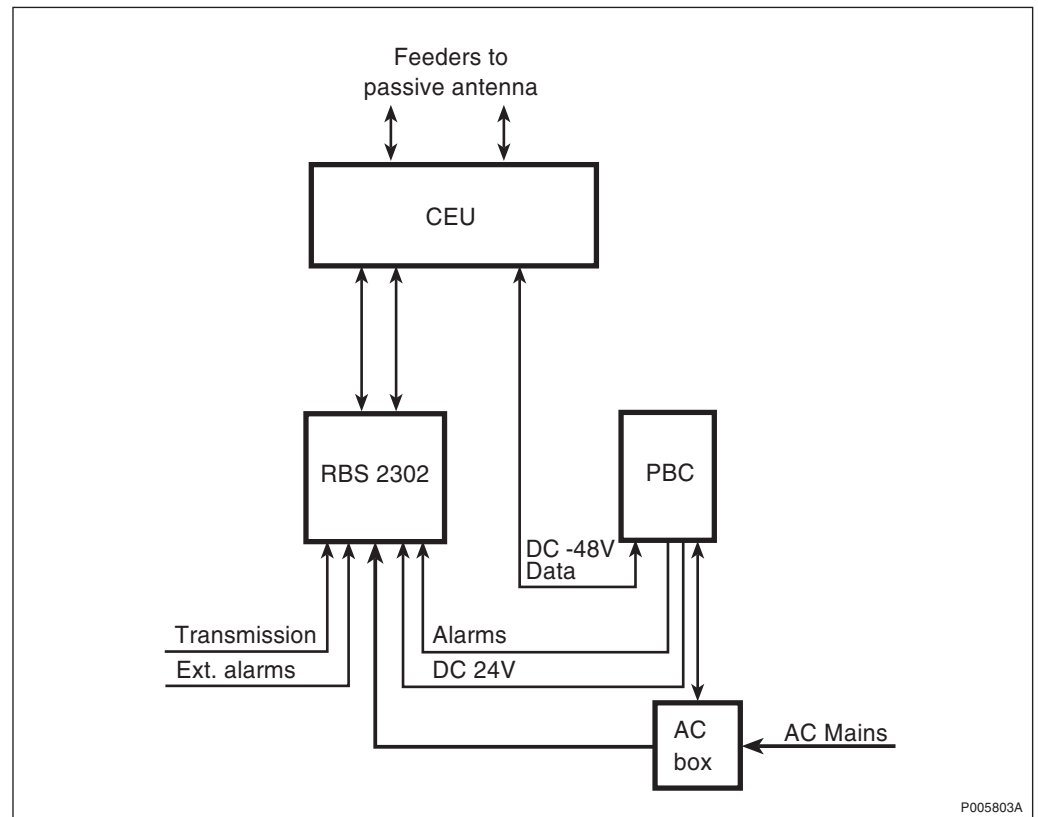

Figure 12 Basic Configuration 2 TRX (R1P1A1)

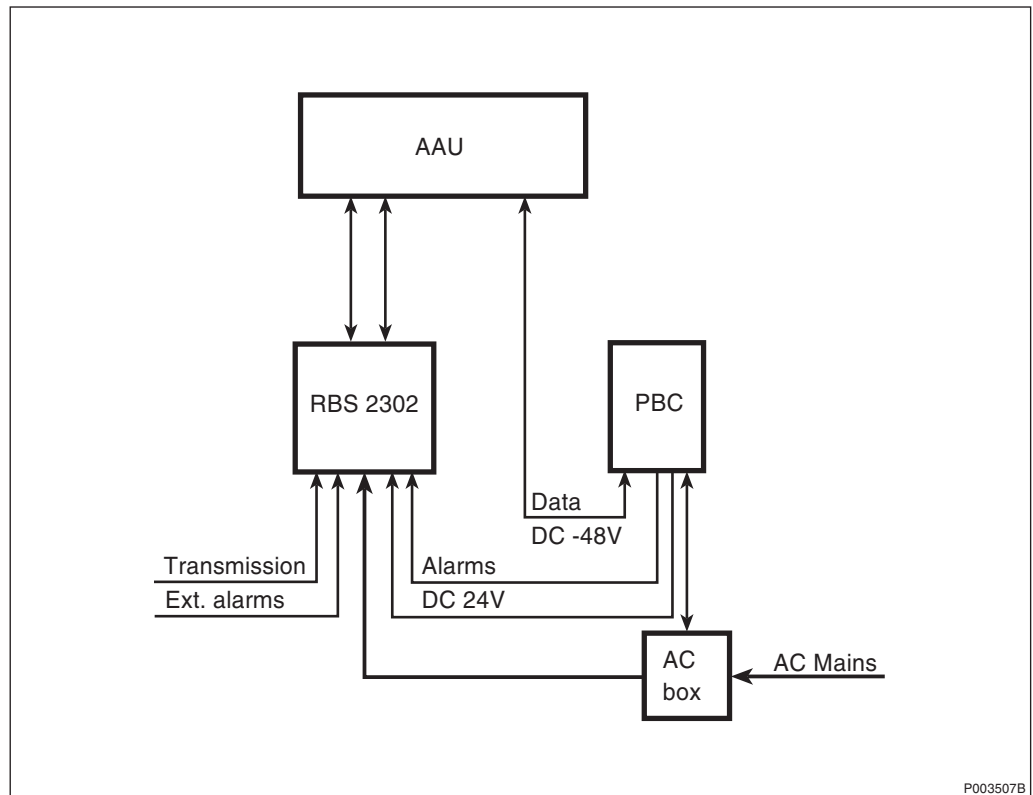
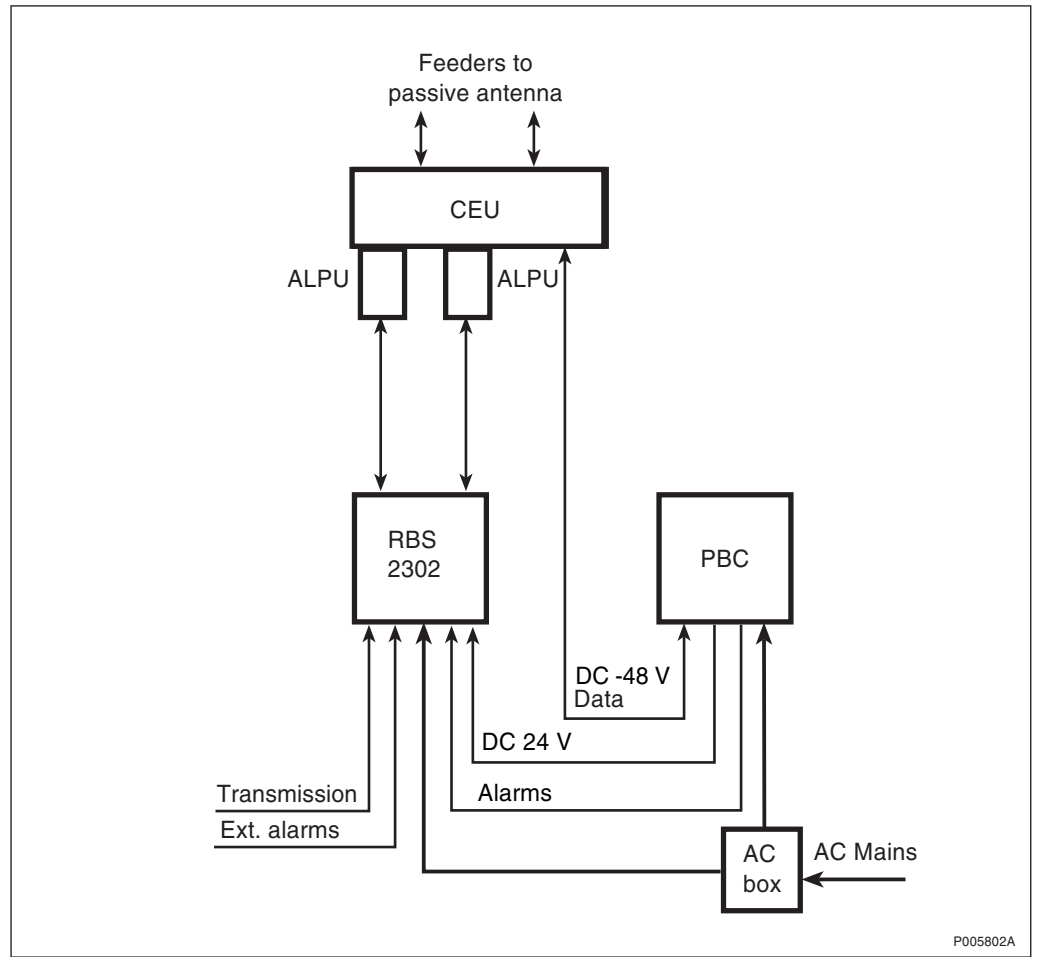

Figure 13 Basic Configuration 2 TRX (R1P1A1)



P005802A

Figure 14 Basic Configuration 2 TRX with optional Lightning Protection (RIP1A1AL1)

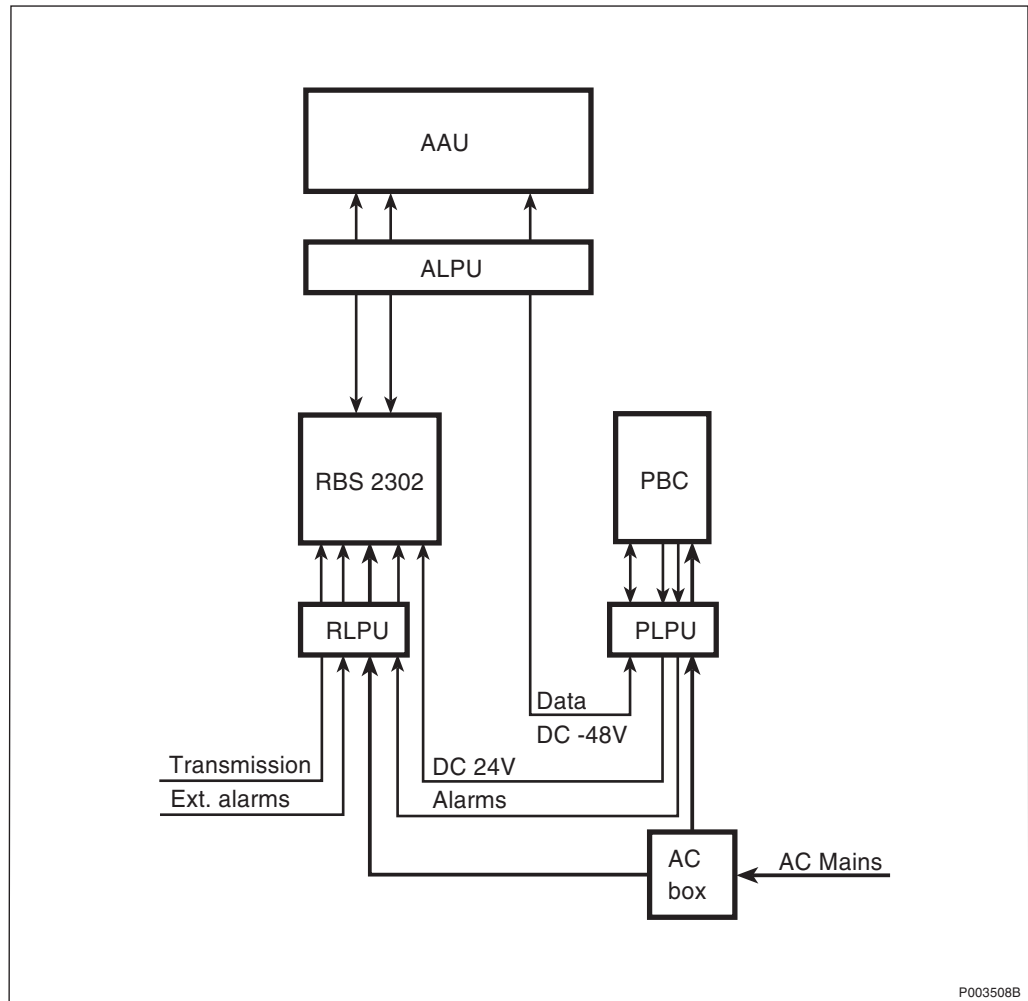
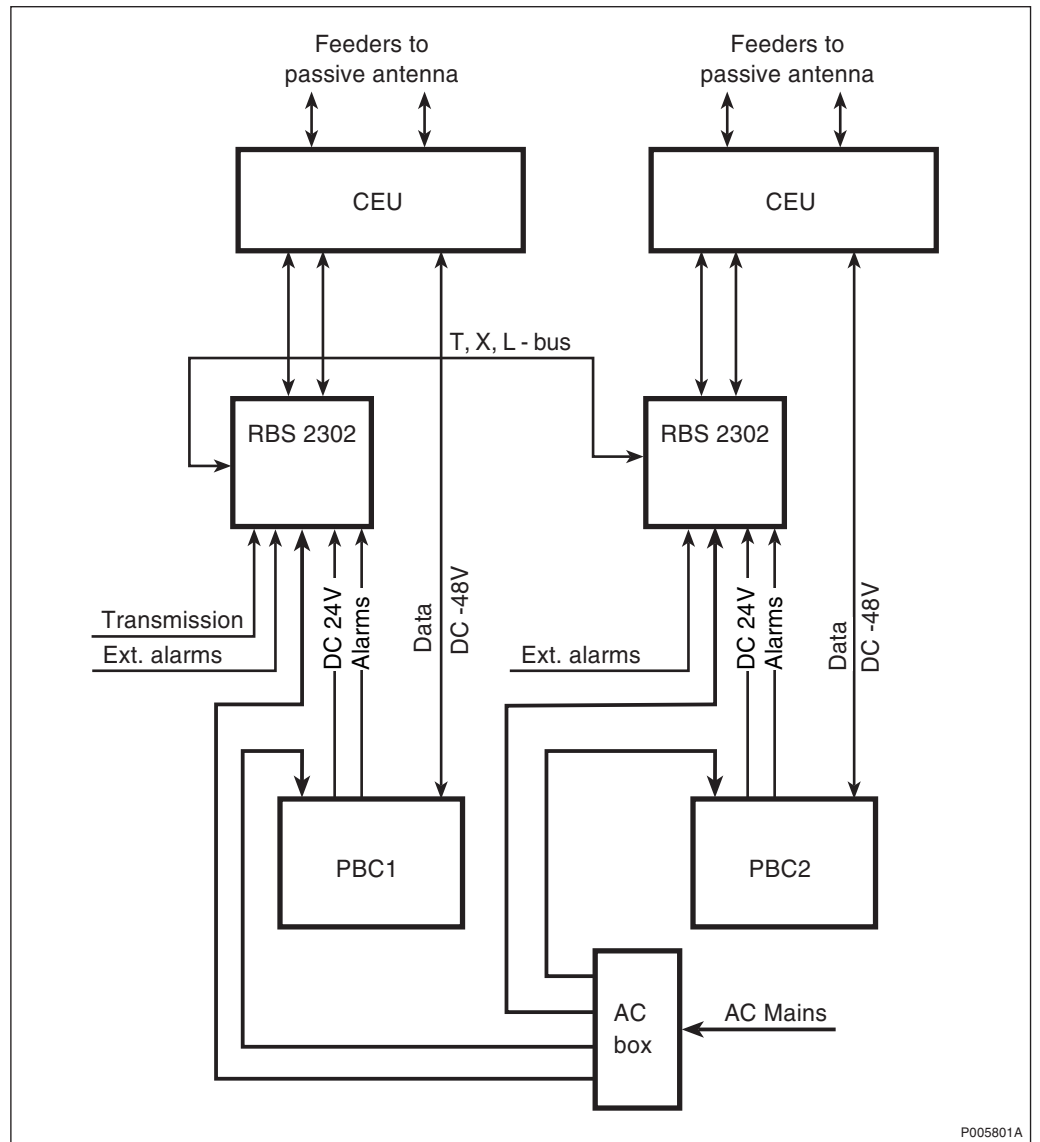

Figure 15 Basic Configuration 2 TRX with optional Lightning Protection (R1P1A1A1)



P005801A

Figure 16 Basic configuration 4 TRX (R2P2A2)

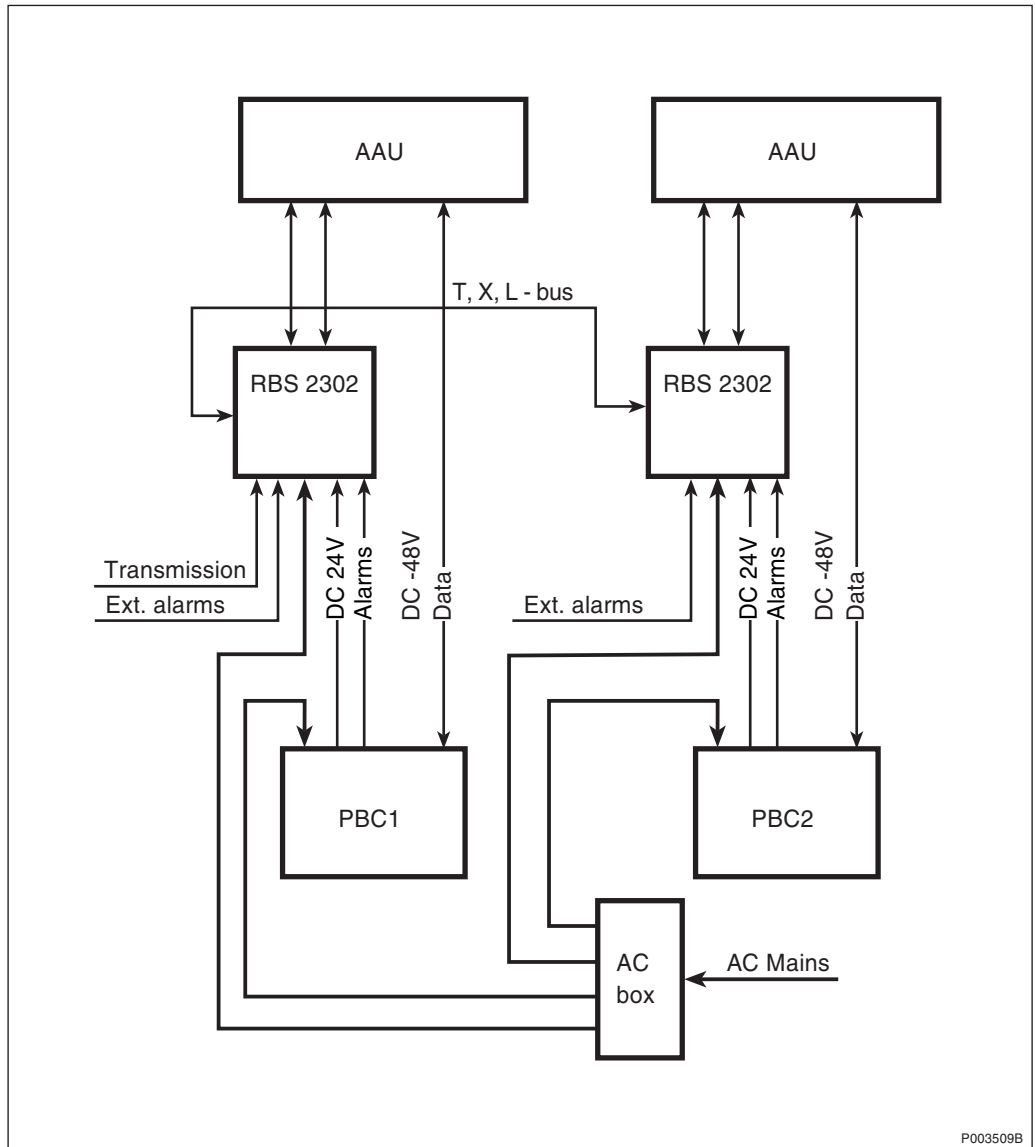

Figure 17 Basic configuration 4 TRX (R2P2A2)

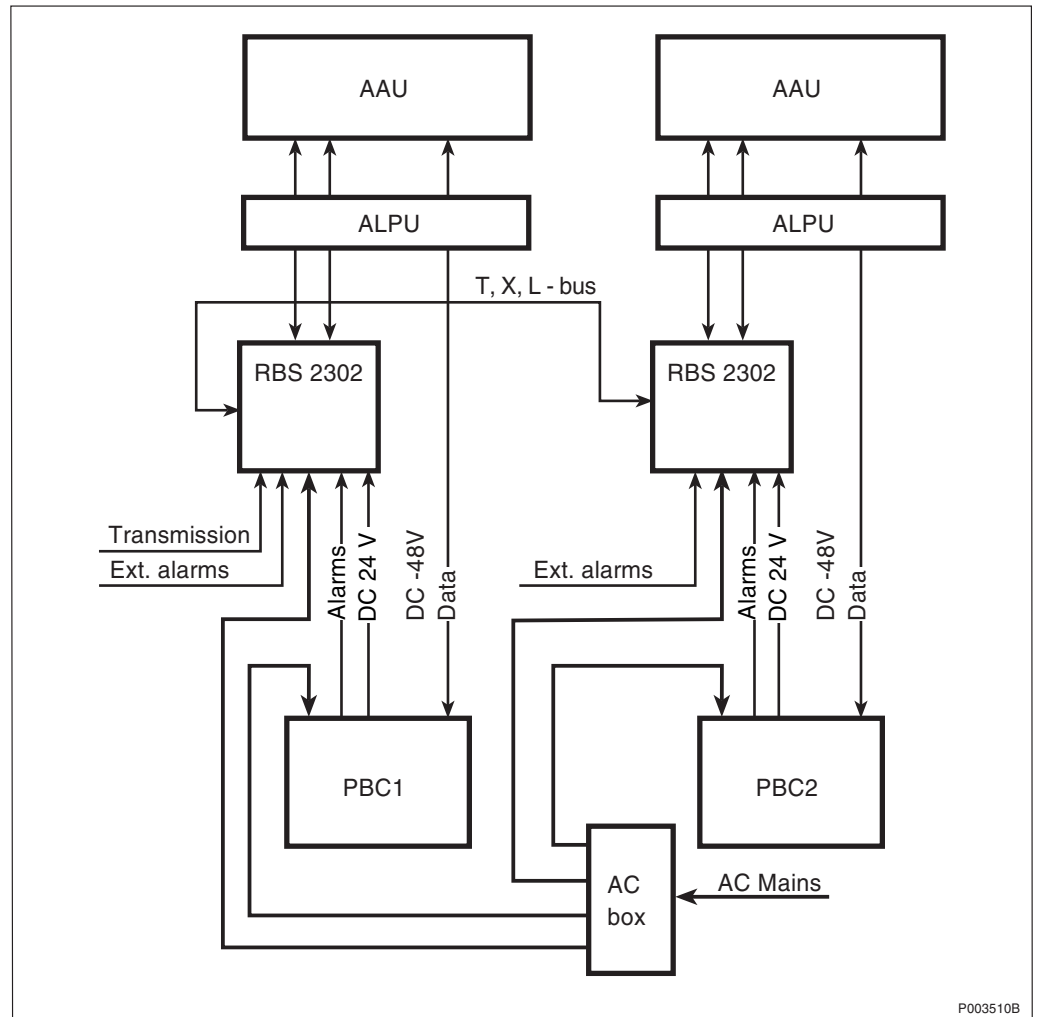
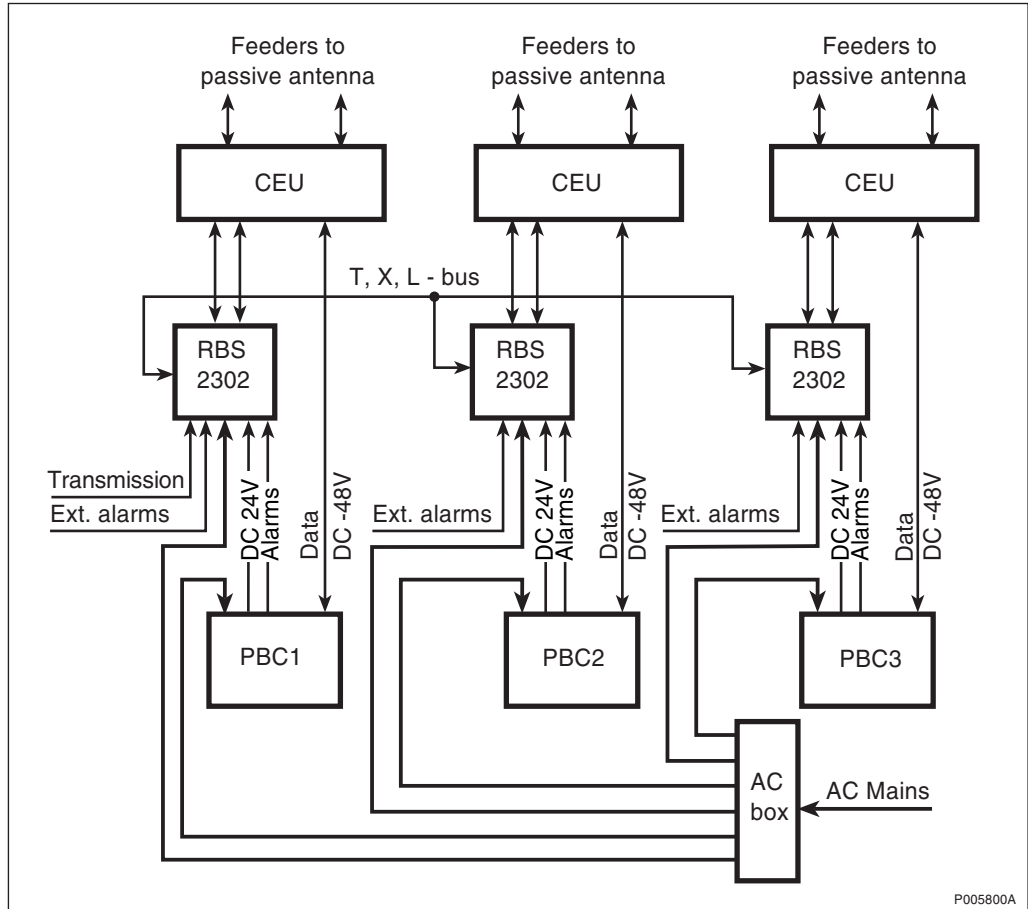

Figure 18 Basic configuration 4 TRX with optional Lightning Protection (R2P2A2AL2)



P005800A

Figure 19 Basic configuration 6 TRX (R3P3A3)

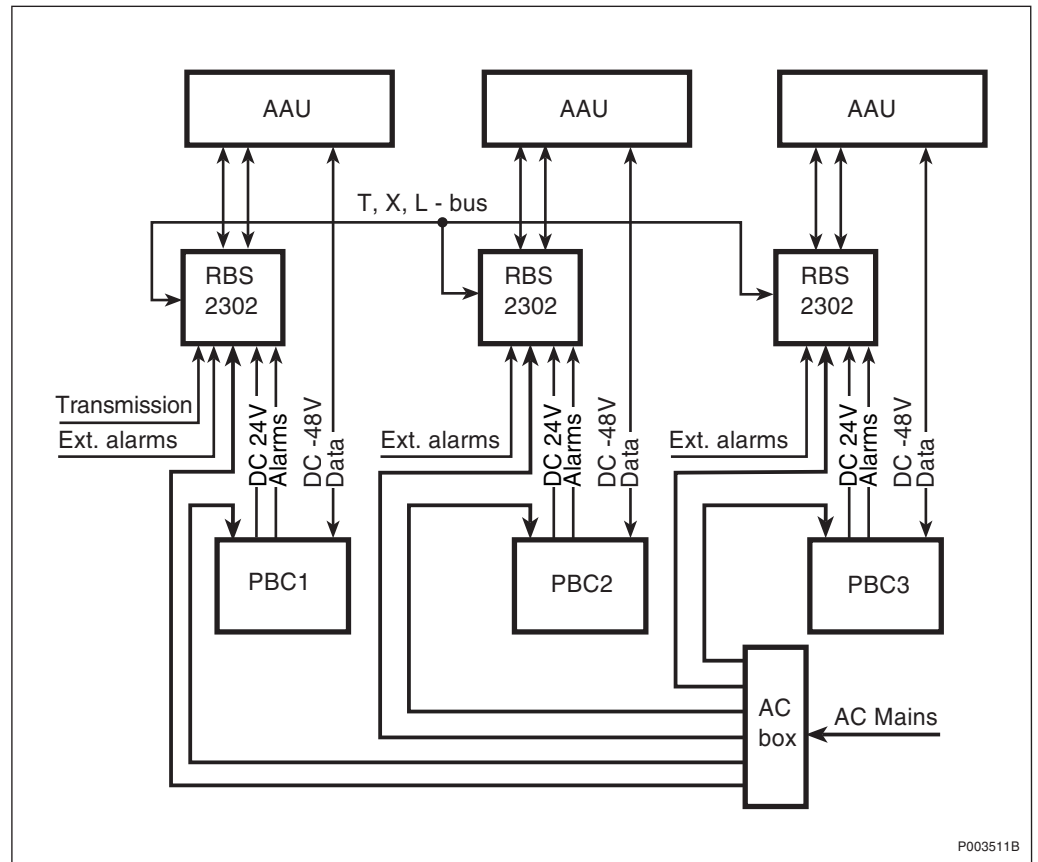

Figure 20 Basic configuration 6 TRX (R3P3A3)

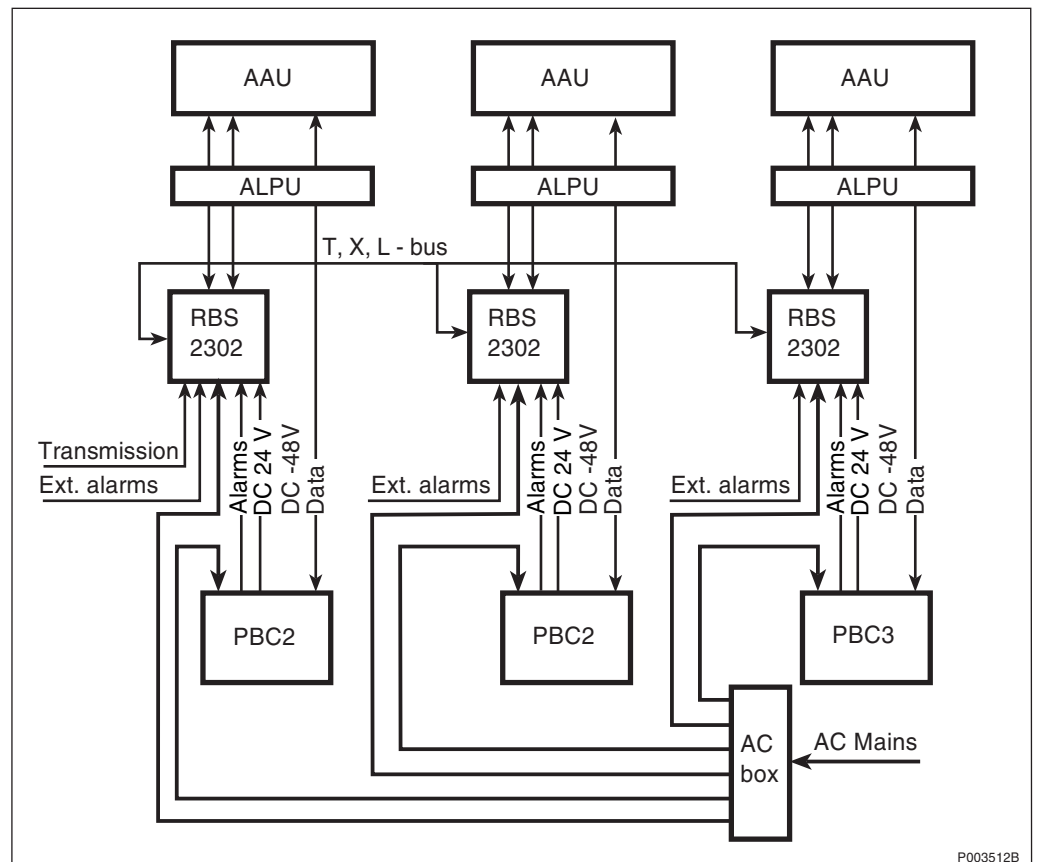

Figure 21 Basic configurations 6 TRX with optional Lightning Protection (R3P3A3AL3)

Highway Configurations

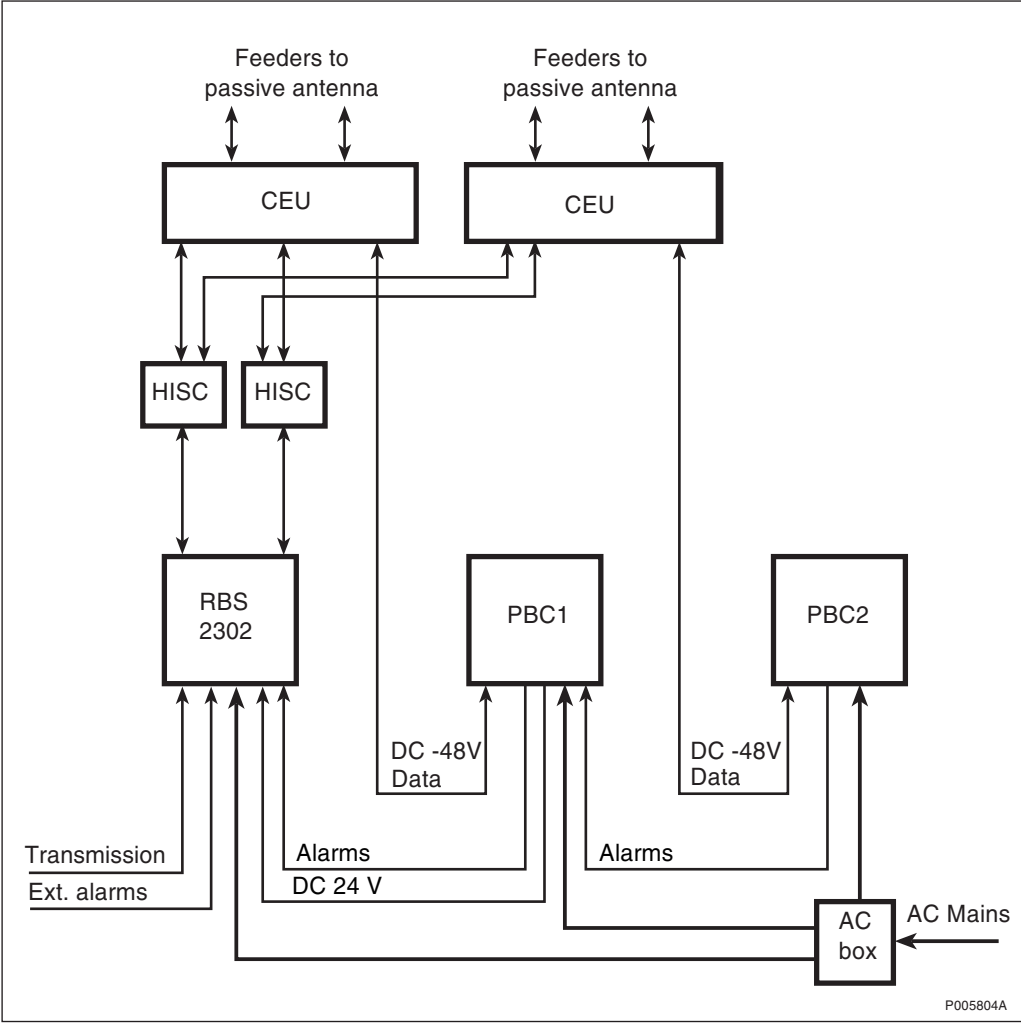

Figure 22 Highway Configuration 2 TRX (R1P2A2H1)

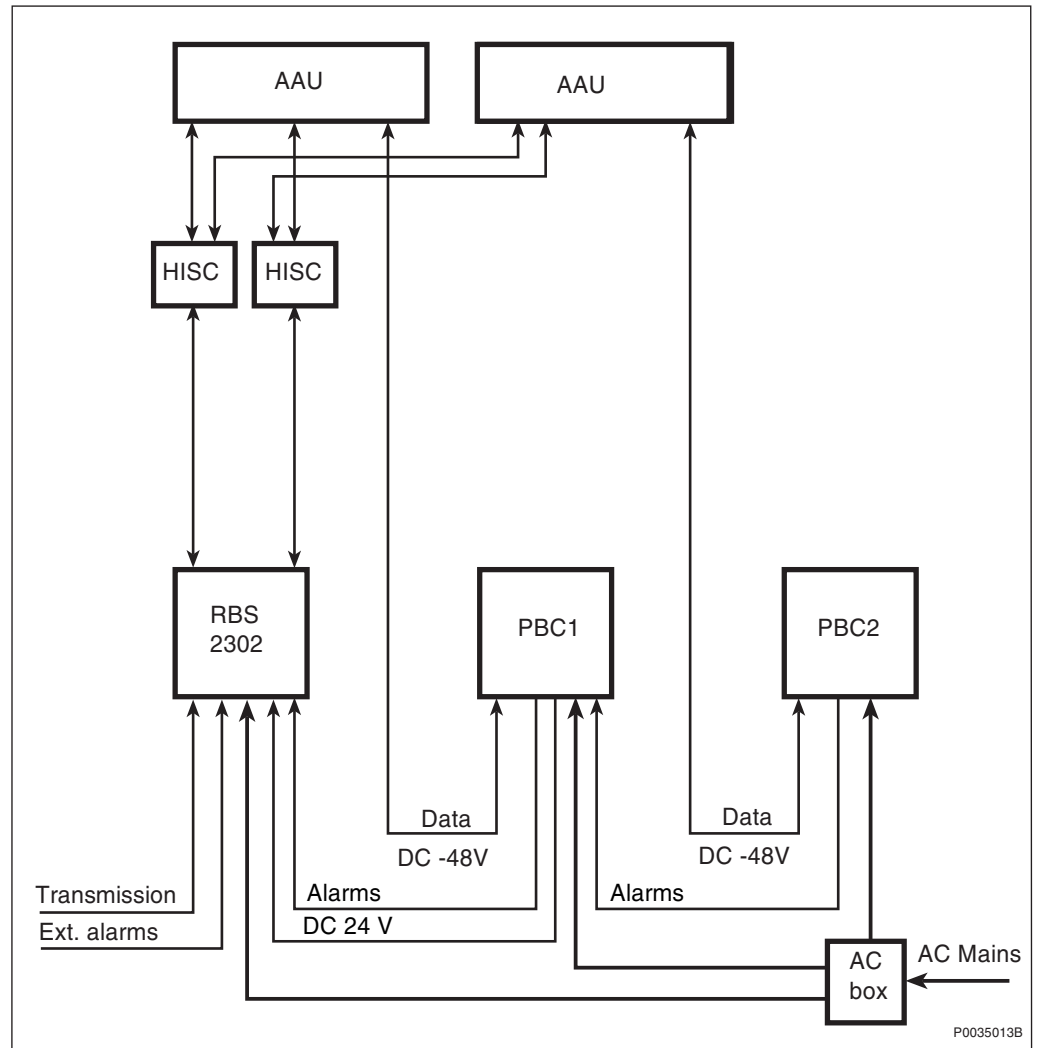

Figure 23 Highway Configuration 2 TRX (RIP2A2H1)

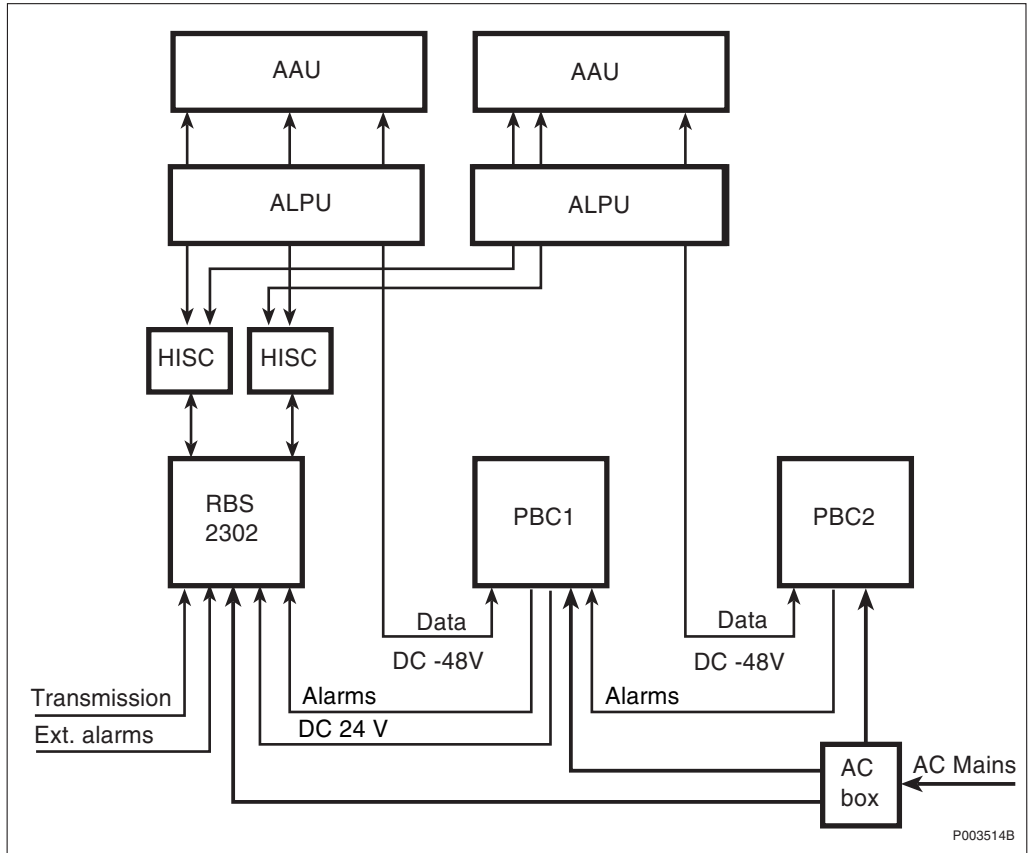

Figure 24 Highway Configuration 2 TRX with optional Lightning Protection (R1P2A2H1AL2)

+55°C Configurations

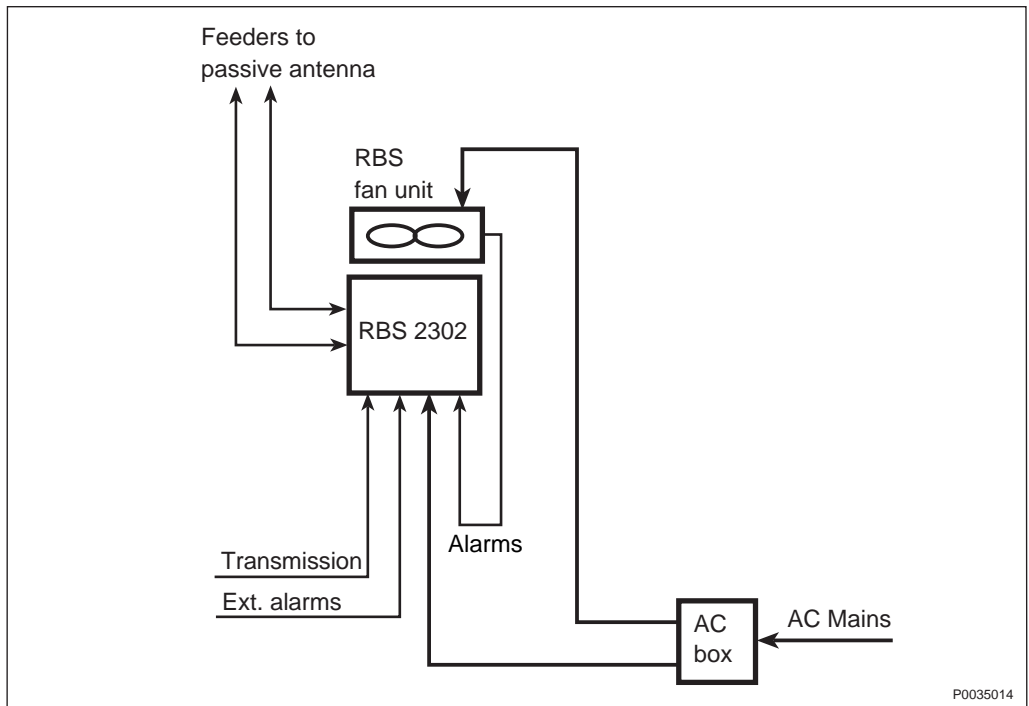

Figure 25 2 TRX, +55°C (R1/RF1)

6 Site Configurations, RBS 2000 Small Indoor

6.1 Terminology

| | |
|----------|--|
| AGW | A gateway between UDP/TCP/IP traffic on Ethernet to A-bis (LAPD) traffic on an E1 interface to the RBS. |
| Far End | Far End is a physical node in a network. It is the node in the network closest to RBS (that is, not another RBS). The Far End referred to is different nodes within BSS, such as DXX, Mini DXC and BSC. |
| HDSL | By use of HDSL transmission it is possible to connect the RBS to physical twisted copper pairs from a BSC or transmission terminal for the A-bis interface. The distance can be longer than with traditional line terminals. |
| RBS 2401 | Small Indoor Radio Base Station |

6.2 System Overview

6.2.1 Site Configurations - Overview

The table below shows the possible site configurations for Small Indoor RBS products.

All possible configurations may not be described with a figure.

The short number is an attempt to define a site configuration in a short way.

Table 16 Small Indoor RBS site configurations

| Short No. | Slogan | RBS 2401 | HDSL | AGW |
|--|-------------|----------|------|-----|
| | | (R) | (H) | (A) |
| R1, see Figure 26 on page 56. | 2 TRX | 1 | | |
| R1H1, see Figure 27 on page 56, Figure 28 on page 57 and Figure 29 on page 57. | HDSL, 2 TRX | 1 | 1 | |
| R1A1, see Figure 30 on page 58. | AGW, 2 TRX | 1 | | 1 |

6.2.2 Grounding of RBS

The protective ground shall be connected to the cabinet.

6.3 Configuration

6.3.1 Site Configurations

RBS 2401 configurations

2 TRX

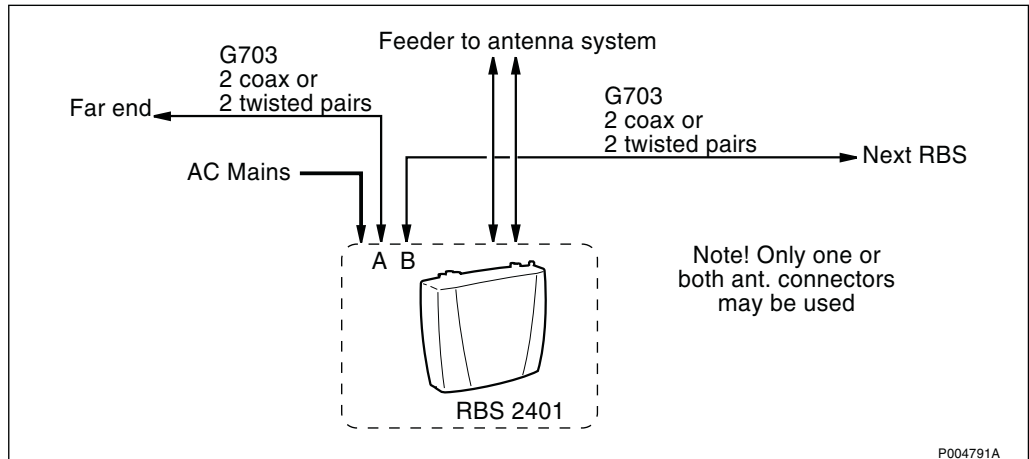

Figure 26 2 TRX (R1)

2 TRX with HDSL modem, HDSL/G.703

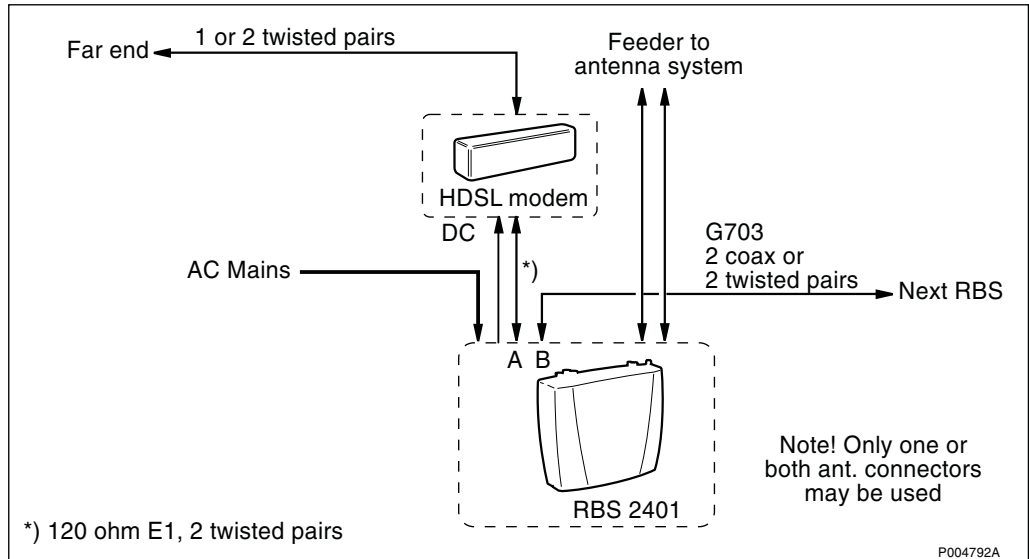

Figure 27 2 TRX with HDSL-modem, HDSL/G.703 (R1H1)

2 TRX with HDSL modem, HDSL/HDSL

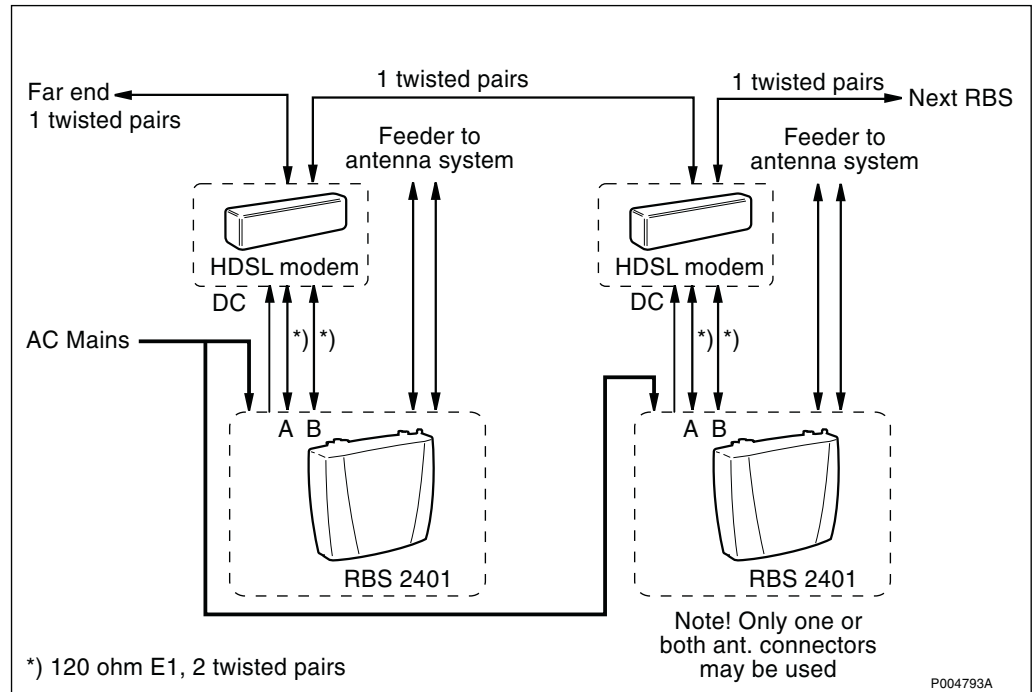

Figure 28 2 TRX with HDSL-modem, HDSL/HDSL (R1H1)

2 TRX with HDSL modem, G.703/HDSL

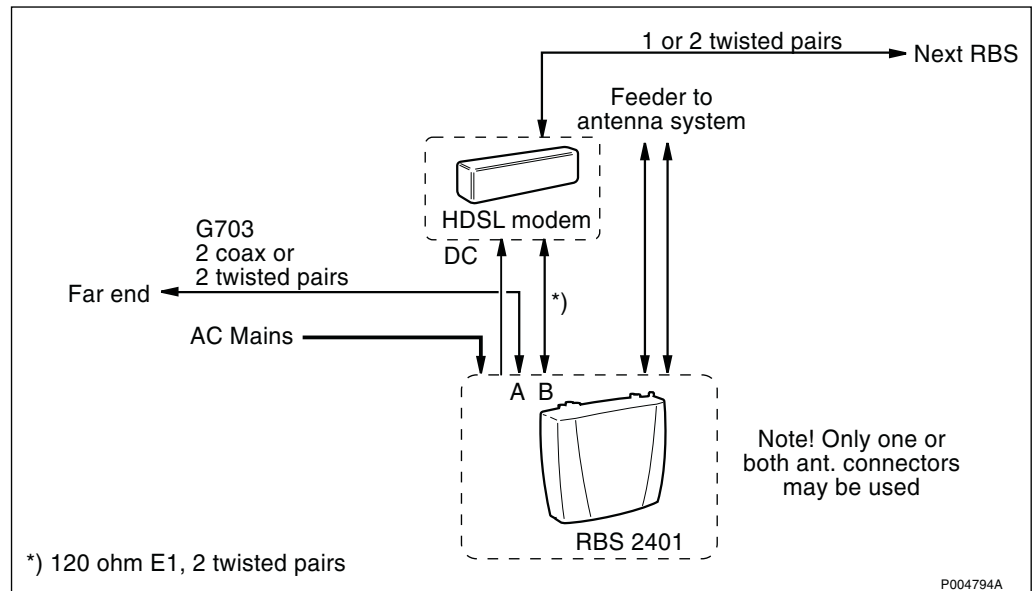

Figure 29 2 TRX with HDSL-modem, G.703/HDSL (R1H1)

2 TRX, AGW

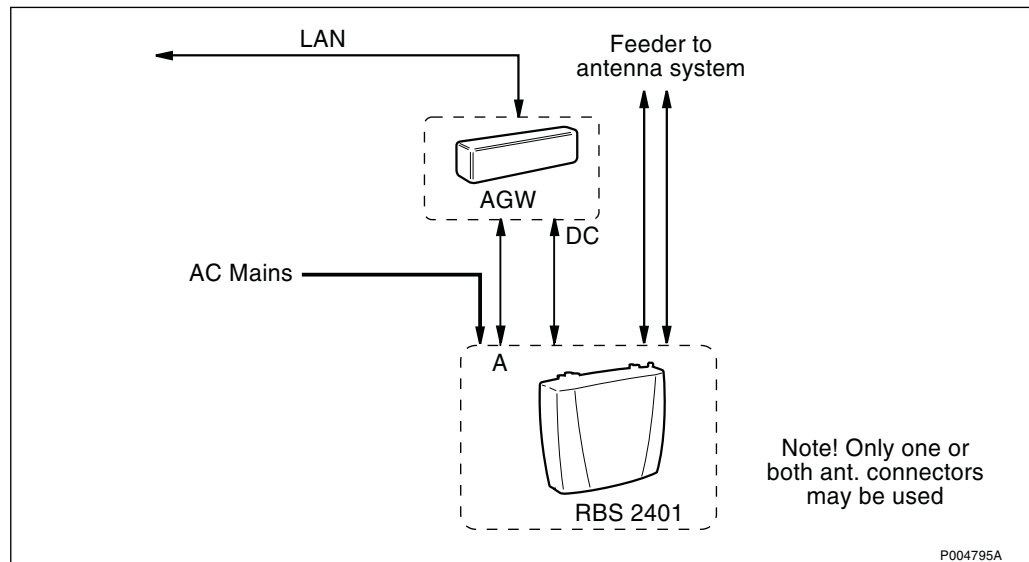

Figure 30 2 TRX, AGW (RIA1)

7 Radio Configurations, RBS 2000 Micro

This chapter describes the RBS 2000 Micro Radio Configurations and their associated performances.

7.1 References

/GSM:05.05/

GSM 05.05 (phase 2) latest version

/PCS/

The references /PCS:1-8/ are chapters in the document:

Volume 1, PCS 1900 Physical Layer 1 Specification marked:

JTC(AIR)94.08.01-231R3

7.2 Terminology

7.2.1 The Mobile Telephone System

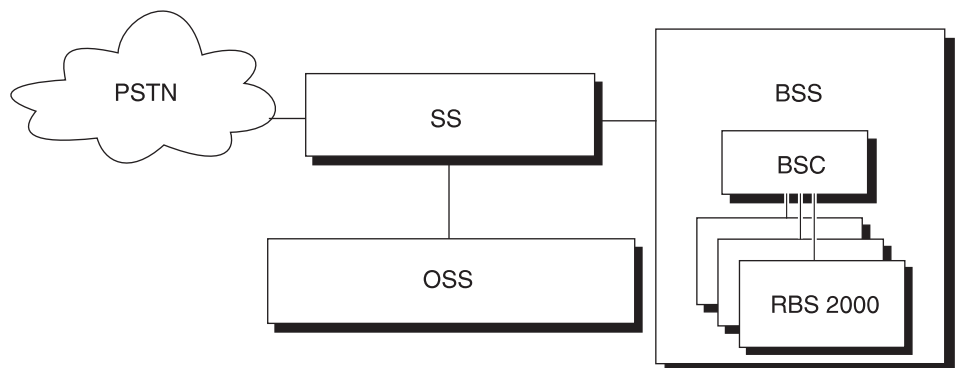

- SS Switching System
- OSS Operation Support System
- BSS Base Station System
- BSC Base Station Controller
- RBS Radio Base Station
- PSTN Public Switched Telephone Network

01_0262A

Figure 31 RBS 2000 in Ericsson's GSM System

The BSS (Base Station System) contains two functional entities:

- The BSC (Base Station Controller) handles the radio-related functions such as hand over, management of the radio network resources, and cell configuration data. It also controls radio frequency power levels in base stations and mobile stations.
- The BTS (Base Transceiver Station) is the radio equipment needed to serve one cell. It consists of the antenna system, the radio frequency power amplifiers and all the digital signal processing equipment. RBS 2000 contains equipment for one to three BTSs.

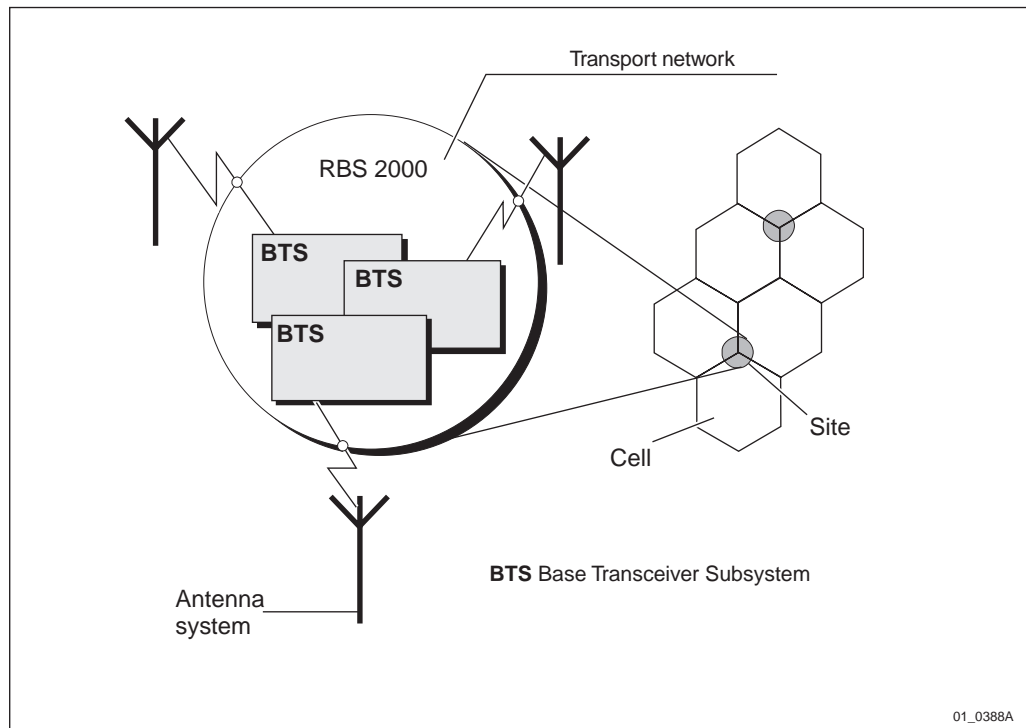

Figure 32 An RBS 2000 site with three cells

7.2.2 Antenna System

Is constituted by all RF transmission and reception antennas, directed to cover the same area or multicasting configuration.

Antenna Reference Point (ARP)

Two ARP are defined in this document; the RBS ARP and the AAU V⁽¹⁾-ARP.

The RBS ARP is the feeder connector on the RBS.

The AAU V-ARP is the test connector after the network that connects the outputs from different PAMs. This network is used for test purposes only.

⁽¹⁾V=Virtual

Active Antenna Unit (AAU)

The Active Antenna comprises two separate physical RF channels which include LNAs and PAs.

The AA is a unit where the LNAs and PAs are integrated with the antenna elements.

7.2.3 Basic Configuration

A maximum of two transceivers can be combined and connected to one antenna system.

The basic configuration may be multiplied or used in combination with other basic configurations to build the needed site equipment.

7.2.4 Definition

The definition of the basic configuration type thus refers to CDU_type.

$\langle \text{Basic_Config} \rangle ::= \langle \text{X} \rangle \langle \text{F} \rangle \text{d_} \langle \text{A} \rangle . \langle \text{T} \rangle \backslash \langle \text{N} \rangle$

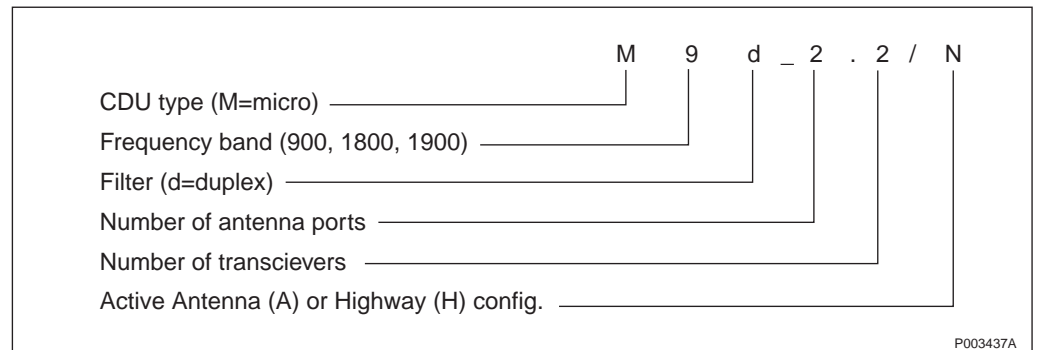

Figure 33 Type definition example

Type definitions:

$\langle \text{N} \rangle ::= \langle \text{Variant} \rangle ::= \text{A, H}$

A = Active Antenna

C = Coverage Extension Unit

H = Active Antenna or Coverage Extension Unit Highway Configuration

$\langle \text{X} \rangle ::= \langle \text{Basic CDU-type} \rangle ::= \text{M}$

M = Microbase RBS

$\langle \text{F} \rangle ::= \langle \text{Frequency Band} \rangle ::= \text{9/18/19}$

9 = 900 MHz

18 = 1800 MHz

19 = 1900 MHz

$\langle \text{option} \rangle ::= \text{d}$

d = Duplexer included in CDU

$\langle \text{A} \rangle ::= \langle \text{No of Antenna Ports} \rangle$

$\langle \text{T} \rangle ::= \langle \text{No of Transceivers} \rangle$

7.2.5 Site/Cell Configuration (SCC)

This is a geographical concept that describes how an area around one radio base station site is divided into radio traffic areas.

7.3 Frequency Bands

| | | |
|----------|----------|-----------------|
| GSM 900 | Uplink | 890 - 915 MHz |
| | Downlink | 935 - 960 MHz |
| GSM 1800 | Uplink | 1710 - 1785 MHz |
| | Downlink | 1805 - 1880 MHz |
| GSM 1900 | Uplink | 1850 - 1910 MHz |
| | Downlink | 1930 - 1990 MHz |

7.4 General

RBS Configurations is the designated expression for the RF parts integrated in the BTS.

The functionality is:

- The output signal from one or more transmitters are combined into the same antenna system, which can be utilized as a TX/RX antenna.
- The received signal from the receive antenna system, which can be utilized as a TX/RX antenna, is distributed to receivers belonging to one RBS.

7.5 Configurations

7.5.1 TX Output Power

The value given for the RBS output power for the different configurations below is the minimum RBS output power when the transmitter is set for maximum nominal power (P_0).

The RBS output power is measured at the TX reference point, and it is dependent on the TX combining and filtering parts.

The tolerance for the RBS output power at the different settings is in compliance with /GSM:05.05:4.1.2/ for GSM 900 and GSM 1800, and /PCS:5.3.3/ for GSM 1900.

When two or more transmitters are combined to one antenna, the transmitters must be operated with a minimum of 400 kHz separation between the centre frequency of adjacent carriers. This limitation is not caused by the combiner but the RBS itself.

With TX diversity configured both transmitters use the same ARFCN.

The maximum nominal power, P_0 , measured on the cabinet output RF connector (which in this case corresponds to the TX Reference Point) is minimum +32 dBm. This output power level is valid for all frequency bands.

With TX diversity configured the output power is minimum +32 dBm at each ARP.

If an AAU configuration is used, the maximum nominal power, P_0 , defined as the EIRP measured in the far field (the EIRP can be calculated to correspond to a equivalent RF power before transferring to the integrated antenna elements) is minimum +55 dBm for the AAU 500 W and +59 dBm for the AAU 1250 W.

Nominal A-bis configuration power parameters for the Micro Base Station RBS 2301:

| | |
|----------|--------------------------|
| 900 MHz | 21 - 33 _(dec) |
| 1800 MHz | 21 - 33 _(dec) |
| 1900 MHz | 21 - 33 _(dec) |

Note: Only steps by 2 is configureable (from the highest value).

TX diversity configuration power parameters for the Micro Base Station RBS 2301:

| | |
|----------|---------------------|
| 900 MHz | 35 _(dec) |
| 1800 MHz | 35 _(dec) |
| 1900 MHz | 35 _(dec) |

7.5.2 RX Description

The receiver system performance is dependent on the configuration.

Actual Sensitivity Level

Is defined in and complying with the level where RBS meets the reference sensitivity performance defined in:

- /GSM:05.05:6.2 / for GSM 900 and GSM 1800
- /PCS:4/ and /PCS:5.1.1/ for GSM 1900.

Radio Reception

The receiver sensitivity is reduced when a third order intermodulation product, generated by the radio transmitters in the RBS, is received at the same RCFN as the useful signal.

This occurs when the distance in frequency between two simultaneous transmitters is chosen in a way that a third order intermodulation product is generated at the same frequency as the operating frequency of one of the receivers in the RBS.

Note: In RBS 2301 the receiver sensitivity will be decreased by 1 dB when a third order transmitter intermodulation product coincides in frequency with an active frequency used by the receiver.

7.5.3 Isolation Values

The isolation requirements between two antennas belonging to the same RBS is reduced and shall at least be:

- for GSM 900: 15 dB
- for GSM1800 and GSM 1900: 20 dB
- for Maxite, GSM 1800 and GSM 1900: 30 dB

7.5.4 Omnidirectional Antenna

GSM 900

- Beamwidth: For omnidirectional antennas, specification on beamwidth is replaced by the specification on gain.
- Space Diversity Separation: The two antennas has a horizontal separation of at least 0.5 wavelength c/c or a vertical separation of 1.0 wavelength c/c .
- Power Handling: The Antenna is able to handle a continuous output of 10 W.

GSM 1800/GSM 1900

- Beamwidth: For omnidirectional antennas, specification on beamwidth is replaced by the specification on gain.
- Space diversity separation: The two antennas has a horizontal separation of at least 0.5 wavelengths c/c or a vertical separation of 1.0 wavelengths c/c .
- Power Handling: The antenna is able to handle a continuous output power of 10 W.

7.5.5 Sector Antenna

GSM 900

For sector antennas, the beamwidth is specified both as the traditional -3 dB beamwidth and also as a beamwidth at the 0 dBi (isotropic) level:

- Horizontal: Min. 80° at the -3 dB point
Min. 180° at the -10 dB level
- Vertical: Max. 75° at the -3 dB point

The antenna is able to handle a continuous output power of 10 W.

GSM 1800/GSM 1900

For sector antennas, the beamwidth is specified both as the traditional -3 dB beamwidth and also as a beamwidth at the 0 dBi (isotropic) level:

Horizontal: Min. 60° at the -3 dB point
 Min. 120° at the -10 dB level
 Vertical: Max. 50° at the -3 dB point

The antenna is able to handle a continuous output power of 10 W.

7.5.6 Active Antenna

GSM 1800

For active sector antennas 500 W, the beamwidth is specified both as the traditional -3 dB beamwidth and also as a beamwidth at the 0 dBi (isotropic) level:

Horizontal: Min. 65° at the -3 dB point
 Min. 120° at the -10 dB level
 Vertical: Max. 7° at the -3 dB point

GSM 1900

For active sector antennas 1250 W, the beamwidth is specified both as the traditional -3 dB beamwidth and also as a beamwidth at the 0 dBi (isotropic) level:

Horizontal: Min. 65° at the -3 dB point
 Min. 120° at the -10 dB level
 Vertical: Max. 3° at the -3 dB point

7.5.7 Supported Basic Configurations

RBS 2301

The following Basic Configurations are supported:

Table 17 RBS 2301 Supported Configurations

| No. Cab. | Config./Band | SCC ²⁾ | Allowed Config. ³⁾ | GSM 900 | GSM 1800 | GSM 1900 |
|----------|------------------------|-------------------|-------------------------------|---------|----------|----------|
| 1 | M9d_2.2 ¹⁾ | | | x | | |
| 1 | M9d_2.2 | 1x2 | (0..2) | x | | |
| 1 | M9d_1.2 | 1x2 | (0..2) | x | | |
| 1 | M18d_2.2 ¹⁾ | | | | x | |
| 1 | M18d_2.2 | 1x2 | (0..2) | | x | |
| 1 | M18d_1.2 | 1x2 | (0..2) | | x | |
| 1 | M19d_2.2 ¹⁾ | | | | | x |
| 1 | M19d_2.2 | 1x2 | (0..2) | | | x |
| 1 | M19d_1.2 | | | | | x |

- 1) 1 TRX only
- 2) Max. number of cells times max. number of TRUs per cell
- 3) Allowed number of TRUs in (cell 1) (cell 2) (cell 3), (Min..Max)

RBS 2302

The following Basic Configurations are supported:

Table 18 RBS 2302 Supported Configurations

| No. Cab. | Config./Band | SCC ²⁾ | Allowed Config. ³⁾ | GSM 900 | GSM 1800 | GSM 1900 |
|----------|--|-------------------|-------------------------------|---------|----------|----------|
| 1 | M9d_2.2 | 1x2 | (0..2) | x | | |
| 2 | M9d_2.2 + M9d_2.2 ¹⁾ | 2x2 | (0..4) | x | | |
| 3 | M9d_2.2 + M9d_2.2 + M9d_2.2 ¹⁾ | 3x2 | (0..6) | x | | |
| 2 | M9d_4.4 ¹⁾ | 1x4 | (0..4) | x | | |
| 3 | M9d_6.6 ¹⁾ | 1x6 | (0..6) | x | | |
| 1 | M9d_1.2 | 1x2 | (0..2) | x | | |
| 1 | M9d_2.2\C | 1x2 | (0..2) | x | | |
| 2 | M9d_2.2\C + M9d_2.2\C | 2x2 | (0..4) | x | | |
| 3 | M9d_2.2\C + M9d_2.2\C + M9d_2.2\C | 3x2 | (0..6) | x | | |
| 2 | M9d_4.4\C | 1x4 | (0..4) | x | | |
| 3 | M9d_6.6\C | 1x6 | (0..6) | x | | |
| 1 | M9d_2.2\H | 1x2 | (0..2) | x | | |
| 1 | M18d_2.2 | 1x2 | (0..2) | | x | |
| 2 | M18d_2.2 + M18d_2.2 ¹⁾ | 2x2 | (0..4) | | x | |
| 3 | M18d_2.2 + M18d_2.2 + M18d_2.2 ¹⁾ | 3x2 | (0..6) | | x | |
| 2 | M18d_4.4 ¹⁾ | 1x4 | (0..4) | | x | |
| 3 | M18d_6.6 ¹⁾ | 1x6 | (0..6) | | x | |
| 1 | M18d_2.2\A | 1x2 | (0..2) | | x | |
| 2 | M18d_2.2\A + M18d_2.2\A | 2x2 | (0..4) | | x | |
| 3 | M18d_2.2\A + M18d_2.2\A + M18d_2.2\A | 3x2 | (0..6) | | x | |
| 2 | M18d_4.4\A ¹⁾ | 1x4 | (0..4) | | x | |
| 3 | M18d_6.6\A ¹⁾ | 1x6 | (0..6) | | x | |
| 1 | M18d_2.2\H | | | | x | |
| 1 | M18d_1.2 | 1x2 | (0..2) | | x | |
| 1 | M19d_2.2 | 1x2 | (0..2) | | | x |

| | | | | | | |
|---|--|-----|--------|--|--|---|
| 2 | M19d_2.2 + M19d_2.2 ¹⁾ | 2x2 | (0..4) | | | x |
| 3 | M19d_2.2 + M19d_2.2 + M19d_2.2 ¹⁾ | 3x2 | (0..6) | | | x |
| 2 | M19d_4.4 ¹⁾ | 1x4 | (0..4) | | | x |
| 3 | M19d_6.6 ¹⁾ | 1x6 | (0..6) | | | x |
| 1 | M19d_2.2\A | 1x2 | (0..2) | | | x |
| 2 | M19d_2.2\A + M19d_2.2\A ¹⁾ | 2x2 | (0..4) | | | x |
| 3 | M19d_2.2\A + M19d_2.2\A + M19d_2.2\A ¹⁾ | 3x2 | (0..6) | | | x |
| 2 | M19d_4.4\A ¹⁾ | 1x4 | (0..4) | | | x |
| 3 | M19d_6.6\A ¹⁾ | 1x6 | (0..6) | | | x |
| 1 | M19d_2.2\H | 1x2 | (0..2) | | | x |
| 1 | M19d_1.2 | 1x2 | (0..2) | | | x |

¹⁾ 4 TRX and 6 TRX are only valid for R7 and later.

²⁾ Max. number of cells times max. number of TRUs per cell

³⁾ Allowed number of TRUs in (cell 1) (cell 2) (cell 3), (Min..Max)

7.6 Basic Configuration GSM 900 MHz, M9d_2.2

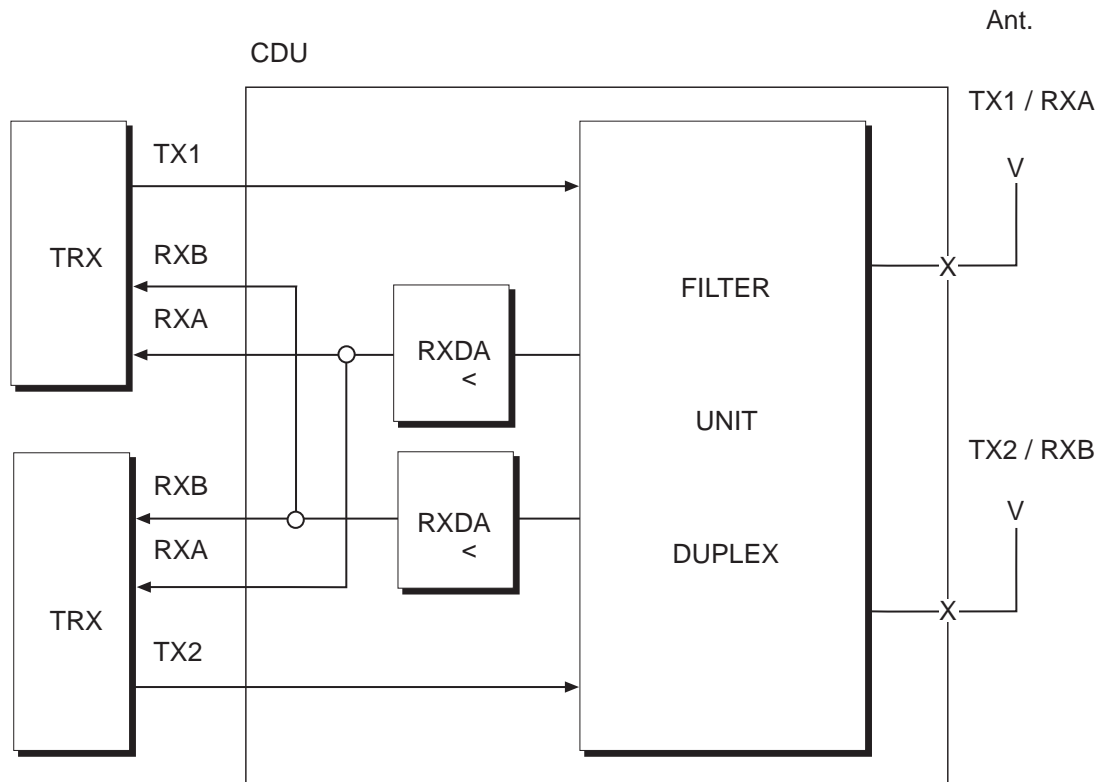

03_0348a

Figure 34 Basic configuration M9d_2.2

7.6.1 Characteristics M9d_2.2

| | |
|-----------------------|---------------|
| Max. no. of TRXs | 2 |
| No. of feeders | 2 |
| No. of antennas | 2 |
| Antenna configuration | TX/RX + TX/RX |

7.6.2 Capacity M9d_2.2

The capacity is defined at the Tx and Rx reference points marked with X.

Capacity Radio Transmission: The output power with one TX to one TX/RX output is minimum +32 dBm.

The equivalent output power with TX diversity configured is minimum +35 dBm.

Capacity Radio Reception: The actual sensitivity level is -104 dBm, or better.

7.6.3 Capacity M9d_2.2 with Integrated Omnidirectional Antenna

The typical antenna gain for the omnidirectional antenna is -1 dBi for the GSM band.

Capacity Radio Transmission: The output power with one TX to one TX/RX output is minimum +32 dBm.

The minimum corresponding Effective Isotropic Radiated Power is thus +31 dBm EIRP for the above antenna.

Capacity Radio Reception: The actual sensitivity level is -104 dBm, or better.

The corresponding sensitivity level with Omnidirectional antenna is -103 dBm, or better.

7.6.4 Capacity M9d_2.2 with Integrated Sector Antenna

The typical antenna gain for the sector antenna is 6 dBi for the GSM 900 band.

Capacity Radio Transmission: The output power with one TX to one TX/RX output is minimum +32 dBm.

The maximum corresponding Effective Isotropic Radiated Power is thus +38 dBm EIRP for the above antenna.

Capacity Radio Reception: The actual sensitivity level is -104 dBm, or better.

The corresponding sensitivity level with Sector antenna is -110 dBm, or better.

7.7 Basic Configuration GSM 900 MHz, M9d_1.2

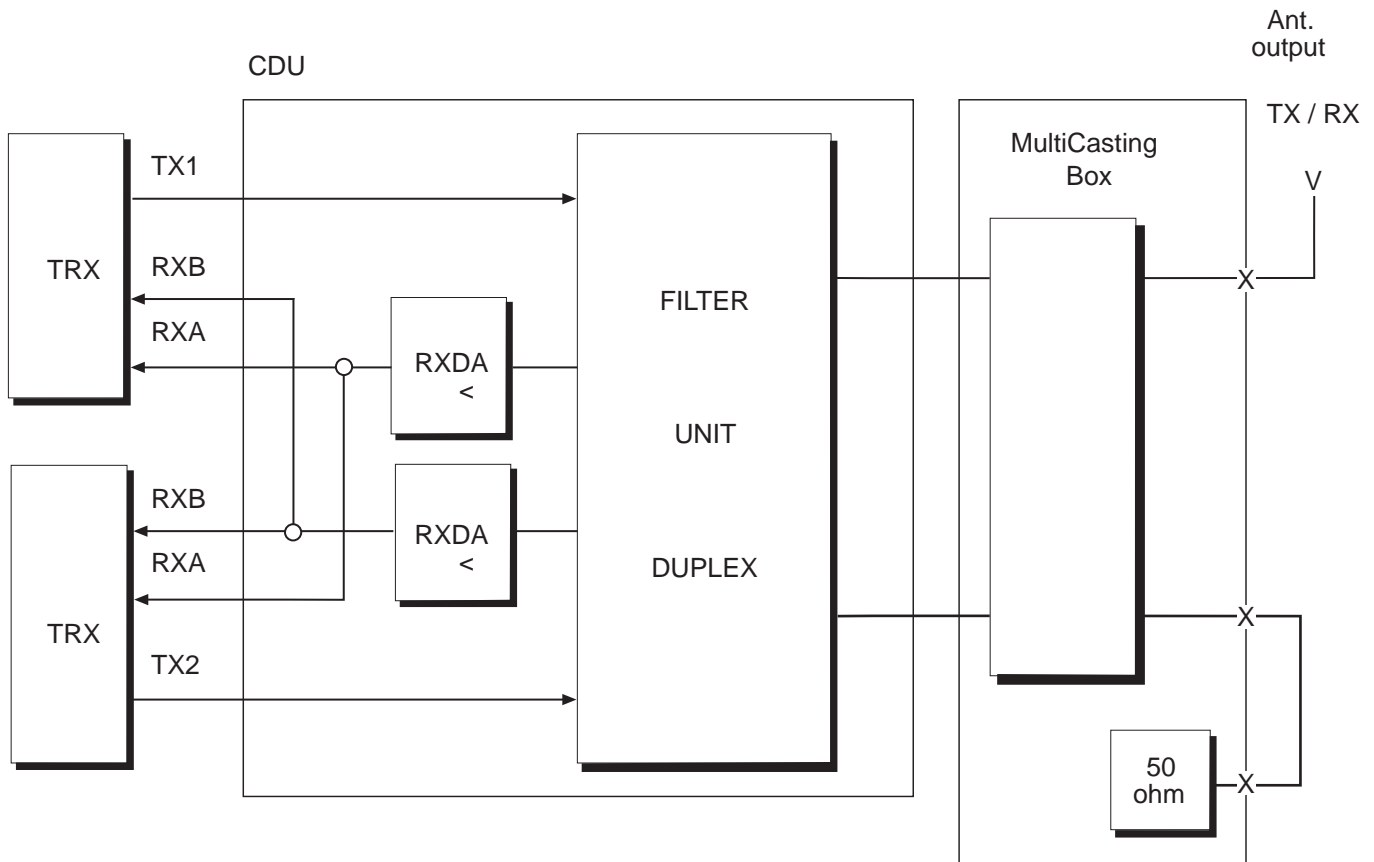

04_0348a

Figure 35 Basic configuration M9d_1.2

7.7.1 Characteristics M9d_1.2

| | |
|-----------------------------|----------------------------------|
| Max. no. of TRXs | 2 |
| No. of feeders | 1 |
| No. of antennas | 1 |
| Antenna configuration | TX/RX |
| Loss TRX-TX Reference point | Max. 4.5 dB in each output/input |
| Limitations | No RX diversity |

7.7.2 Capacity M9d_1.2 (with Multicasting Box)

The capacity is defined at the Tx and Rx reference points marked with X.

Capacity Radio Transmission: The output power from one TX to each TX/RX output/input is minimum +27.5 dBm.

Capacity Radio Reception: The actual sensitivity level is -99.5 dBm, or better.

7.8 Basic Configuration M9d_2.2\C

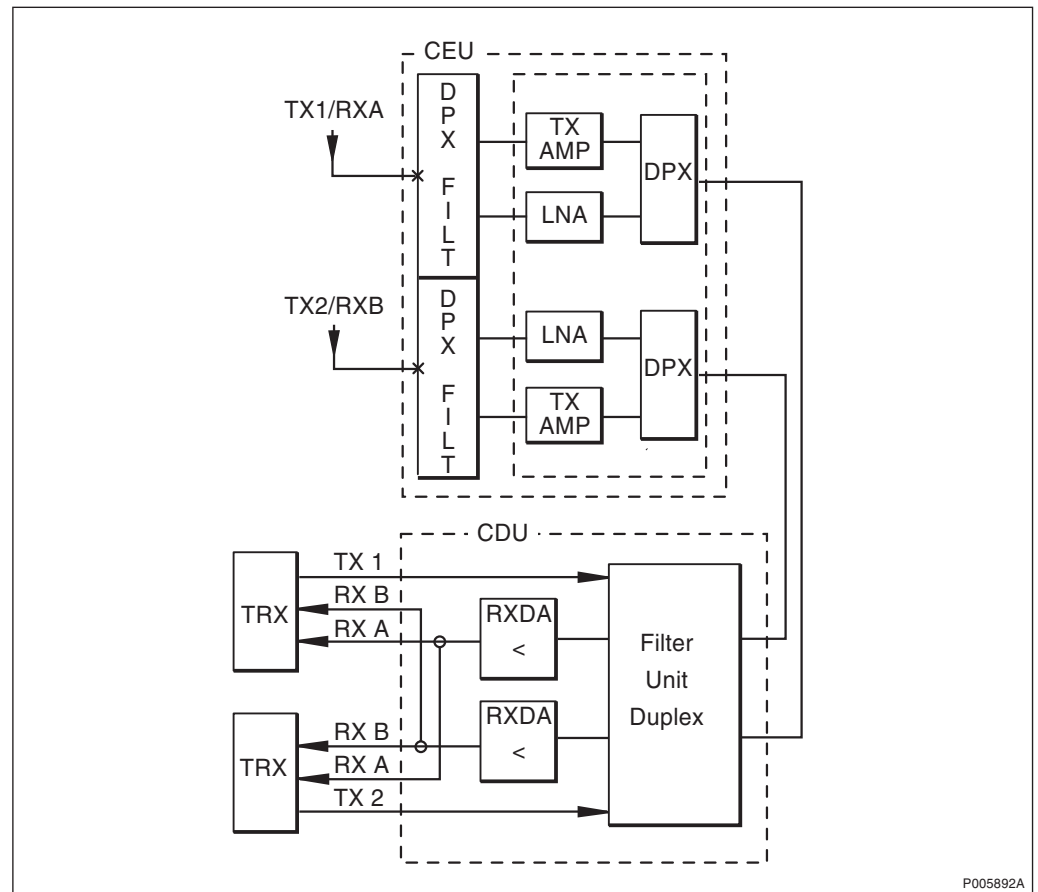

Figure 36 Basic configuration M9d_2.2\C

7.8.1 Characteristics M9d_2.2\C

| | |
|-----------------------|---------------|
| Frequency band | GSM 900 MHz |
| Max. no. of TRXs | 2 |
| No. of feeders | 2 |
| Antenna configuration | TX/RX + TX/RX |

7.8.2 Capacity M9d_2.2\C

The capacity is defined at the TX and RX reference points marked with X.

Capacity Radio Transmission: The output power with one TX to one TX/RX output is typical +41 dBm.

Capacity Radio Reception: The actual sensitivity level is -106 dBm, or better.

7.9 Basic Configuration GSM 900 MHz, M9d_2.2H

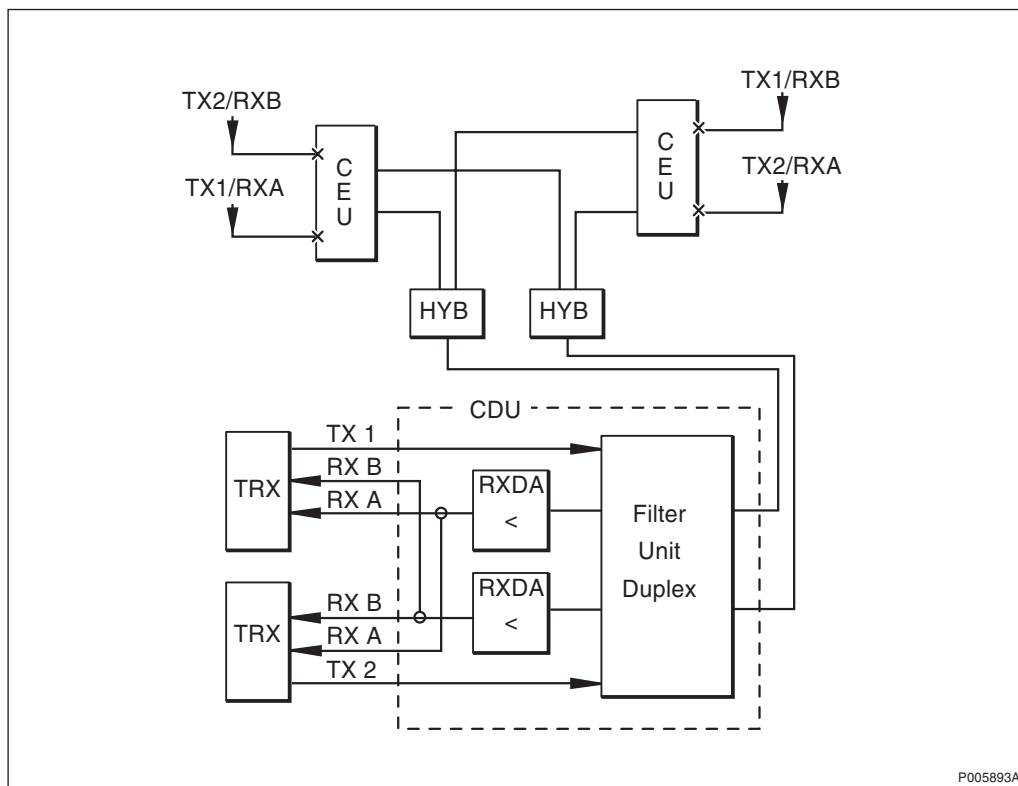

Figure 37 Basic configuration M9d_2.2\H

7.9.1 Characteristics M9d_2.2\H

| | |
|-----------------------|---------------------|
| Frequency band | GSM 900 MHz |
| Max. no. of TRXs | 2 |
| No. of feeders | 2 |
| Antenna configuration | 2 x (TX/RX + TX/RX) |

7.9.2 Capacity M9d_2.2\H

The capacity is defined at the TX and RX reference points marked with X.

Capacity Radio Transmission: The output power with one TX to one TX/RX output is typical +41 dBm.

Capacity Radio Reception: The actual sensitivity level is -103.5 dBm, or better.

7.10 Basic Configuration GSM 1800 MHz, M18d_2.2

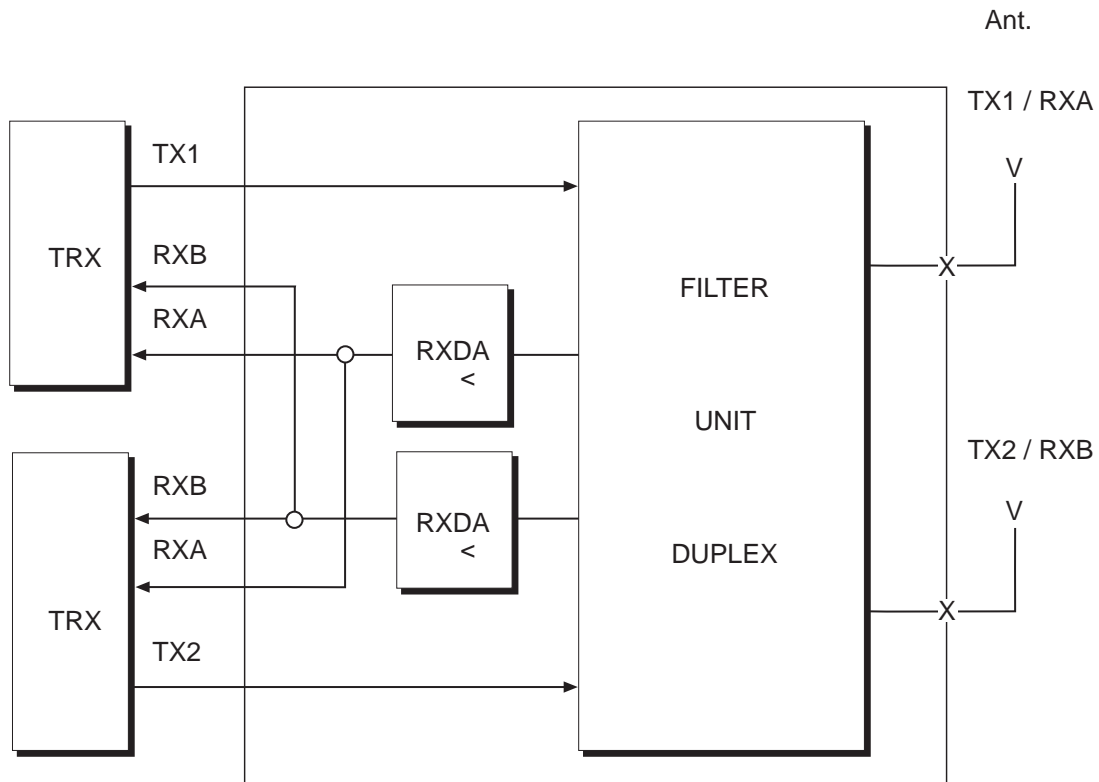

06_0348a

Figure 38 Basic configuration M18d_2.2

7.10.1 Characteristics M18d_2.2

| | |
|-----------------------|---------------|
| Max no. of TRXs | 2 |
| No. of feeders | 2 |
| No. of antennas | 2 |
| Antenna configuration | TX/RX + TX/RX |

7.10.2 Capacity M18d_2.2

The capacity is defined at the Tx and Rx reference points marked with X.

Capacity Radio Transmission: The output power with one TX to one TX/RX output is minimum +32 dBm.

The equivalent output power with TX diversity configured is minimum +35 dBm.

Capacity Radio Reception: The actual sensitivity level is -104 dBm, or better.

7.10.3 Capacity M18d_2.2 with Integrated Omnidirectional Antenna

The typical antenna gain for the omnidirectional antenna is +1 dBi for the GSM 1800 band.

Capacity Radio Transmission: The output power with one TX to one TX/RX output is minimum +32 dBm.

The maximum corresponding Effective Isotropic Radiated Power is thus minimum +33 dBm EIRP for the above antenna.

Capacity Radio Reception: The actual sensitivity level is -104 dBm, or better.

The corresponding sensitivity level with Omnidirectional antenna is -105 dBm, or better.

7.10.4 Capacity M18d_2.2 with Integrated Sector Antenna

The typical antenna gain for the sector antenna is +8.5 dBi for the GSM 1800 band.

Capacity Radio Transmission: The output power with one TX to one TX/RX output is minimum +32 dBm.

The maximum corresponding Effective Isotropic Radiated Power is thus minimum +40.5 dBm EIRP for the above antenna.

Capacity Radio Reception: The actual sensitivity level is -104 dBm, or better.

The corresponding sensitivity level with Sector antenna is -112.5 dBm, or better.

7.11 Basic Configuration GSM 1800 MHz, M18d_1.2

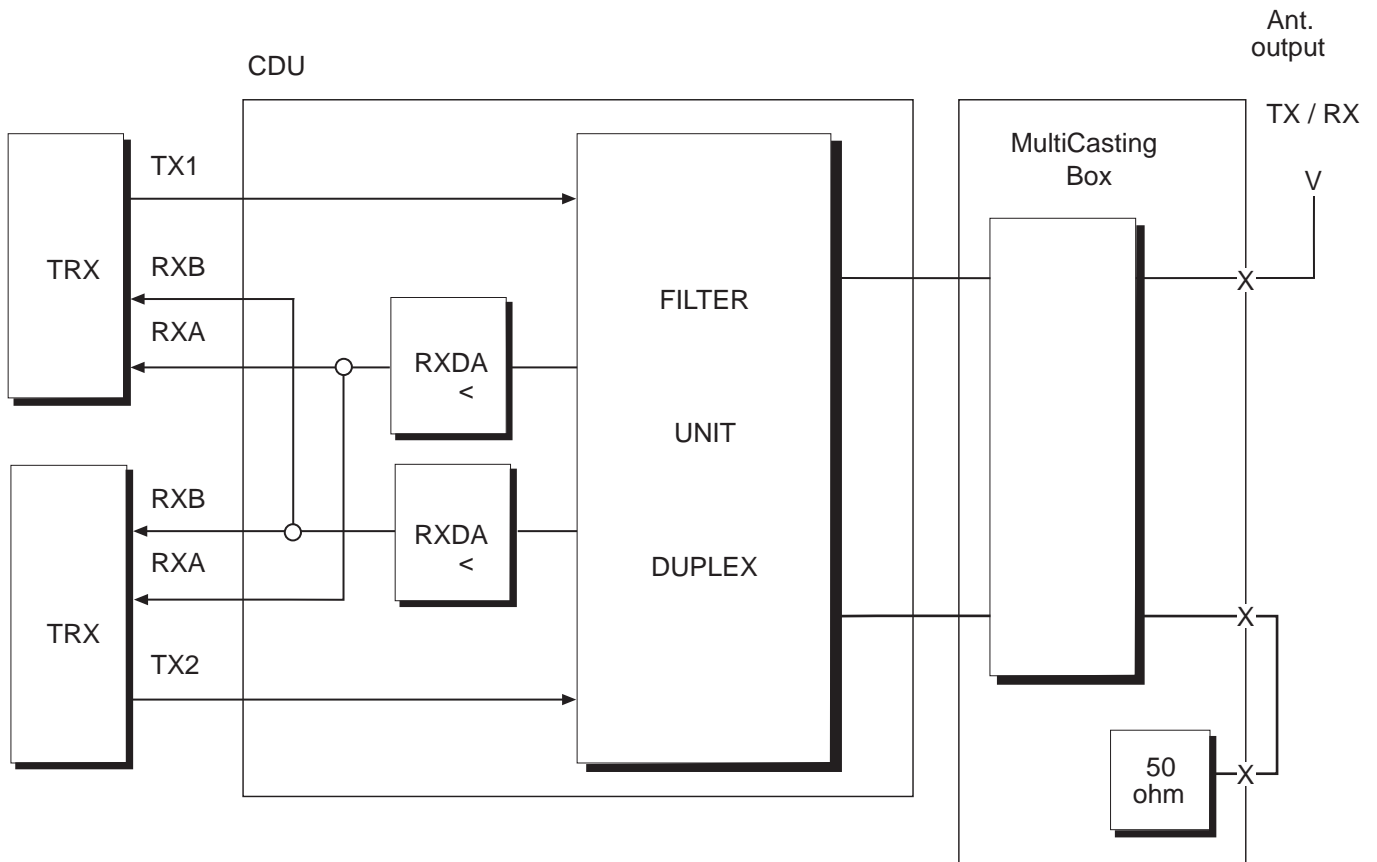

07_0348a

Figure 39 Basic configuration M18d_1.2

7.11.1 Characteristics M18d_1.2

| | |
|-----------------------------|----------------------------------|
| Max. no. of TRXs | 2 |
| No. of feeders | 1 |
| No. of antennas | 1 |
| Antenna configuration | TX/RX |
| Loss TRX-TX Reference point | Max. 4.5 dB in each output/input |
| Limitations | No RX diversity |

7.11.2 Capacity M18d_1.2 (with Multicasting Box)

The capacity is defined at the Tx and Rx reference points marked with X.

Capacity Radio Transmission: The output power from one TX to each TX/RX output/input is minimum +27.5 dBm.

Capacity Radio Reception: The actual sensitivity level is -99.5 dBm, or better.

7.12 Basic Configuration GSM 1800 MHz, M18d_2.2\A

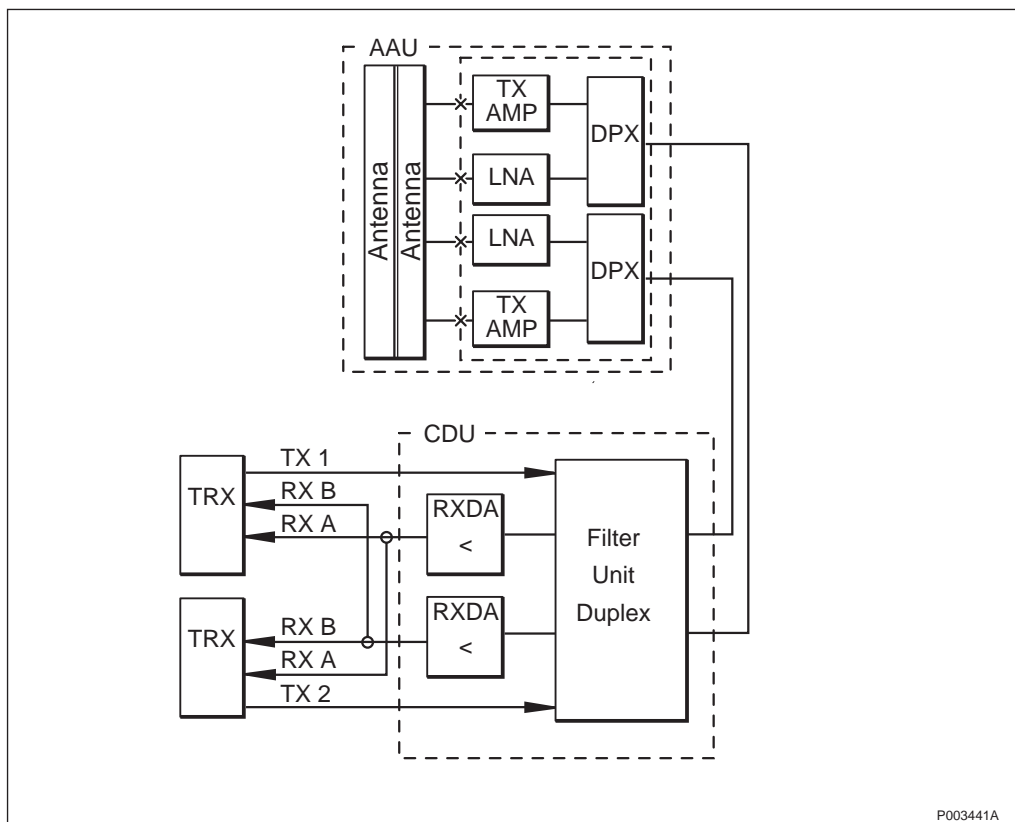

Figure 40 Basic configuration M18d_2.2\A

7.12.1 Characteristics M18d_2.2\A

| | |
|-----------------------|---------------|
| Max. no. of TRXs | 2 |
| No. of feeders | 2 |
| No. of antennas | 2 |
| Antenna configuration | TX/RX + TX/RX |

7.12.2 Capacity M18d_2.2\A

Capacity Radio Transmission: The output power from one TX to each TX/RX output/input is minimum +40 dBm.

The corresponding Effective Isotropic Radiated Power is minimum +55 dBm.

Capacity Radio Reception: The actual sensitivity level is -106 dBm, or better.

The corresponding sensitivity level with Active Antenna Aperture Gain is -123 dBm, or better.

7.13 Basic Configuration GSM 1800 MHz, M18d_2.2H

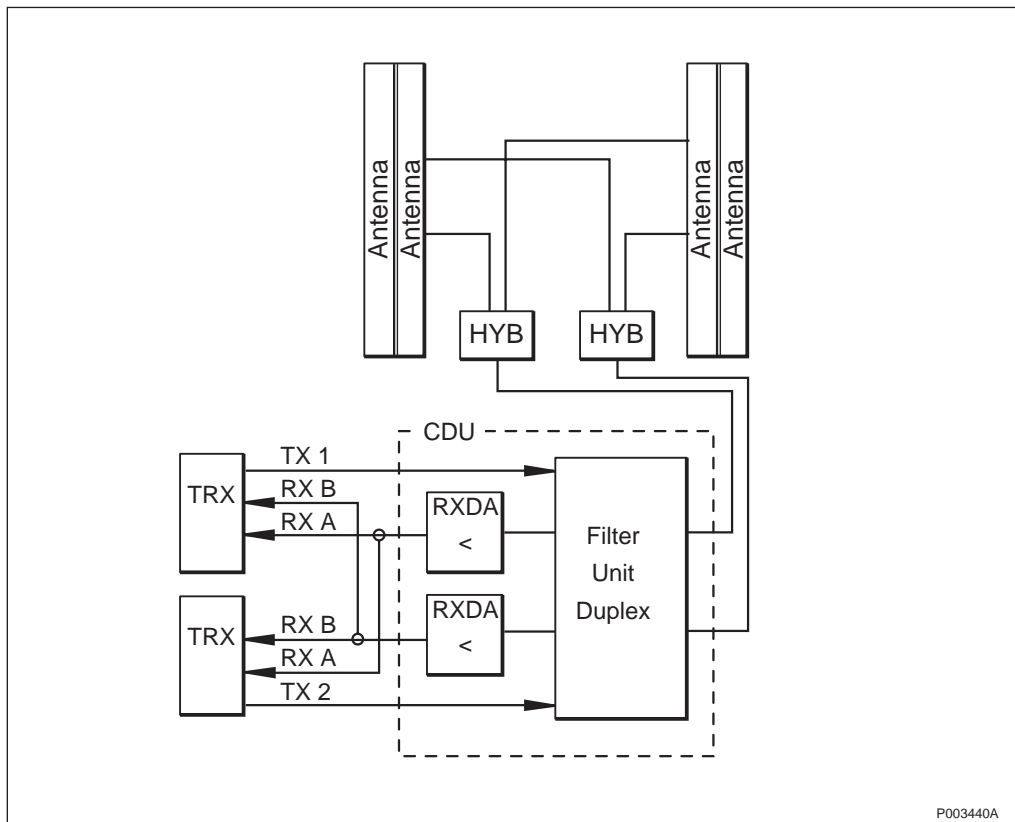

Figure 41 Basic configuration M18d_2.2\H

7.13.1 Characteristics M18d_2.2H

| | |
|-----------------------|-------------------|
| Max. no. of TRXs | 2 |
| No. of feeders | 2 |
| No. of antennas | 2 |
| Antenna configuration | 2x(TX/RX + TX/RX) |

7.13.2 Capacity M18d_2.2H

Capacity Radio Transmission: The output power from one TX to each TX/RX output/input is minimum +40 dBm.

The corresponding Effective Isotropic Radiated Power is minimum +55 dBm.

Capacity Radio Reception: The actual sensitivity level is -103.5 dBm, or better.

The corresponding sensitivity level with Active Antenna Aperture Gain is -120.5 dBm, or better.

7.14 Basic Configuration GSM 1900 MHz, M19d_2.2

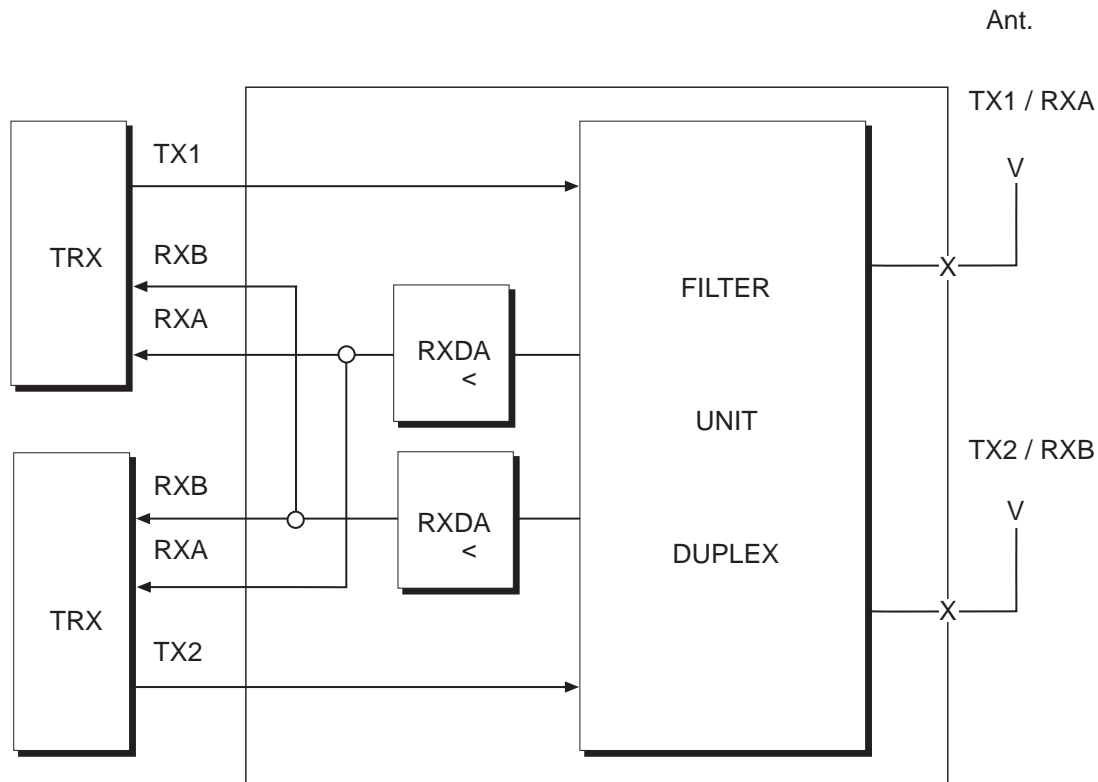

09_0348a

Figure 42 Basic configuration M19d_2.2

7.14.1 Characteristics M19d_2.2

| | |
|-----------------------|---------------|
| Max. no. of TRXs | 2 |
| No. of feeders | 2 |
| No. of antennas | 2 |
| Antenna configuration | TX/RX + TX/RX |

7.14.2 Capacity M19d_2.2

The capacity is defined at the Tx and Rx reference points marked with X.

Capacity Radio Transmission: The output power with one TX to one TX/RX output is minimum +32 dBm.

The equivalent output power with TX diversity configured is minimum +35 dBm.

Capacity Radio Reception: The actual sensitivity level is -104 dBm, or better.

7.14.3 Capacity M19d_2.2 with Integrated Omnidirectional Antenna

The typical antenna gain for the omnidirectional antenna is one dBi for the GSM 1900 band.

Capacity Radio Transmission: The output power with one TX to one TX/RX output is minimum +32 dBm.

The maximum corresponding Effective Isotropic Radiated Power is thus minimum +33 dBm EIRP for the above antenna.

Capacity Radio Reception: The actual sensitivity level is -104 dBm, or better.

The corresponding sensitivity level with Omnidirectional antenna is -105 dBm, or better.

7.14.4 Capacity M19d_2.2 with Integrated Sector Antenna

The typical antenna gain for the sector antenna is 9 dBi for the GSM 1900 band.

Capacity Radio Transmission: The output power with one TX to one TX/RX output is minimum +32 dBm.

The maximum corresponding Effective Isotropic Radiated Power is thus minimum +41 dBm EIRP for the above antenna.

Capacity Radio Reception: The actual sensitivity level is -104 dBm, or better.

The corresponding sensitivity level with Sector antenna is -113 dBm, or better.

7.15 Basic Configuration GSM 1900 MHz, M19d_1.2

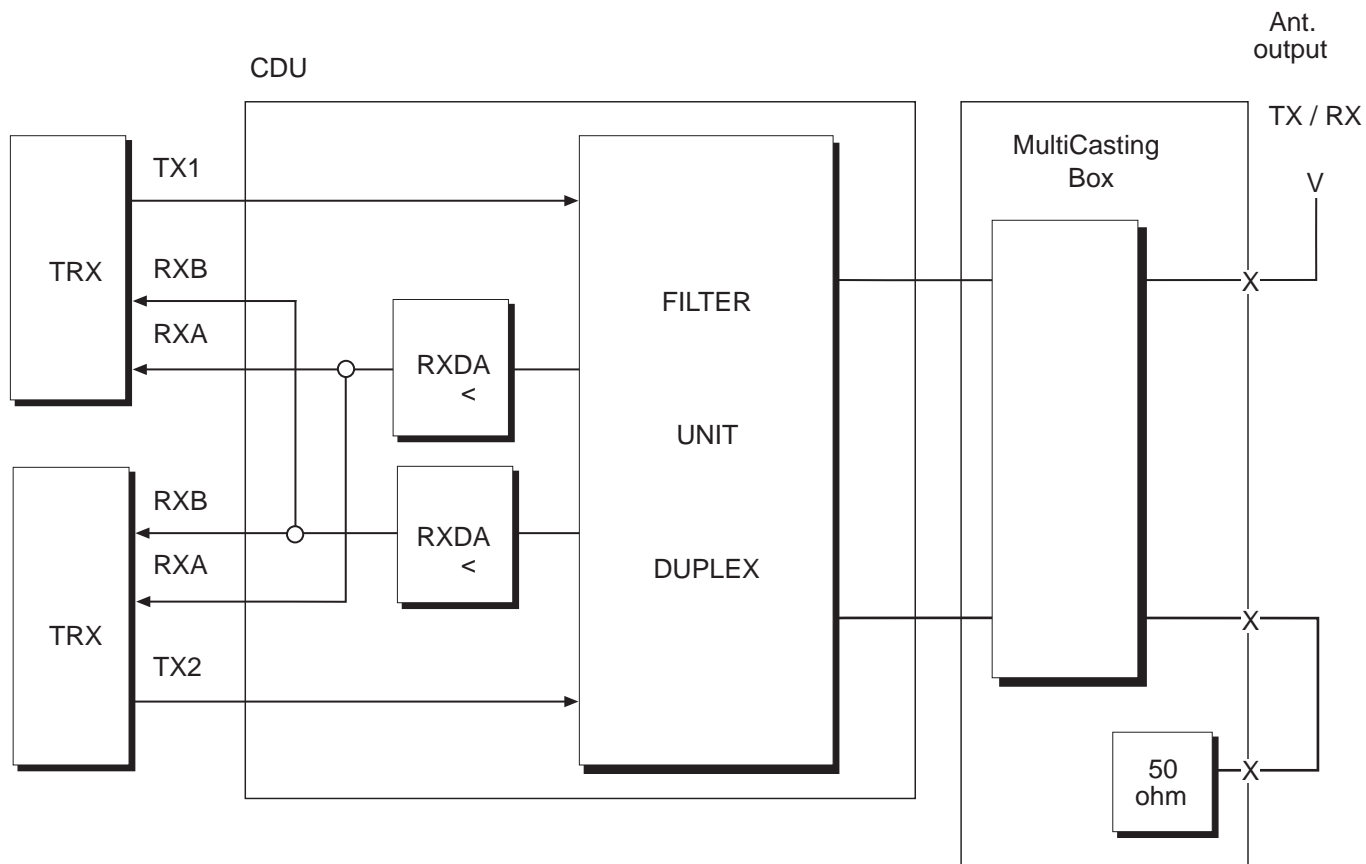

10_0348a

Figure 43 Basic configuration M19d_1.2

7.15.1 Characteristics M19d_1.2

| | |
|-----------------------------|----------------------------------|
| Max. no. of TRXs | 2 |
| No. of feeders | 1 |
| No. of antennas | 1 |
| Antenna configuration | TX/RX |
| Loss TRX-TX Reference point | Max. 4.5 dB in each output/input |
| Limitations | No RX diversity |

7.15.2 Capacity M19d_1.2 (with Multicasting Box)

The capacity is defined at the Tx and Rx reference points marked with X.

Capacity Radio Transmission: The output power from one TX to each TX/RX output/input is minimum +27.5 dBm.

Capacity Radio Reception: The actual sensitivity level is -99.5 dBm, or better.

7.16 Basic Configuration GSM 1900 MHz, M19d_2.2\A

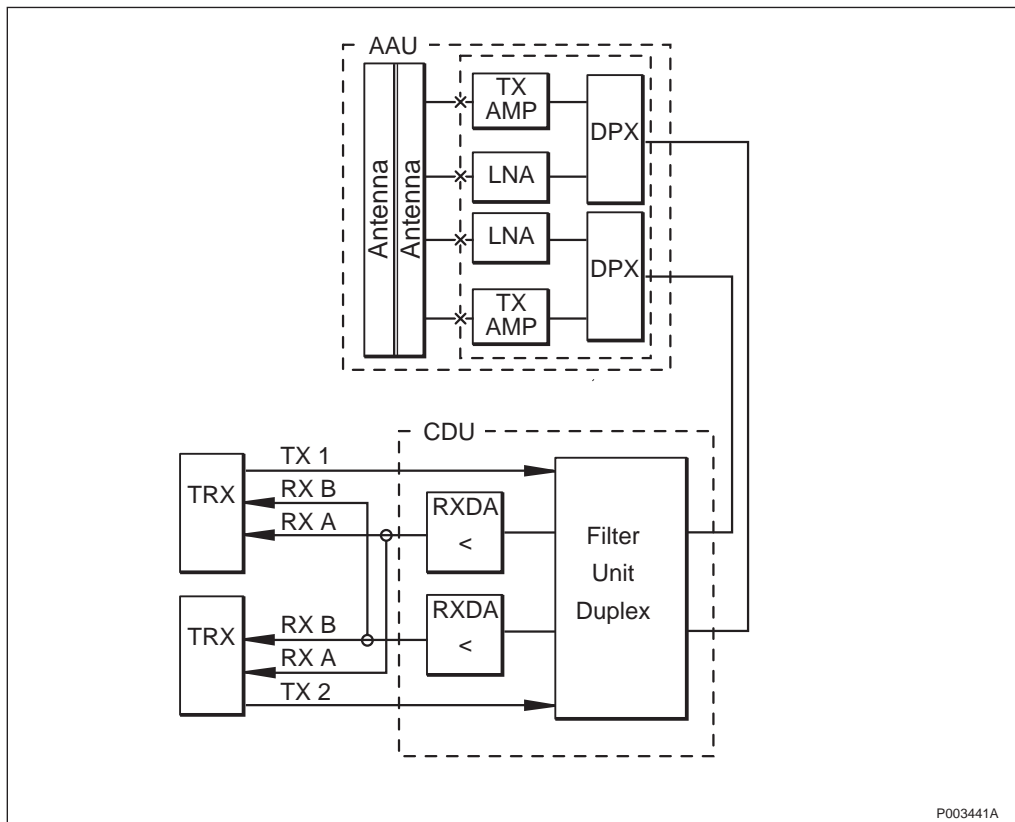

Figure 44 Basic configuration M19d_2.2\A

7.16.1 Characteristics M19d_2.2\A

| | |
|-----------------------|---------------|
| Max. no. of TRXs | 2 |
| No. of feeders | 2 |
| No. of antennas | 2 |
| Antenna configuration | TX/RX + TX/RX |

7.16.2 Capacity M19d_2.2\A

Capacity Radio Transmission: The output power from one TX to each TX/RX output/input is minimum +40 dBm.

The corresponding Effective Isotropic Radiated Power is minimum +59 dBm.

Capacity Radio Reception: The actual sensitivity level is -106 dBm, or better.

The corresponding sensitivity level with Active Antenna Aperture Gain is -127 dBm, or better.

7.17 Basic Configuration GSM 1900 MHz, M19d_2.2\H

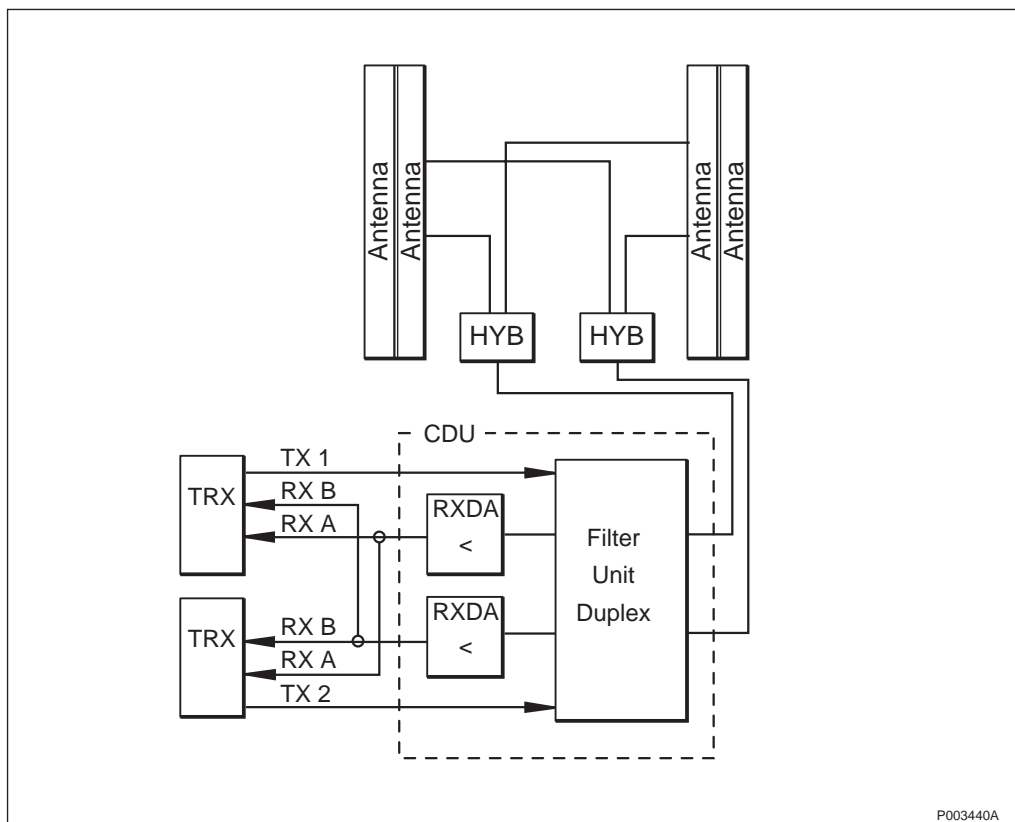

Figure 45 Basic configuration M19d_2.2\H

7.17.1 Characteristics M19d_2.2\H

| | |
|-----------------------|-------------------|
| Max. no. of TRXs | 2 |
| No. of feeders | 2 |
| No. of antennas | 2 |
| Antenna configuration | 2x(TX/RX + TX/RX) |

7.17.2 Capacity M19d_2.2\H

Capacity Radio Transmission: The output power from one TX to each TX/RX output/input is minimum +40 dBm.

The corresponding Effective Isotropic Radiated Power is minimum +59 dBm.

Capacity Radio Reception: The actual sensitivity level is -103.5 dBm, or better.

The corresponding sensitivity level with Active Antenna Aperture Gain is -124.5 dBm, or better.

8 Radio Configurations, RBS 2000 Small Indoor

8.1 References

/GSM 05. 05/

GSM Requirements 05. 05 phase 2+

8.2 Terminology

Antenna Reference Point (ARP) The ARP is defined as the point where the RX/TX antenna signal crosses the RBS border, that is, the connectors for the antenna connection.

Antenna System Is constituted by all RF transmission and reception antennas and directed to cover the same coverage area.

Basic Configuration The RBS has multicasting configuration only, that is, both TRXs are available at both antenna ports.

The basic configuration can be used in cascade (multidrop) configuration.

Site/Cell Configuration (SCC) Is a geographical concept that describes how an area around one radio base station site is divided into radio traffic areas.

8.2.1 Definition

The definition of the basic configuration type thus refers to CDU_type.

`<Basic_Config> ::= <X><F>d_<A>.<T>`

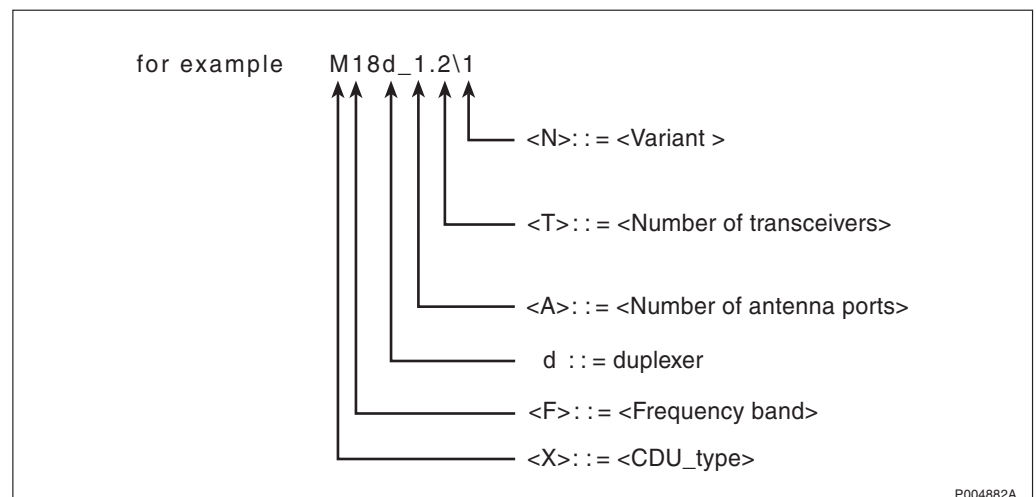

Figure 46

Type definitions:

<X> : : = <Basic CDU-type> : : = M
M: Micro/Small Indoor RBS

<F> : : = <Frequency Band> : : = 9/18
9: GSM 900 MHz
18: GSM 1800 MHz

<option> : : = d
d: Duplexer included in CDU

<A> : : = <No of antenna Ports> (1-2)

<T> : : = <No of Transceivers> (1-2)

<N> : : = \1 Variant

8.2.2 Site/Cell Configuration (SCC)

This is a geographical concept that describes how an area around one radio base station site is divided into radio traffic areas.

8.3 Frequency Bands

| | |
|----------|--|
| GSM 900 | Uplink: 890 - 915 MHz Downlink: 935 - 960 MHz |
| GSM 1800 | Uplink: 1710 - 1785 MHz Downlink: 1805 - 1880 MHz |

8.4 General

RBS Configurations are the designated expression for the RF parts integrated in the BTS. They consist of Transceivers and CDU.

The CDU functionality is:

- The output signal from the two transmitters is combined into the same antenna system, which is utilized as a TX/RX antenna.
- The received signal from the receive antenna system, which is utilized as a TX/RX antenna, is distributed to receivers belonging to the RBS.
- Multicasting functionality, see Section 8.5.3 on page 85.

8.5 Configurations

Small Indoor RBS TX power complies to:

| | |
|---------------------|----------|
| GSM:05. 05 Class M2 | GSM 900 |
| GSM:05. 05 Class M3 | GSM 1800 |

8.5.1 TX Output Power

The value given for the RBS output power for the different configurations below is the maximum RBS output power when the transmitter is set for maximum nominal power (P_o).

The RBS output power is measured at the ARP.

The tolerance for the RBS output power at the different settings is in compliance with /GSM900:05. 05:4.1.2/ for GSM 900 and GSM 1800.

Since the two transmitters are combined to one antenna, the transmitters must be operated with a minimum of 400 kHz separation between the centre frequency of adjacent carriers. This limitation is not caused by the combiner but the RBS itself.

The maximum nominal power, P_o , measured at ARP is:

nominal 19 dBm P-GSM 900

nominal 22 dBm GSM 1800

Nominal A-bis configuration power parameters for the Small Indoor RBS:

900 MHz: 07 - 19_(dec)

1800 MHz: 09 - 21_(dec)

Note: Only steps by 2 are configurable (from the highest value).

8.5.2 RX Description

The receiver system performance is defined in the ARP.

Actual sensitivity level is defined in and complying with the level where RBS meets the reference sensitivity performance defined in /GSM:05. 05:6.2/ for GSM 900/GSM 1800.

Radio Reception

The receiver sensitivity will be reduced when a third order intermodulation product, generated by the radio transmitters in the RBS, is received at the same ARFCN as the useful signal.

This occurs when the distance in frequency between two simultaneous transmitters is chosen in a way that a third order intermodulation product is generated at the same frequency as the operating frequency of one of the receivers in the RBS.

8.5.3 Multicasting Function

Small Indoor RBS has multicasting functionality only, that is, the two TX and RX signals are present at both antenna ports. This means that one or two antenna systems may be connected to the RBS. If only one antenna system is connected, the other one is terminated into a load of 50 Ω .

8.5.4 Isolation Values

The isolation requirements between two antenna systems belonging to the same RBS is reduced and shall at least be 15 dB, if the antennas do not have different polarization directions or different coverage area.

8.5.5 Limitations

RX-diversity is not supported.

TX-diversity is not supported.

Use of LNA or booster is not supported.

Frequency planning to avoid IM3-interference into its own receiver has to be done. See section Radio reception.

Small Indoor RBS shall not be colocated with or placed closer to a Macro RBS than 100 m, if free space propagation conditions exist.

8.5.6 Supported Basic Configurations

Small Indoor RBS

The following Basic Configurations are supported.

Table 19 Small Indoor RBS supported configurations

| No. of Cab. | Config/Band | SCC ¹⁾ | Allowed Config. ²⁾ | GSM 900 MHz | GSM 1800 MHz |
|-------------|-------------|-------------------|-------------------------------|-------------|--------------|
| 1 | M9d_1.2\1 | 1x2 | (0..2) | x | |
| 1 | M18d_1.2\1 | 1x2 | (0..2) | | x |

¹⁾ Max. number of cells times max. number of TRUs per cell

²⁾ Allowed number of TRUs in (cell 1) (cell 2) (cell 3), (Min..Max)

8.6 Basic Configuration GSM 900, M9d_1.2\1

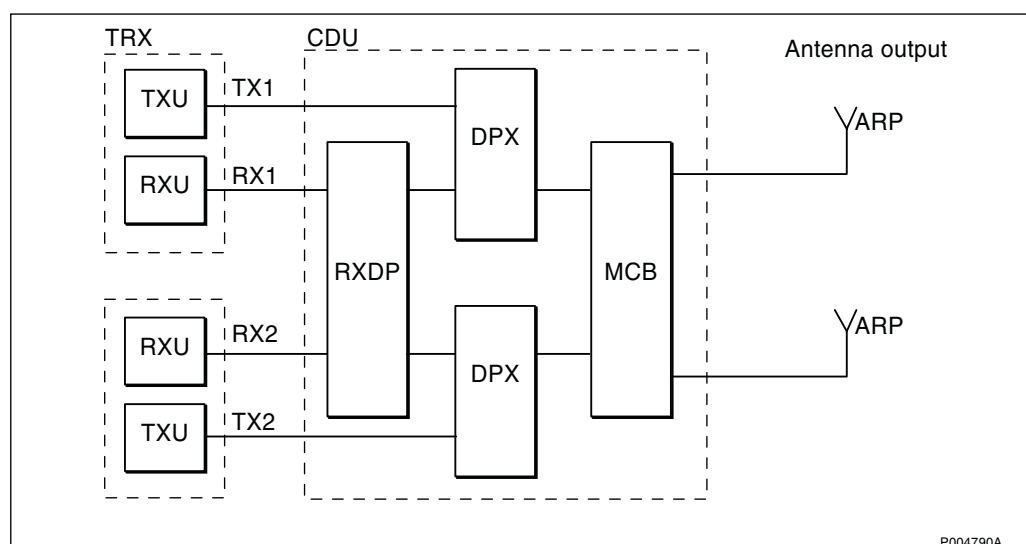

Figure 47 M9d_1.2\1

Note: One of the ARPs may be terminated in 50 Ω load.

8.6.1 Characteristics M9d_1.2\1

| | |
|------------------------|--------------------|
| Frequency Band: | GSM 900 |
| Max. no. of TRXs: | 2 |
| No. of feeders: | 1 or 2 |
| No. of antennas: | 1 or 2 |
| Antenna Configuration: | TX/RX in each port |
| Limitations: | No RX diversity |

8.6.2 Capacity M9d_1.2\1

The capacity is defined at the ARP.

Capacity Radio Transmission: The output power from one ARP output/ input is nominal +19 dBm.

Capacity Radio Reception: The actual sensitivity level is -98 dBm or better.

8.7 Basic Configuration GSM 1800, M18d_1.2\1

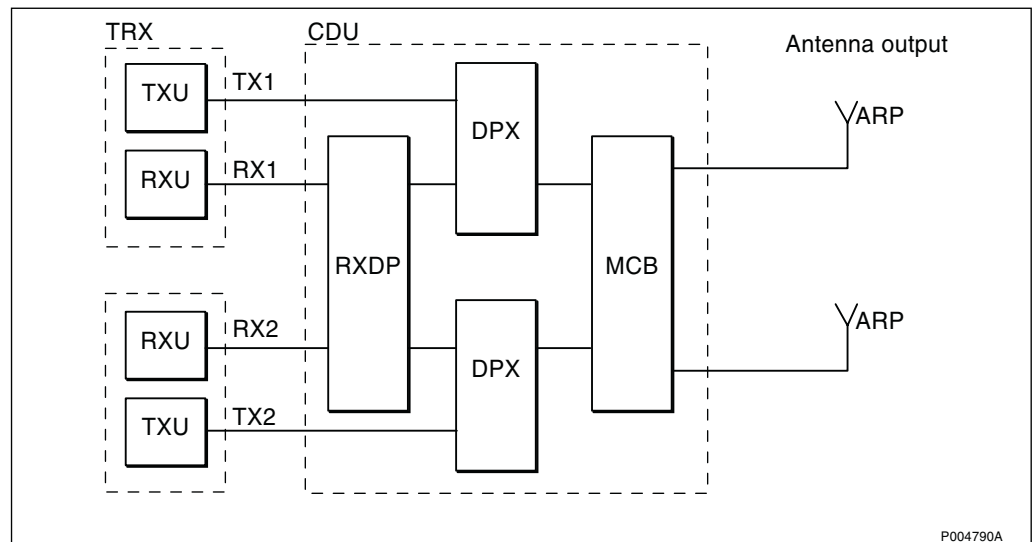

Figure 48 M18d_1.2\1

Note: One of the ARPs may be terminated in 50 Ω load.

8.7.1 Characteristics M18d_1.2\1

| | |
|-------------------|----------|
| Frequency Band: | GSM 1800 |
| Max. no. of TRXs: | 2 |
| No. of feeders: | 1 or 2 |

| | |
|------------------------|--------------------|
| No. of antennas: | 1 or 2 |
| Antenna Configuration: | TX/RX in each port |
| Limitations: | No RX diversity |

8.7.2 Capacity M18d_1.2\1

The capacity is defined at the ARP.

Capacity Radio Transmission: The output power from one ARP output/ input is nominal +22 dBm.

Capacity Radio Reception: The actual sensitivity level is -98 dBm or better.

9 Product Specification for RBS 2301

This chapter will describes the architecture, and specifies the characteristics and performance of the RBS 2301.

9.1 General

The RBS 2301 satisfies the need for "hot spot" capacity in small areas, such as part of a city centre or a shopping mall, as well as "fill in" coverage.

The main focus with this product is to reduce site cost and make it easier for operators to find sites, which will ensure operator profitability of a micro cell network.

To be able to support the idea of a small RBS that can be located almost anywhere, some functional limitations has been made:

- Low output power.
- No antenna supervision (VSWR).
- No RF cable supervision.
- No expansion possibility.

The RBS is designed to fulfil applicable parts of the GSM and JTC specifications.

The weather-proof cabinet and design make it ideal for installation indoor, outdoor, on poles, walls or mast.

Integral antennas can be ordered as omnidirectional or sector antennas, except from this there is always a possibility to connect external antennas.

The base colour of the RBS is grey (NCS S2502-R), but there is a possibility to order the front sun-shields in different colours, which will make the RBS more discrete.

The RBS is built up by the following main physical units: Mounting Base, Cabinet, Antennas and Sun-shield. This will support a routine of installing the Mounting Base prior to the Cabinet arrival.

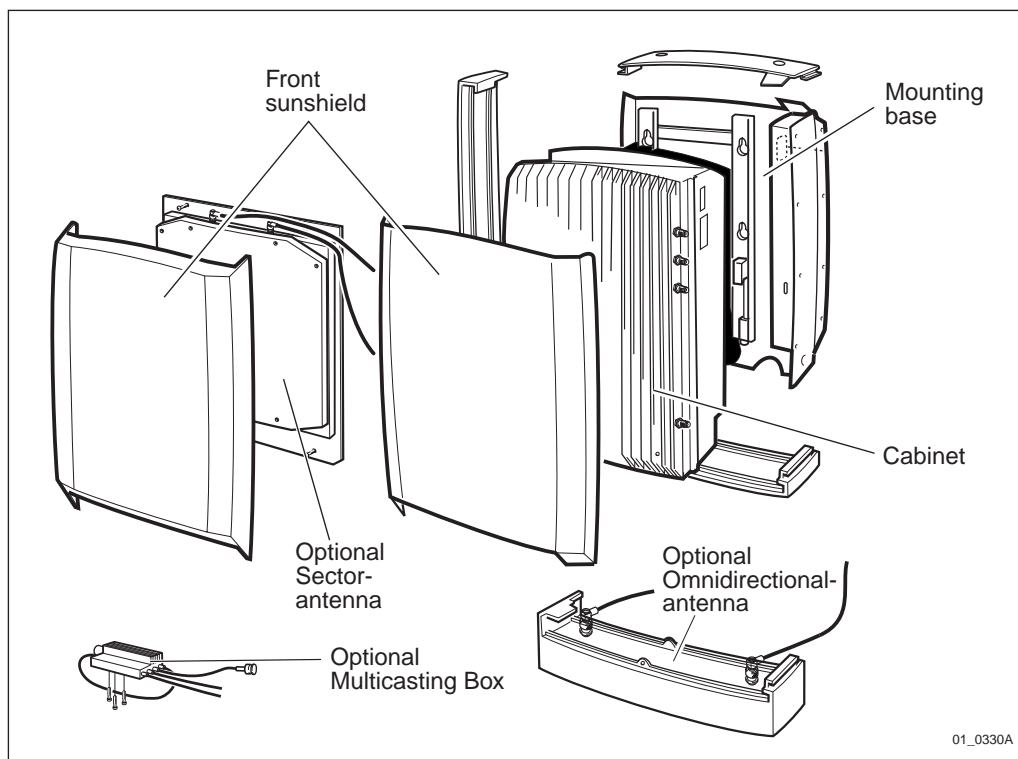

Figure 49 Main physical units

The prime technical concerns have been to implement a RBS that:

- has a small size (volume and weight), and an appearance suitable for a discrete installation ("landlord friendly").
- has high channel capacity, two transceivers giving total of 15 traffic channels if configured to one cell, or 7 + 7 traffic channels if configured to two cells.
- is characterized by low need for preventive maintenance.
- has high MTBF.
- has versions for the different system standards GSM 900, GSM 1800 and GSM 1900.
- includes all functions needed for a complete installation of a radio base station, including standard interface G703 E1 or T1 (DS1) to transmission network, AC mains power, battery backup and antennas.
- support Linear Cascade connection on the transmission interface.
- is possible to install by one person.
- can be installed by ordinary skilled installation personnel.

9.2 Product Architecture

9.2.1 Hardware Units

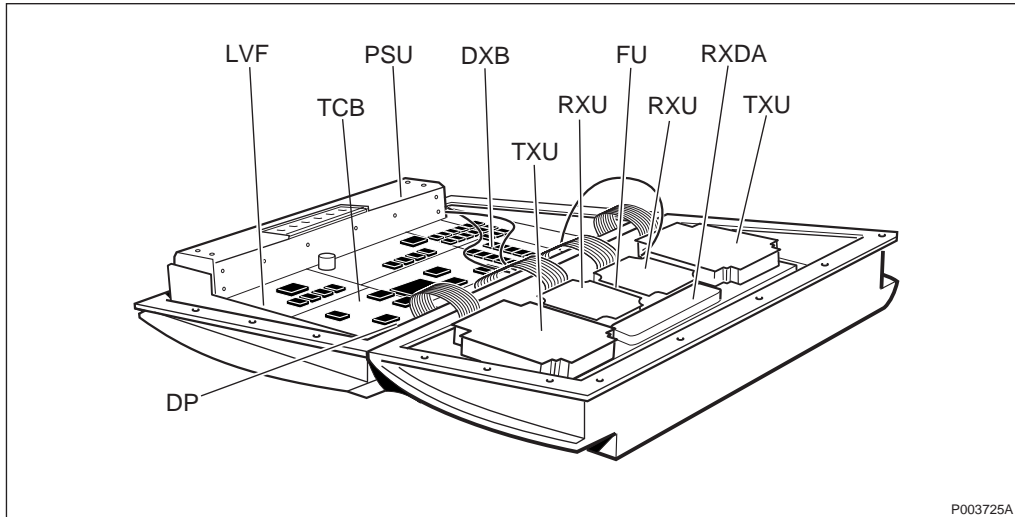
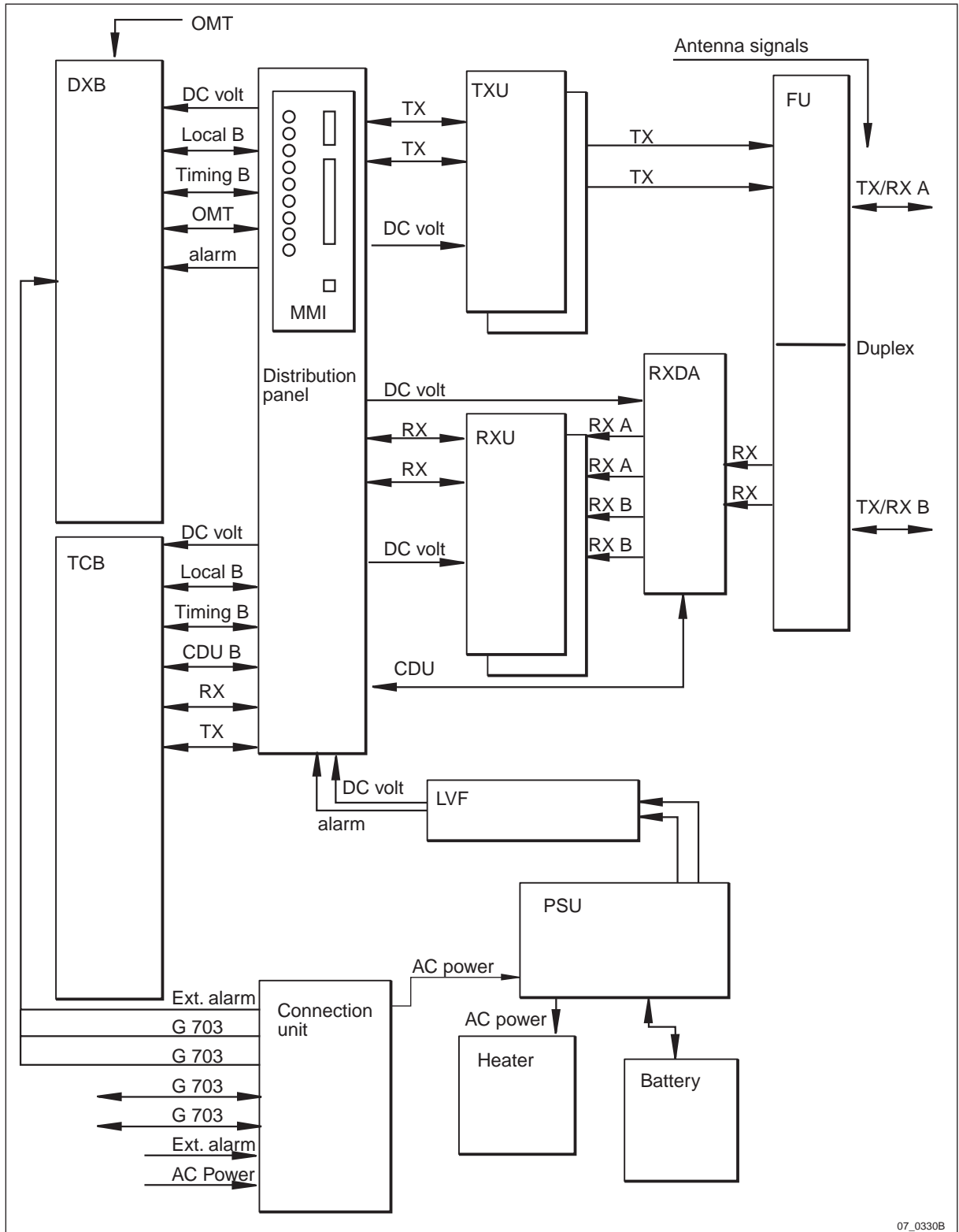

Figure 50 Hardware units in cabinet

| | |
|------|---|
| DXB | <p>Distribution Switching Board</p> <p>The DXB (1 per RBS) is the central control unit for the RBS and supports the transmission interface.</p> |
| OMT | <p>Operation and Maintenance Terminal</p> <p>The OMT is a PC based terminal used during installation and maintenance.</p> |
| TCB | <p>Transceiver Control Board</p> <p>The TCB (2 per RBS) includes equipment related to signal processing for up to two radio carriers.</p> |
| TXU | <p>Transmitter Unit</p> <p>The TXU (2 per RBS) contains equipment for transmission on one radio carrier.</p> |
| RXU | <p>Receiver Unit</p> <p>The RXU (2 per RBS) contains equipment for reception on one radio carrier.</p> |
| RXDA | <p>Receiver Divider Amplifier</p> <p>The RXDA (1 per RBS) contains equipment for low noise amplification of the received radio carrier(s) and dividing each incoming RX into two output carriers.</p> |
| FU | <p>Filtering Unit</p> |

| | |
|--------------------|---|
| | <p>The FU (1 per RBS) is the interface between the transmitters, receivers and the antenna system.</p> |
| LVF | <p>Low Voltage Filter</p> <p>The LVF contains components for voltage filtering.</p> |
| PSU | <p>Power Supply Unit</p> <p>The PSU (1 per RBS), which rectifies the incoming AC mains to regulated DC voltages, controls and supervises the battery and supervises the temperatures inside the cabinet.</p> |
| Climate Equipment | <p>Heater to heat the RBS at low temperature.</p> |
| Battery | <p>The battery is an internal entity and is replaceable without disturbing traffic handling.</p> |
| Connection Unit | <p>The connection unit contains components for lightning and EMC protection. It also includes fuses, AC mains and battery switch as well as plinths for the external interfaces except for antenna feeders.</p> |
| Distribution Plane | <p>The distribution plane interfaces the DXB, the TCB, the TXUs, the RXUs and the PSU. It also contains the buttons and indicators for the RBS.</p> |



07_0330B

Figure 51 Overview

9.3 Configuration

9.3.1 Options

The RBS is a flexible product which can be ordered according to different customer needs.

The following options are available:

- Mast mounting fixture
- Internal high precision oscillator
- Integral antennas
- Multicasting box

Multicasting functionality: One feeder system which can be used for a distributed antenna system.

Sun-Shield

The following optional colours are available for the front sun-shield.

NCS S3010-G80Y (Olive green)

NCS S2020-R70B (Sky blue)

NCS S2030-Y40R (Brick red)

NCS S2040-Y20R (Ochre)

NCS S1010-Y20R (Light yellow)

According to NCS standard.

9.3.2 Variants

Configurations

The RBS will support the following basic configuration alternatives:

Table 20

| GSM 900 | GSM 1800 | GSM 1900 |
|---------|----------|----------|
| M9d_1.2 | M18d_1.2 | M19d_1.2 |
| M9d_2.2 | M18d_2.2 | M19d_2.2 |

The performance for each configuration is described in ref. /GS-Config/.

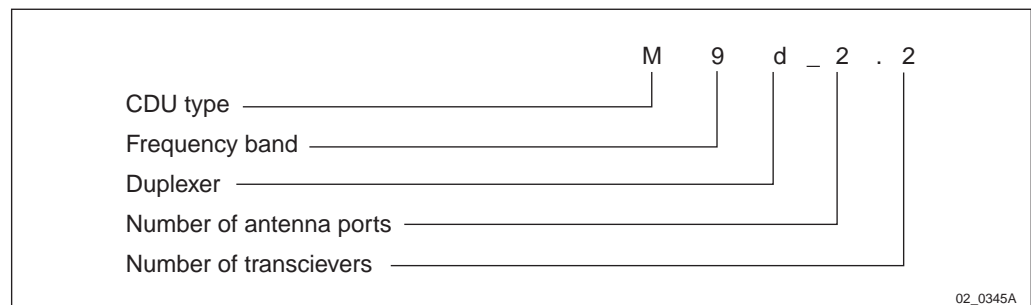

Figure 52 How to read the code

Table 21

| Object | RBS Variants |
|-----------------------------|--|
| Traffical capacity | 2 TRX |
| Encryption | A5/1, A5/2 |
| Transport Network Interface | 1.5 Mbit/s, 100 Ohm 2.0 Mbit/s, 75 Ohm 2.0 Mbit/s, 120 Ohm |
| Filter | Duplex |

Integral Antennas

The following selection are available: Omnidirectional or Sector.

Extended Temperature Range with Optional Fan Unit

It is possible to extend the temperature range to 55 (45 + 10) degrees Celsius with the optional Fan unit, placed on top of a site installed RBS 2301/2302.

The Fan unit:

- must be connected to 115 or 230 mains supply voltage. The power consumption is below 20 VA.
- consists of three fans and one fan controller box. One binary alarm (from the fan controller box) is connected to the RBS 2301/2302 external alarm.
- is considered as one replaceable unit.

The external AC-cable shall be provided by the customer and the AC must be possible to break during installation/maintenance.

9.4 Combinations

Possible combinations are described in Ordering Information.

9.5 Transmission Modes

The RBS 2301 can be configured for linear cascade mode and stand alone mode. The configuration is performed by means of the OMT.

When used as stand alone, PCM port A shall be connected towards the BSC. In this mode, PCM port B cannot be used.

When used in linear cascade mode (multidrop), the RBSs are connected so that each RBS uses its port A towards the BSC and port B towards the next RBS. That RBS is connected in the same way with port A towards the previous RBS (and indirectly the BSC) and port B towards the next RBS, and so on.

Only RBSs that support multidrop can be included in the multidrop chain. Figure 53 on page 96 shows a multidrop chain with three RBSs.

The multidrop function handles 64 kbit/s timeslots only. All RBSs have dedicated timeslots.

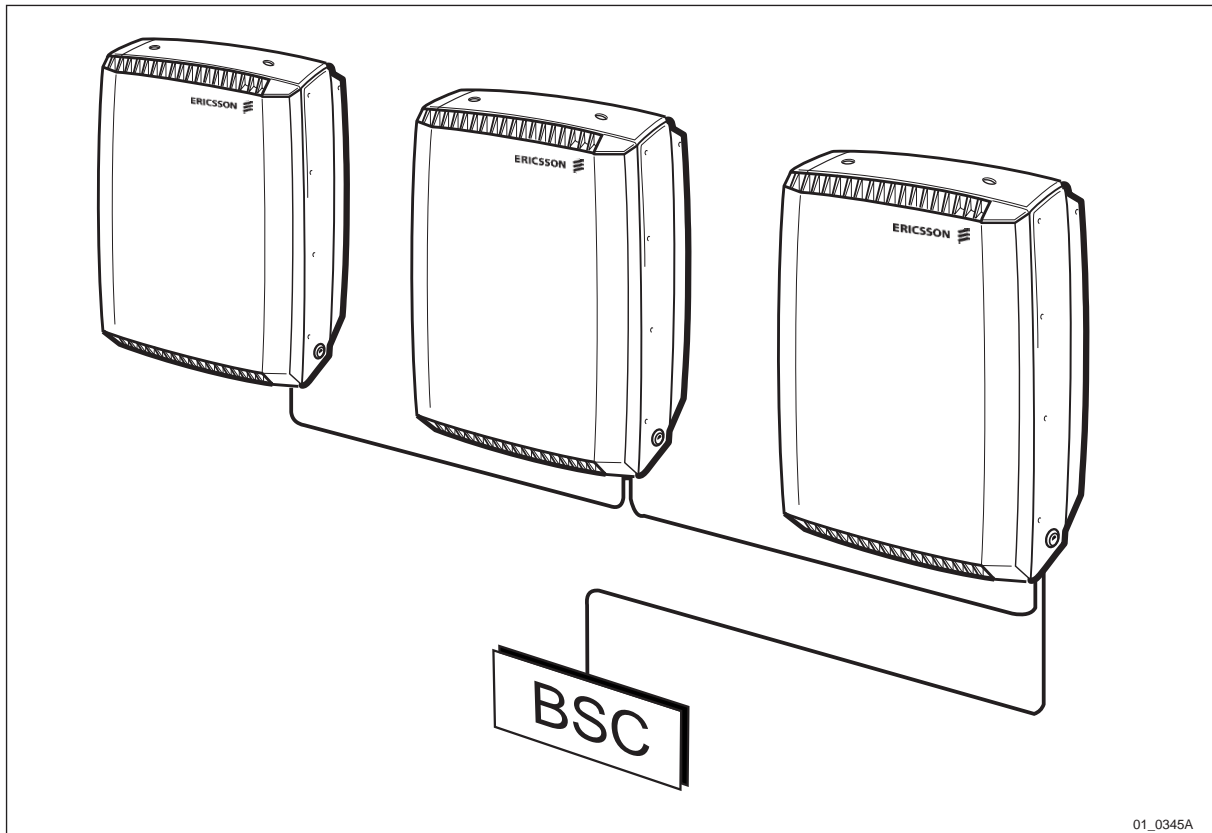

Figure 53 Multidrop chain

9.6 Interface and Connection

9.6.1 External Connections

AC Mains

Type of connections: Screw terminal for 4 times max. 2.5 mm²
 Cable gland capacity: 1 times Ø 14 mm

External Alarms

Type of connections: Screw terminal for 8 times max. 1.5 mm²
 Cable gland capacity: 1 times Ø 10 mm
 Number of alarms: 4

Antenna Connectors

Type of connectors: TNC (receptacle) female

Note: When using integral antennas, Cables and connectors are included, these connection are placed on the cabinet.

Transmission

- Type of connections:
alternative
1. Coax Cable 75 Ohm
 2. 100/120 Ohm

Earthing

Central earth terminal point M8 thread.

9.6.2 Internal Connections**OMT**

- Type of connections: 9 pin D-sub (receptacle) female

9.6.3 Test Interface

The RBS is equipped with test ports for connection of external instruments. The following signal are available at test ports:

13 MHz Reference

- Type of connectors: SMB connector (receptacle) male

9.6.4 Operator Interface

When opening the Mounting Base there is an MMI area available containing the operational interface which includes the LEDs and buttons listed below.

Indicators (LEDs)

| | |
|------------------|---------------------------------------|
| Fault | One or more faults, equals BS fault |
| Operational | At least one TRX operational |
| Local mode | RBS in local mode |
| Reduced capacity | One of two TRXs operational |
| Test TRX1 | Result from TRX1 test operation |
| Test TRX2 | Result from TRX2 test operation |
| AC Power on | AC Power is switched on to RBS |
| Battery fault | Lowbattery DC voltage, battery absent |
| External alarm | One or more external alarm active |

Buttons

- CPU reset
Local/remote mode

Test Operation initiation

Switches

Battery

AC Mains

9.7 Product Requirements

9.7.1 Appearance

Ericsson products are designed to appear as one physical unit, inconspicuous, pleasant and good-looking. The standard colour of the RBS is grey.

The front cover of the RBS which is designed as a sun-shield may be ordered in different colours to make the RBS even more inconspicuous.

There is an optional integrated antenna system which will support the idea that the RBS and antenna site are the same.

9.7.2 Mechanical Structure

Replaceable Units

The RBS consists of the following replaceable units:

- Cabinet
- Mounting base
- Integral antennas
- Sun-shield
- Batteries
- Connection unit
- Wall fixture
- Mast/pole fixture

Labels

All signs are placed to fulfil the requirements behind the purpose and reason for the signs. And all signs that are needed for identification of the product and its compliance are readable without disturbing the RBS function.

9.7.3 Dimension and Weight

Volume

The total volume of a complete RBS site without cabling, 33 l.

Size

(HxWxD): 535x408x160 mm (without integral antennas).

(HxWxD): 535x408x210 mm (with Sector Antenna).

(HxWxD): 607x408x160 mm (with Omnidirectional Antenna).

Weight

The total weight is the sum of the following handling units:

| | |
|----------------|--------------------------------|
| Cabinet | 18 kg (incl. internal battery) |
| Mounting Base | 6.5 kg (incl. sun-shield) |
| Wall bracket | 3 kg |
| Omni Antenna | 0.5 kg |
| Sector Antenna | 2 kg |
| <hr/> | |
| Total Weight | 30 kg |

(A temporary lifting device can be attached during installation.)

9.7.4 Hardware Characteristics**Acoustical Noise**

The RBS will not contribute to the acoustical noise in the surroundings.

Vandal Resistance

The RBS will appear as vandal resistant and unauthorized intrusion will not be possible without damaging the unit.

Package Material

The package material is recyclable.

Handling Robustness

The RBS main cabinet is designed to accept intermediate placing on the ground during installation and maintenance work.

9.7.5 Environment**Operation**

The RBS is designed to endure the requirement for "outdoor mast mounted equipment".

Temperature range: -33° - +45°C

For details see: Section "Environmental Capabilities RBS 2301"

Solar Radiation

The RBS is designed to withstand the additional heat from solar radiation in its specified environment.

Transport

The RBS is designed to endure the requirement for transport.

Temperature range: -40°C - +70°C

For details see: Section "Environmental Capabilities RBS 2301"

Storage

The RBS is designed to endure the requirement for storage.

Temperature range: -25°C - +55°C

For details see: Section "Environmental Capabilities RBS 2301"

Handling

The RBS is designed to endure the requirement for Handling. Handling of RBS parts during installation and maintenance.

Temperature range: -40°C - +70°C

For details see: Section "Environmental Capabilities RBS 2301"

In addition to this requirement the RBS 2301 will endure topple. Minor damage of the cabinet, that is, a broken corner of a cooling fin at topple will not disturb the function of the RBS.

9.7.6 Climate Protection

Climate Protection Principle

The climate protection maintains the internal temperature within allowed range for the units in the RBS.

The climate protection of the RBS is handled by a combination of:

- Natural convection with the help of cooling fins
- Conductional heating

Heating Capacity

The system have the capacity to heat the RBS from:

- -33 °C to starting conditions within 30 minutes
- -15 °C to starting conditions within 15 minutes

If the environmental conditions are: no wind or accumulated ice or snow on the RBS.

Ingression

The RBS fulfil the IP-55 requirements according to the standard IEC 529.

9.7.7 Power Supply**Supply Voltage**

The RBS can be connected to mains supply voltage with Nominal:

| | | |
|-------------------|-------|-------------|
| 200 - 250 VAC | ±10 % | 50 Hz ±10 % |
| 100 - 127 VAC | ±10 % | 60 Hz ± 8 % |
| 200/100 - 240/120 | ±10 % | 60 Hz ± 8 % |

The RBS will support installation with:

Single-phase (two-wire; earthed end of phase).

Single-phase (three-wire; earthed mid point).

Single-phase (three-wire; separate PE and N conductor).

According to TN, TT and IT power system.

Power Consumption

Normal operation, both TRXs transmitting on full output power.
(at 230 V nominal mains supply) 150 VA

Maximum power consumption: 500 VA (only with activated heater)

Battery Backup

The RBS will survive interruptions on mains supply during at least 3 minutes. The RBS will maintain full performance during the backup time if the battery is fully charged. The battery will be recharged to at least 80 % of its capacity within 15 hours.

For longer backup time an external UPS may be used.

9.7.8 Type Approval**Type Approval Standard**

The product fulfils the required type approvals from: GSM 11.20 or GSM 11.21 standard JTC standard FCC rules and regulations. According to requirements in Section Product Safety Requirements RBS 2000.

9.7.9 Dependability

Preventive Maintenance

These preventive maintenance conditions must be fulfilled to guarantee the availability of the RBS.

| Action | Interval |
|--|-----------|
| Change of battery | < 5 years |
| Change of lightning protection equipment | <10 years |
| Calibration of "optional" synchronisation oscillator | < 3 years |

9.7.10 Installation

A quick and easy installation procedure is provided. If the installation preconditions are met, the RBS can be installed in less than 30 minutes. A minimum of tools and instruments are required when installing an RBS.

Preconditions

- The initiation of the BSC is prepared
- The transport network available¹⁾ at the site
- Mains power available at site
- Preinstalled antennas and feeders are available¹⁾
- Wall fixture preinstalled
- Friendly geographic location and environment (means higher than -10 °C, no precipitation and easy access to the site)

¹⁾ "available" means: accessible and with specified function.

Installation Scenario

To support the idea of a quick and smooth installation scenario, the RBS installation work can be divided in to two steps:

- Preinstallation. Installation of the Mounting Base, antennas and all necessary cabling (AC mains, transmission and alarms).
- Installation and Commissioning. Installation of the Cabinet includes all parts according to customer ordering.

However the installation is possible to carry out in one site visit.

The manual operations at installation are few and easy, which is also valid when connecting external cables.

There is no need for an OMT on site during installation work.

Site Installation Requirement

When installing more than one RBS at the same site, the RBSs must be separated. The separation is necessary because of antenna isolation requirements and to provide sufficient working space.

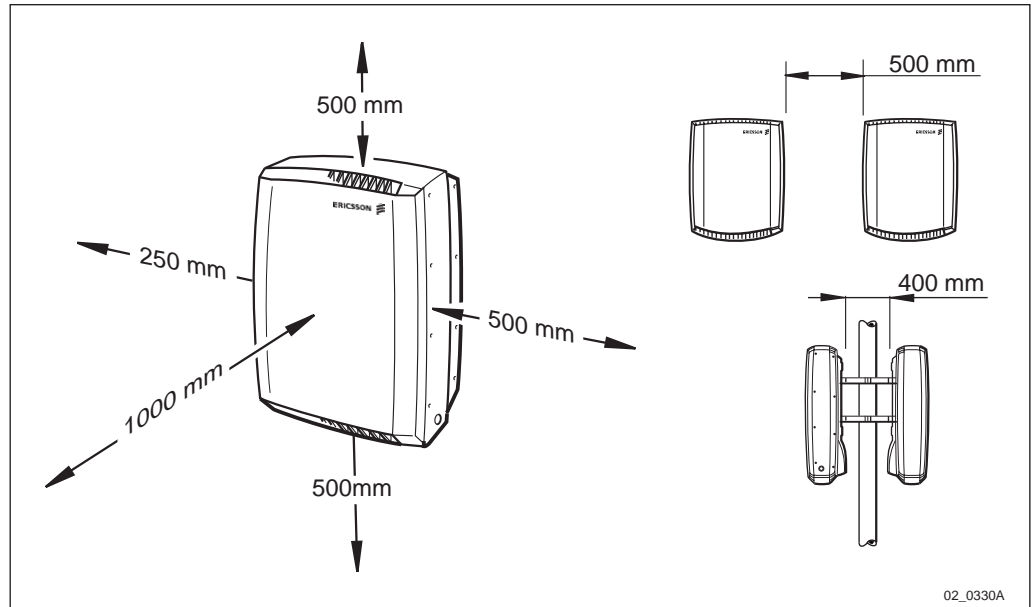

Figure 54 Required separation between RBSs

- Min separation 0.5 m side by side
- Min separation 0.5 m above/below
- Min separation 0.4 m back to back

Free space is required around the RBS for installation and maintenance. For a simple installation, following distances are recommended:

- Front: 1.0 m
- Side: 0.25 m
- Top: 0.5 m
- Bottom: 0.5 m

This page is intentionally left blank

10 Product Specification for RBS 2302

This chapter describes the architecture of the RBS 2302 and specifies its the characteristics and performance.

10.1 Terminology

| | |
|-----------------|--|
| TN Power System | TN Power System is a power distribution system having one point directly earthed. The exposed conductive parts of the installation are connected to that point by protective earth connectors. |
| TT Power System | TT Power System is a power distribution system having one point directly earthed. The exposed conductive parts of the installation are connected to earth electrodes electrically independent of the earth electrodes of the power system. |
| IT Power System | IT Power System is a power distribution system having no direct connection to earth. The exposed conductive parts of the electrical installation are earthed. |
| MAXITE™ | MAXITE™ is a complete package for a radio site for GSM 900, 1800 and 1900. MAXITE consists of RBS 2302, a Power and Battery Cabinet and Active Antenna Unit for GSM 1800/1900, and Coverage Extension Unit plus Passive Antenna for GSM 900. |

10.2 General

The RBS 2302 satisfies the need for "hot spot" capacity in small areas, such as part of a city centre or a shopping mall, as well as "fill in" coverage.

The main focus with this product is to reduce site cost and make it easier for operators to find sites, which will ensure operator profitability of a micro cell network.

The RBS 2302 can be expanded with up to six transceivers by adding extra RBS 2302 cabinet to a site.

Note: 4 TRX and 6 TRX are only valid for R7 and later.

To be able to support the idea of a small RBS that can be located almost anywhere, some functional limitations has been made:

- Low output power, for non-MAXITE configurations.
- No antenna supervision.
- No RF cable supervision.

The weather-proof cabinet and design make it ideal for installation indoor, outdoor, on poles, walls or masts.

Integral antennas can be ordered as omni or sector antennas. Apart from this there is always a possibility to connect external antennas.

A multicasting box is provided to make it possible to combine the antenna signals from two TRXs into one antenna feeder.

When extra coverage is needed, the RBS 2302 may be connected to active antennas to form a MAXITE configuration.

For sites located in places with extreme heat an active cooling device may be provided as an option.

An extended OMT port (a permanent cable from the RBS to a more convenient place) is provided as an option.

The base colour of the RBS is grey (NCS S2502-R), but it is possible to order the front sun-shields in different colours, which can make the RBS more discrete depending on the environmental surroundings.

The RBS consists of the following main physical units: Mounting Base, Cabinet, Antennas and Sun-shield. This will support a routine of installing the Mounting Base prior to the Cabinet arrival.

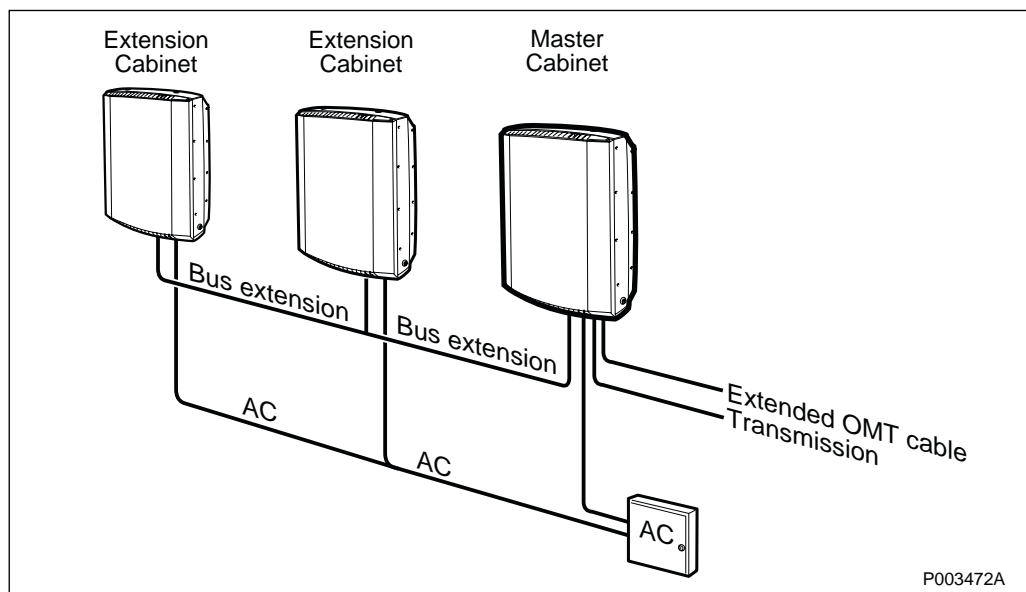

Figure 55 6 TRX site

The prime technical concerns have been to implement a RBS that:

- has a small size (volume and weight), and an appearance suitable for a discrete installation ("landlord friendly").
- has high channel capacity, two transceivers giving total of 15 traffic channels if configured to one cell. The RBS 2302 may be configured with up to six transceivers in one cell by adding extra RBS 2302 as extension cabinets.
- is characterized by low need for preventive maintenance.
- has high MTBF
- has versions for the different system standards GSM 900, GSM 1800 and GSM 1900.

- includes all functions needed for a complete installation of a radio base station, including standard interface G703 2048 kbit/s or DS1 1544 kbit/s to transmission network, AC mains power, battery backup and a choice of internal or external antennas.
- supports Linear Cascade connection on the transmission interface.
- has an extended OMT-port that makes it possible for connection of the OMT at ground level if the RBS 2302 is mounted high on a wall or a pole.
- includes an optional fan-unit which extends the upper temperature limit to +55 C°.
- has space for a transmission module to support other transmission protocols than E1 or T1.
- can be installed by one person.
- supports HSCSD

10.3 Product Architecture

10.3.1 Main Physical Units

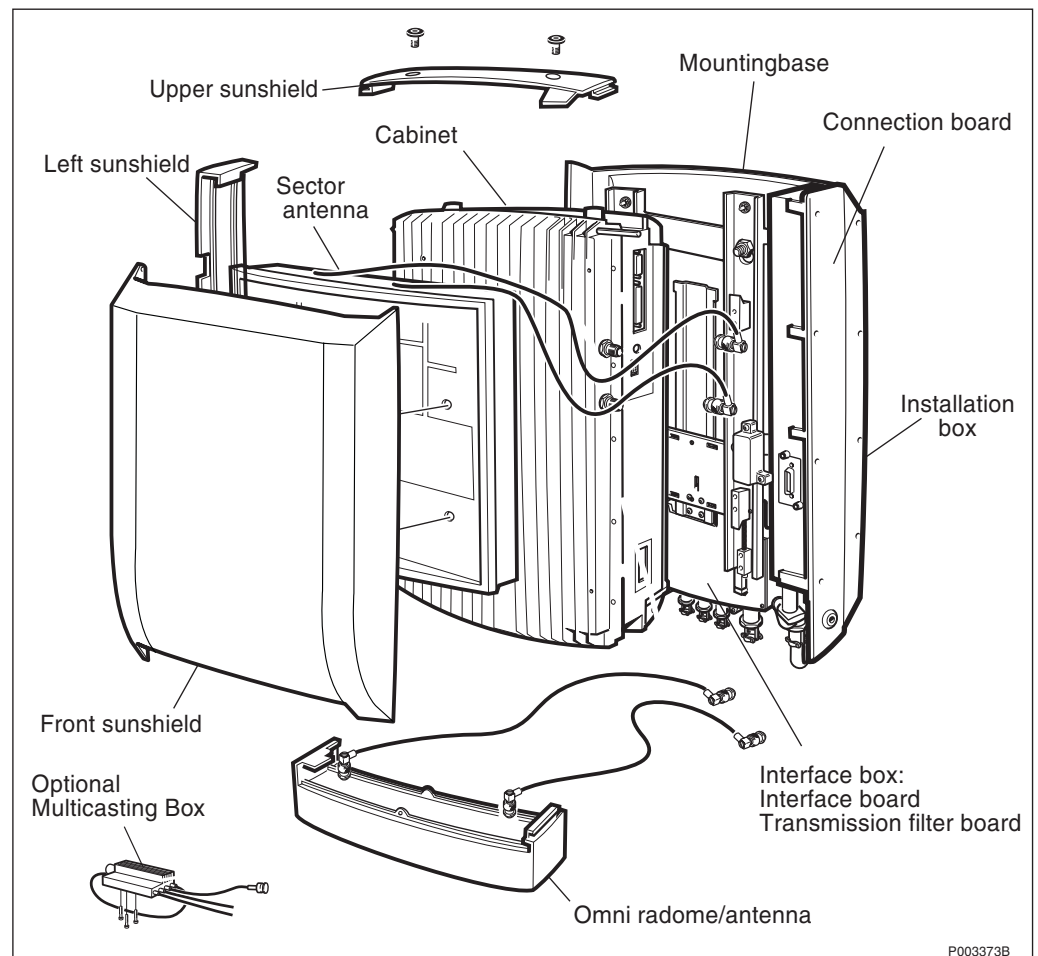

Figure 56 Main Physical Units

10.3.2 Hardware Units

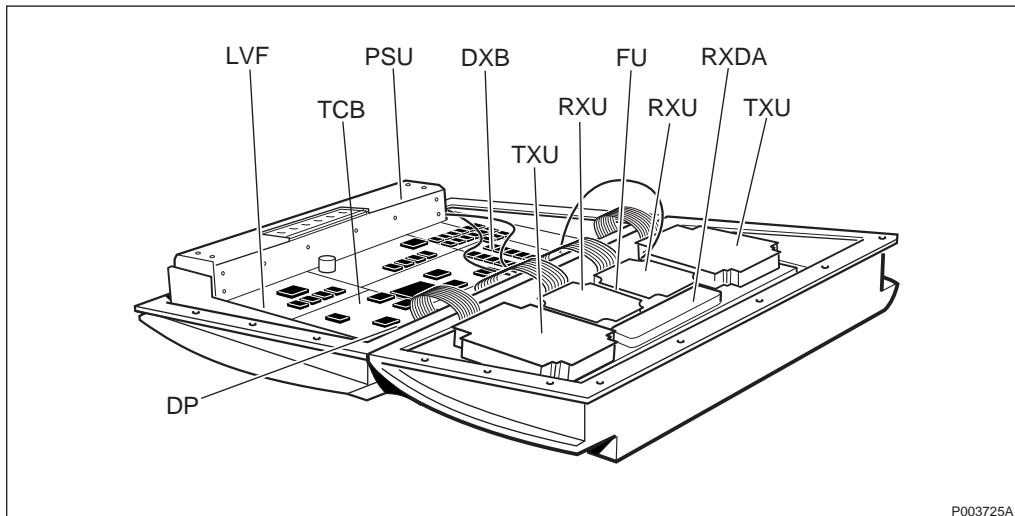
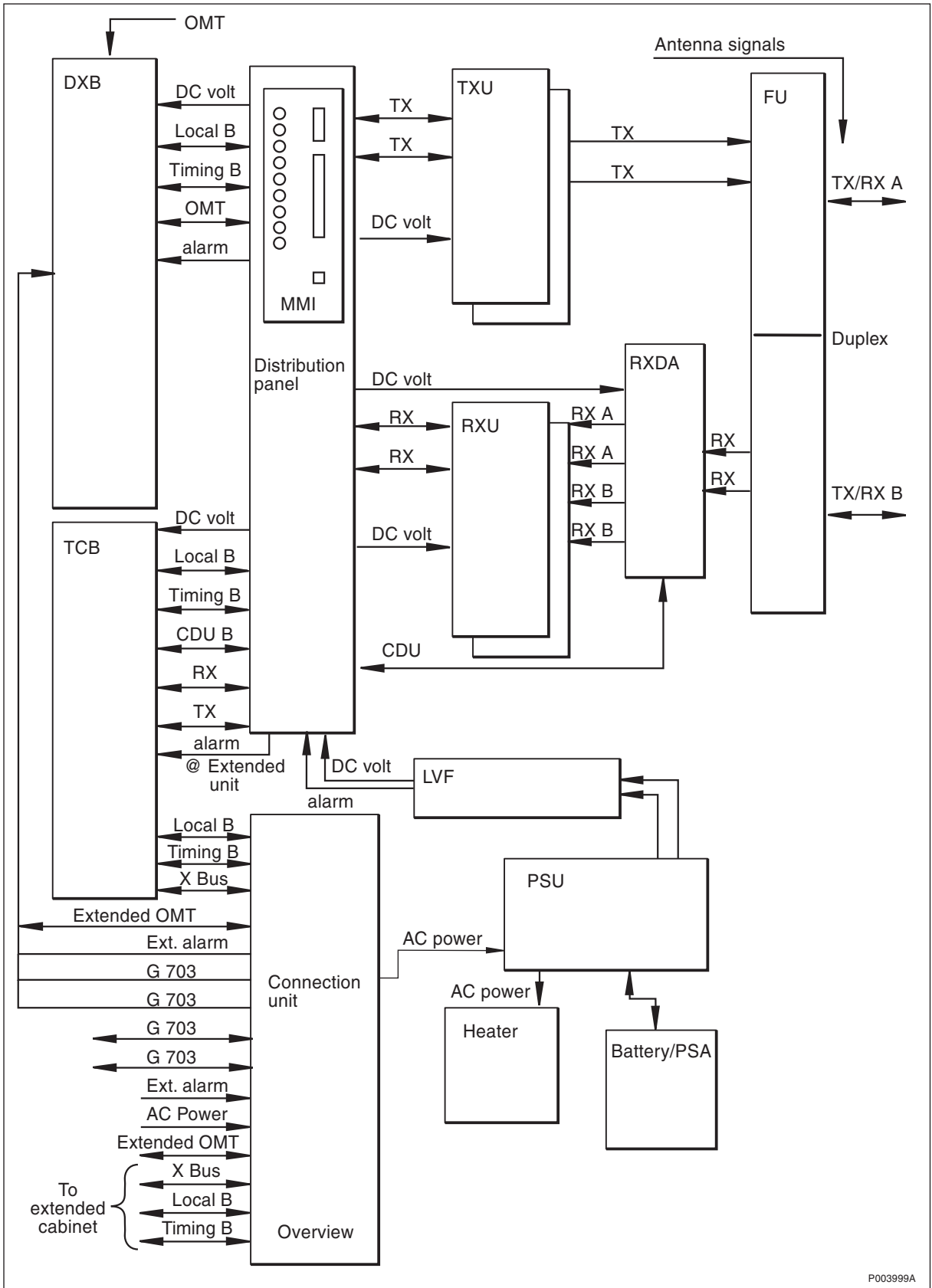

Figure 57 Hardware Units in the Cabinet

| | |
|------|---|
| DXB | <p>Distribution Switching Board</p> <p>The DXB (1 per RBS) is the central control unit for the RBS and supports the transmission interface.</p> |
| OMT | <p>Operation and Maintenance Terminal</p> <p>The OMT is a PC based terminal used during installation and maintenance.</p> |
| TCB | <p>Transceiver Control Board</p> <p>The TCB (2 per RBS) includes equipment related to signal processing for up to two radio carriers.</p> |
| TXU | <p>Transmitter Unit</p> <p>The TXU (2 per RBS) contains equipment for transmission on one radio carrier.</p> |
| RXU | <p>Receiver Unit</p> <p>The RXU (2 per RBS) contains equipment for reception on one radio carrier.</p> |
| RXDA | <p>Receiver Divider Amplifier</p> <p>The RXDA (1 per RBS) contains equipment for low noise amplification of the received radio carrier(s) and dividing each incoming RX into two output carriers.</p> |
| FU | <p>Filtering Unit</p> |

| | |
|--------------------|---|
| | <p>The FU (1 per RBS) is the interface between the transmitters, receivers and the antenna system.</p> |
| LVF | <p>Low Voltage Filter</p> <p>The LVF contains components for voltage filtering.</p> |
| PSU | <p>Power Supply Unit</p> <p>The PSU (1 per RBS), which rectifies the incoming AC mains to regulated DC voltages, controls and supervises the battery and supervises the temperatures inside the cabinet.</p> |
| Climate Equipment | <p>Heater to heat the RBS at a low temperature.</p> |
| Battery | <p>The battery is an internal entity and is replaceable without disturbing traffic handling.</p> |
| Connection Unit | <p>The connection unit contains components for lightning and EMC protection. It also includes fuses, AC mains and battery switch as well as plinths for the external interfaces except for antenna feeders.</p> |
| Distribution Plane | <p>The distribution plane interfaces the DXB, the TCB, the TXUs, the RXUs and the PSU. It also contains the buttons and indicators for the RBS.</p> |



P003999A

Figure 58 Overview

10.4 Configurations

10.4.1 Options

Options are configurations that require additional hardware.

Appearance

The following optional colours are available for the front sun-shield besides the standard colour.

NCS S2010-B70G (Olive green)

NCS S1020-R70B (Sky blue)

NCS S1020-Y90R (Brick red)

NCS S1020-Y50R (Brown)

NCS S1020-Y10R (Yellow)

According to NCS standard.

10.4.2 Variants

Radio Configurations

The RBS will support the following basic configuration alternatives:

Table 22

| GSM 900 | GSM 1800 | GSM 1900 |
|---------|----------|----------|
| M9d_2.2 | M18d_2.2 | M19d_2.2 |

The performance for each configuration is described in chapter Radio Configurations, RBS 2000 Micro.

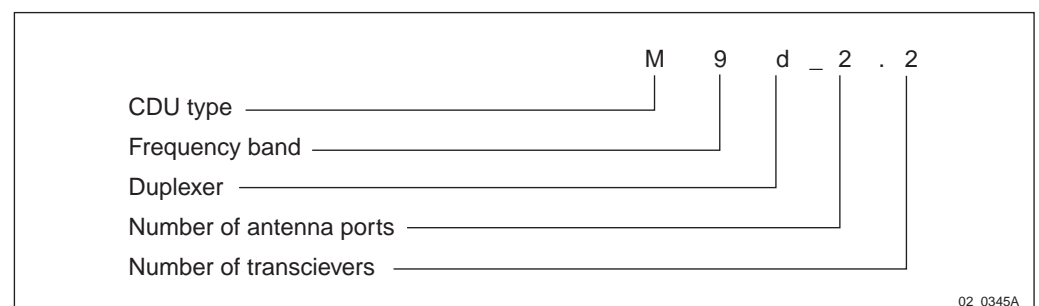

Figure 59 How to read the code

Table 23

| Object | RBS Variants |
|-----------------------------|--|
| Traffic capacity | 2 TRX |
| Encryption | A5/1, A5/2 |
| Transport Network Interface | 1.5 Mbit/s, 100 Ohm 2.0 Mbit/s, 75 Ohm 2.0 Mbit/s, 120 Ohm |
| Filter | Duplex |

It is possible to equip the RBS with either external antennas, integral antennas or an active antenna system (MAXITE™).

Using the active antenna, the RBS supports a "highway configuration", where two TRXs cover two directions as one cell, as specified below.

It is also possible to extend one cabinet with up to two other cabinets to form a 4 or 6 TRX site.

The RBS supports a multicasting box, as specified below.

The RBS 2302 will support the following basic configuration alternatives:

Table 24

| GSM 900 | GSM 1800 | GSM 1900 |
|---------|------------|------------|
| M9d_1.2 | M18d_1.2 | M19d_1.2 |
| | M18d_2.2\H | M19d_2.2\H |
| | M18d_2.2\A | M19d_2.2\A |
| M9d_4.4 | M18d_4.4 | M19d_4.4 |
| | M18d_4.4\A | M19d_4.4\A |
| M9d_6.6 | M18d_6.6 | M19d_6.6 |
| | M18d_6.6\A | M19d_6.6\A |

Integral Antennas

The following sections are available: Omni Antenna or Sector Antenna.

External Passive Antennas

The RBS supports the use of customer specific external antennas.

Multicasting Box

It is possible to connect a multicasting box to the antenna connectors that combine the antenna signals from each TRX to one antenna feeder. The multicasting box is only supported for 2 TRX configurations.

Transmission

It is possible to change the door on the installation box to a wider door with a modem to support HDSL, ISDN or some other protocol.

Extended Temperature Range with Optional Fan Unit

It is possible to extend the temperature range to 55 (45 + 10) degrees Celsius with the optional Fan unit, placed on top of a site installed RBS 2301/2302.

The Fan unit:

- must be connected to 115 or 230 mains supply voltage. The power consumption is below 15 VA.
- consists of three fans and one fan controller box. One binary alarm (from the fan controller box) is connected to the RBS 2301/2302 external alarm.
- is considered as one replaceable unit.

The external AC-cable shall be provided by the customer and the AC must be possible to break during installation/maintenance.

Extended OMT Interfaces

The RBS supports a permanent extension of the OMT-port. The extension cable length may be up to 50 m. The PC end of the extension is designed for outdoor weather protected locations.

External Battery Backup

The RBS supports an external battery backup (the PBC) source using an adapter, mounted in the battery compartment of the RBS. The backup voltage requirements are further specified in chapter Product Specification for Power and Battery Cabinet.

10.4.3 On Site Configurable Options and Variants

On site configurable options and variants are configurations that do not require different or additional hardware, see chapter RBS 2000 Micro, Site Configurations for more details.

10.5 Combinations

Possible combinations are described in *Ordering Information*.

10.6 Transmission Modes

Transmission

The RBS 2302 can be configured for linear cascade mode and stand alone mode. The configuration is performed by means of the OMT.

When used in stand alone mode, PCM port A is connected to the BSC. In this mode, PCM port B cannot be used.

When used in linear cascade mode (multidrop), the RBSs are connected so that the first RBS uses its port A towards the BSC and port B towards the second RBS. The consecutive RBSs are connected in the same way with port A towards the previous RBS (and indirectly the BSC) and port B towards the next RBS, and so forth.

The transmission functionality is further specified in relevant function specifications, see chapter Transmission and Interface Handling G.703 2048 kbit/s and Transmission and Interface Handling DS1 1544 kbit/s.

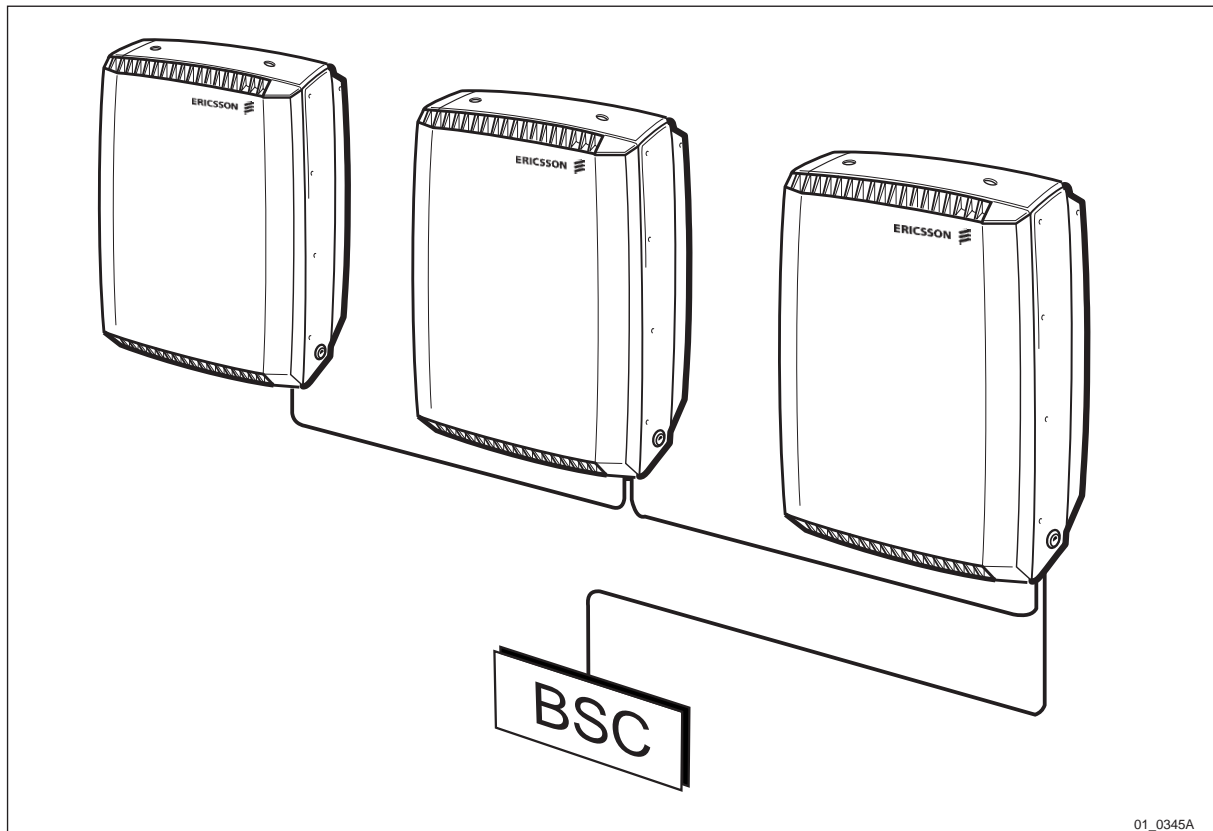

Figure 60 Multidrop chain

10.7 Interface and Connection

10.7.1 External Connections

AC Mains

| | |
|-----------------------|---|
| Type of connections: | Screw terminal for 4 x max. 2.5 mm ² |
| Cable gland capacity: | 1 x Ø 8-19 mm |

External Battery Backup

| | |
|----------------------|--|
| Type of connections: | The adapter must fit the battery compartment of the RBS. |
|----------------------|--|

External Alarms

| | |
|-----------------------|--|
| Type of connections: | Screw terminal for 16 x max. 1.5 mm ² |
| Cable gland capacity: | 2 x Ø 5-9 mm |
| Number of alarms: | 8 |

Antenna Connectors

| | |
|---------------------|-----------------------------|
| Type of connectors: | 2 x TNC (receptacle) female |
|---------------------|-----------------------------|

Note: When using integral antennas, cables and connectors are included. These connection are placed on the cabinet.

Transmission

Twisted pair:

| | |
|-----------------------|--|
| Type of connections: | Screw terminal for 12 x max. 1.5 mm ² |
| Cable gland capacity: | 2 x Ø 7-15 mm |

Coaxial:

| | |
|---------------------|---|
| Type of connection: | 4 x TNC (receptacle) female |
| Grounding: | The transmit wire screen is grounded. It is possible to ground the receive wire screen. |

Earthing

| | |
|---------------------|--|
| Type of connectors: | Central earth terminal point M8 thread |
|---------------------|--|

10.7.2 Internal Connections

OMT

Type of connections: 9 pin D-sub (receptacle) female

Extended OMT-port

Type of connections: 9 pin D-sub female

Maximum cable length: 50 m

Cable gland capacity: 1 x Ø 5-9 mm

10.7.3 Test Interface

The RBS is equipped with test ports for connection of external instruments. The following signals are available at test ports:

13 MHz Reference

Type of connectors: SMB connector (receptacle) male

RTS-PLS Test Port

Type of connectors: No requirements

10.7.4 Operator Interface

The operator interface is located in the Mounting Base. The interface includes indicators and buttons, switches and barcode signs. For exact specification of button and indicator functionality see chapter Operation & Maintenance Support.

Indicators (LEDs)

| | |
|------------------|--|
| Fault | One or more faults, equals BS fault. |
| Operational | At least one TRX operational. |
| Local mode | RBS in local mode. |
| Reduced capacity | One of two TRXs operational. |
| Test TRX1 | Result from TRX1 test operation. |
| Test TRX2 | Result from TRX2 test operation. |
| AC Power on | AC Power is switched on to RBS. |
| Battery fault | Lowbattery DC voltage, battery absent. |
| External alarm | One or more external alarm active. |

Buttons

CPU reset
 Local/remote mode
 Test Operation initiation

Switches

| | |
|----------|-------------------------|
| Battery | connected/not connected |
| AC Mains | connected/not connected |

10.8 Product Requirements**10.8.1 Appearance**

Ericsson products are designed to appear as one physical unit, inconspicuous, pleasant and good-looking. The standard colour of the RBS is Grey.

The front cover of the RBS which is designed as a sun-shield is available in different colours to make the RBS even more inconspicuous.

There is an optional integrated antenna system which supports the idea of the RBS and the antenna site as one unit.

10.8.2 Mechanical Structure**Replaceable Units**

The RBS consists of the following replaceable units:

- Cabinet
- Mounting base
- Installation box door
- Integral antennas

- Sun-shield
- Batteries
- AC-filter board (including overvoltage protection)
- Transmission filter board (including overvoltage protection)
- Wall bracket
- Mast/pole fixture
- Connection board

Locks

The installation box door is equipped with a lock which can be exchanged if necessary.

10.8.3 Dimension and Weight

Volume

The total volume of a complete RBS site without cabling, is less than 35 l.

Size

(HxWxD): 535 x 408 x 160 mm (without integral antennas)

(HxWxD): 535 x 408 x 210 mm (with Sector Antenna)

(HxWxD): 607 x 408 x 160 mm (with Omnidirectional Antenna)

Weight

The total weight is the sum of the following units:

| | |
|---------------|--------------------------------|
| Cabinet | 18 kg (incl. Internal battery) |
| Mounting Base | 8 kg (incl. Sun-shield) |
| Wall bracket | 5 kg (incl. Pole fixture) |
| <hr/> | |
| Total weight | 31 kg |

10.8.4 Hardware Characteristics

Acoustical Noise

The RBS will not contribute to the acoustic noise in the surroundings.

The optional fan-unit contributes with less than 5.5 Bel at temperatures below +30 C° and less than 6.5 at all other temperature.

Vandal Resistance

The RBS is designed as vandal resistant and unauthorized intrusion will not be possible without damaging the unit.

Package Material

The package material is recyclable.

Handling Robustness

The RBS main cabinet is designed to be placed on the ground during installation and maintenance work.

10.8.5 Environment**Operation**

The RBS meets the following requirement for "outdoor mast mounted equipment".

Temperature range: -33° to +45°C
 -33° to +55°C (with fan-unit)

Solar Radiation

The RBS is designed to withstand the additional heat from solar radiation in its specified environment.

Transport

The RBS meets the following transport requirements.

Temperature range: -40°C to +70°C

Storage

The RBS is designed to endure the requirement for storage.

Temperature range: -25°C to +55°C

Handling

The RBS is designed to endure the requirement for handling.

Temperature range: -40°C to +70°C

In addition to this requirement the RBS 2302 can be toppled without damage. Minor damage to the cabinet that is a broken corner of a cooling fin after a topple will not disturb the function of the RBS.

10.8.6 Climate Protection**Climate Protection Principle**

The climate protection maintains the internal temperature within the allowed range for the units in the RBS.

The climate protection of the RBS is handled by a combination of:

- Natural convection with the help of cooling fins
- Conductional heating

The fan-unit increases the air flow over the cooling fins.

Heating Capacity

The system has the capacity to heat the RBS from:

- $-33\text{ }^{\circ}\text{C}$ to starting conditions within 30 minutes
- $-15\text{ }^{\circ}\text{C}$ to starting conditions within 15 minutes

The above only applies if the environmental conditions are: no wind or accumulated ice or snow on the RBS.

Ingression

The RBS fulfils the IP-55 requirements according to the standard IEC 529 and type 3R according to UL50.

10.8.7 Power Supply

Supply Voltage

The RBS can be connected to mains supply voltage with Nominal:

| | | |
|-------------------|------------|------------------|
| 200 - 250 VAC | $\pm 10\%$ | 50 Hz $\pm 10\%$ |
| 100 - 127 VAC | $\pm 10\%$ | 60 Hz $\pm 8\%$ |
| 200/100 - 240/120 | $\pm 10\%$ | 60 Hz $\pm 8\%$ |

The RBS will support installation with:

Single-phase (two-wire; earthed end of phase).

Single-phase (three-wire; earthed mid point).

Single-phase (three-wire; separate PE and N conductor).

According to TN, TT and IT power system.

The AC supply is fused.

Power Consumption

Normal operation, both TRXs transmitting on full output power (at 230 V nominal mains supply): < 140 VA

Maximum power consumption: < 500 VA (only with activated heater).

The optional fan-unit (at 230 V nominal mains supply): < 15 VA

Battery Backup

The RBS will survive interruptions on mains supply for at least 16 minutes. The RBS will maintain full performance during the backup time if the battery is fully charged. The battery will be recharged to at least 80 % of its capacity within 15 hours.

For longer backup time an external UPS or PBC may be used.

Battery Backup (PBC)

The Battery Backup Time is further specified in chapter Site Configuration, RBS 2000 Micro.

10.8.8 Type Approval**Type Approval Standard**

The RBS 2302 fulfils the required type approvals from: GSM 11.20 or GSM 11.21 standard JTC standard FCC rules and regulations. According to requirements in Section Product Safety Requirements RBS 2000.

Product Safety

The RBS 2302, 1900 MHz is listed by the National Recognized Testing Laboratory (NRTL).

EMC

The RBS complies with the European Community market requirements regarding EMC for Base station equipment. The product has the CE sign to show this compliance.

The RBS complies with the US market requirement regarding EMC for Base station equipment. The product has the FCC sign to show this compliance.

The RBS fulfils the electromagnetic requirements for Base station Radio meeting Phase 2 GSM requirements according to ETS 300 342–3.

10.8.9 Dependability**Technical Lifetime**

The RBS is designed for a technical lifetime of 20 years (24 hours operation).

Preventive Maintenance

The RBS has the following availability performance.

| Action | Interval |
|-----------------------------------|---|
| Mean repair time (MRT) | < 60 minutes |
| Mean time between failures (MTBF) | > 10 years |
| Mean accumulated down time (MADT) | < 6 minutes/year (time to reach the site is not included) |

These preventive maintenance conditions must be fulfilled to guarantee the availability figures above.

| Action | Interval |
|--|------------|
| Change of battery | < 5 years |
| Change of lightning protection equipment | < 10 years |
| Calibration of "optional" synchronisation oscillator | <3 years |

10.8.10 Installation

A quick and easy installation procedure is provided. If the installation preconditions are met, the RBS can be installed in less than 30 minutes. A minimum of tools and instruments are required when installing an RBS.

Preconditions

- It is possible to adjust the RBS in vertical direction $\pm 10^\circ$.
- Wall mounting with no visible cables is supported.
- The initiation of the BSC is prepared.
- The transport network is available ¹⁾ at the site
- Mains power is available at site
- Preinstalled antennas and feeders are available ¹⁾
- Wall fixture is preinstalled
- Favourable geographic location and environment (means higher than -10°C , no precipitation and easy access to the site)

¹⁾ "available" means: accessible and with specified function.

Installation Scenario

To support the concept of a quick and smooth installation scenario, the RBS installation work can be divided in to two steps:

- Preinstallation. Installation of the Mounting Base, antennas and all necessary cabling (AC mains, transmission and alarms).

- Installation and Commissioning. Installation of the Cabinet including all parts according to customer ordering.

However, the installation can be performed in one site visit.

The manual operations at installation are few and easy, this is valid also when connecting external cables.

Site Installation Requirement

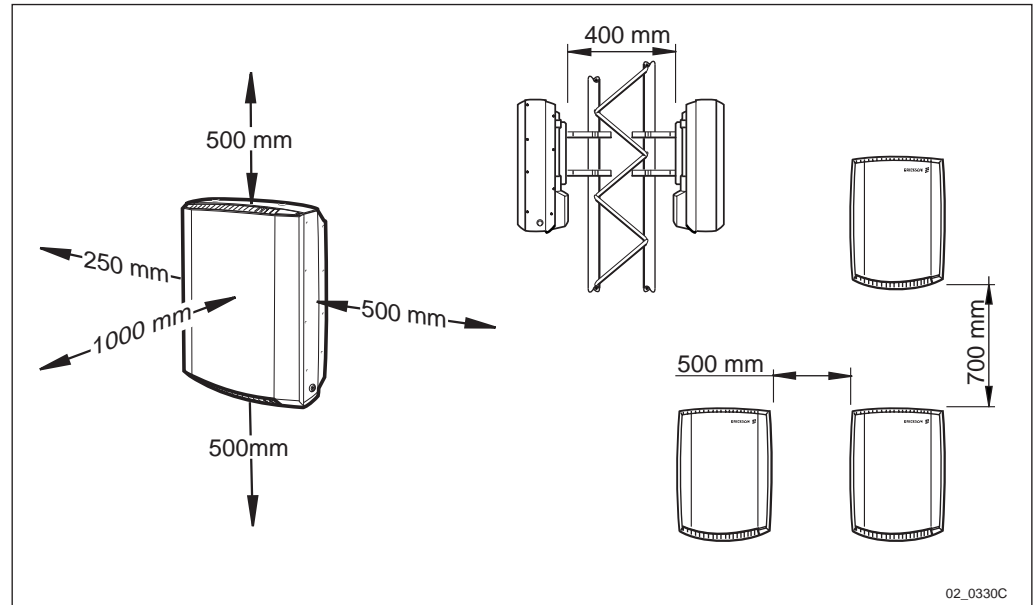

Figure 61 RBS 2302 space requirements

Free space is required around the RBS for installation and maintenance. For a simple installation, the following distances are recommended:

- Front: 1.0 m
- Side: 0.25 m
- Top: 0.5 m
- Bottom: 0.5 m

For 4 and 6 TRX, the maximum distance between the cabinets is 5 m, which is the length of the cable.

If external battery backup is used, the following distances are required:

- Top: 0.7 m
- Bottom: 0.7 m

This page is intentionally left blank

11 Product Specification for RBS 2401

11.1 Terminology

| | |
|--------------------------|--|
| AGW | A gateway between UDP/TCP/IP traffic on Ethernet to A-bis (LAPD) traffic on an E1 interface to the RBS. |
| Antenna System | Is constituted by one or several antennas, directed to cover the same cell. |
| ARP | Refers to one of the two RF feeder connectors. |
| E1 | G.703, 2 Mbit/s transmission system. Mostly used in Europe. |
| Environmental load | The impact a product has on the environment. |
| GPRS CS-1 and CS-2 | Defined coding schemes for the packet data traffic channels. The data rate is 9.05 kb/s for CS-1 and 13.4 kb/s for CS-2 per time slot. |
| HDSL | By use of HDSL transmission it is possible to connect the RBS to physical twisted copper pairs from a BSC or transmission terminal for the A-bis interface. The distance can be longer than with traditional line terminals. |
| IT power system | A power distribution system having no direct connection to earth. The exposed conductive parts of the electrical installation are earthed. |
| Life cycle assessment | Compilation and evaluation of the inputs and outputs and the potential environmental impacts of a product system throughout its entire life cycle, from cradle to grave. |
| Life cycle point of view | The environmental impact from a product during its whole life cycle (from extraction of raw material to end of life treatment) is minimized. |
| Material declaration | The amount and different kind of substances and material included in a product is documented. Material data from suppliers is needed. |
| PCABS | A common plastic which is a mix of the plastics PolyCarbonat and ABS. |

| | |
|---------------------|---|
| Recyclable material | Material that can be recycled after being used in a product. |
| Recycled material | Raw material that has been recycled. |
| Replaceable unit | A Replaceable Unit (RU) is a unit that contains one or more processors, to which software can be downloaded from the BSC. |
| Resource depletion | Consumption of limited resources. |
| T1 | G.703, 1.5 Mbit/s transmission system. Mostly used in USA. |
| TN power system | A power distribution system having one point directly earthed. The exposed conductive parts of the installation are connected to that point by protective earth conductors. |
| Transport Network | The physical network between RBS and BSC. |
| TT power system | A power distribution system having one point directly earthed. The exposed conductive parts of the installation are connected to earth electrodes electrically independent of the earth electrodes of the power system. |

11.2 General

The RBS 2401 is a member of the RBS 2000 family.

The main focus with this product is to reduce site cost and make it possible for our customers to find cost effective site locations, which will ensure customer profitability of indoor RBS cell network.

To be able to support the idea of a small RBS that can be located almost anywhere indoor, some functional limitations have been made.

The cabinet is designed for indoor installations only.

A recommended omni antenna can be ordered as a cabinet antenna, and there is always the possibility to connect external antennas.

The RBS contains a multicasting function which utilises a combination of the antenna signals from the two TRXs.

The metallic parts of the RBS 2401 are painted according to MZY 541 01/975. The front cover and the rest of the plastic details on the RBS have the colour RAL 9010 (White). The operator can paint the front cover, but then Ericsson does not take the responsibility to fulfil the temperature or the recycling requirements.

HDSL is an optional secondary modem. By use of the HDSL transmission it is possible to connect the RBS to physical twisted copper pairs from a BSC or transmission terminal for the A-bis

interface. The distance can be longer than with traditional line terminals, for example need of repeaters will then be reduced.

AGW (A-bis GateWay) is an optional transmission interface. By use of the AGW transmission it is possible to connect the RBS to the LAN instead of a BSC, GSM on the net configuration.

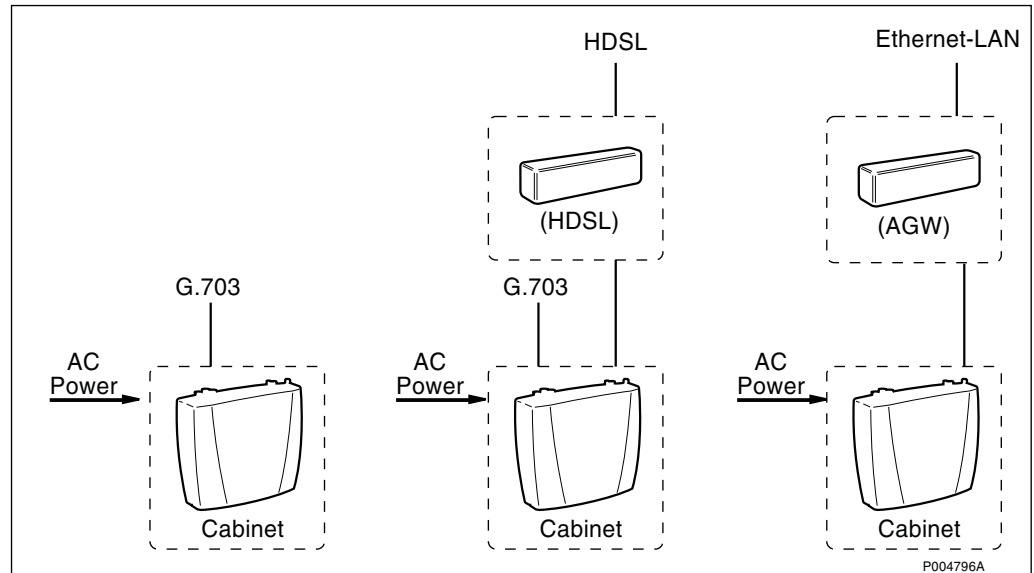

Figure 62 Example of RBS 2401 sites

The main technical features of RBS 2401 are that it:

- has an operating temperature from + 5 °C to + 40 °C.
- has a small size (volume and weight), and an appearance suitable for an "invisible" installation.
- has versions for the two different frequency bands GSM 900 and 1800.
- has two TRXs, class M2 for GSM 900 and class M3 for GSM 1800.
- has high channel capacity, two transceivers giving up to 15 full-rate traffic channels if configured to one cell.
- has cascade (multidrop) functionality for up to five RBSs.
- has versions for different encryption codes (A5.1 and A5.2).
- has 3 DSP Cluster:
 - Half rate
 - 14.4 kbit/s.
- is prepared for GPRS CS-1 and CS-2.
- supports HCSCD.
- has multicasting configuration only, that is, both TXs and RXs are available at the same antenna port. There are two identical antenna ports. One or two antennas/antenna systems may be used. Unused antenna port shall be terminated into a 50 Ω load.

- includes all functions needed for a complete installation of a radio base station, including standard interface G.703 E1 or T1 to transmission network.
- includes AC mains power.
- is characterised of low need for preventive maintenance and is easy to install for one person with no special tools.
- has high MTBF.

11.3 Product Architecture

Main physical units: Mounting bracket, Cabinet and Front Cover.

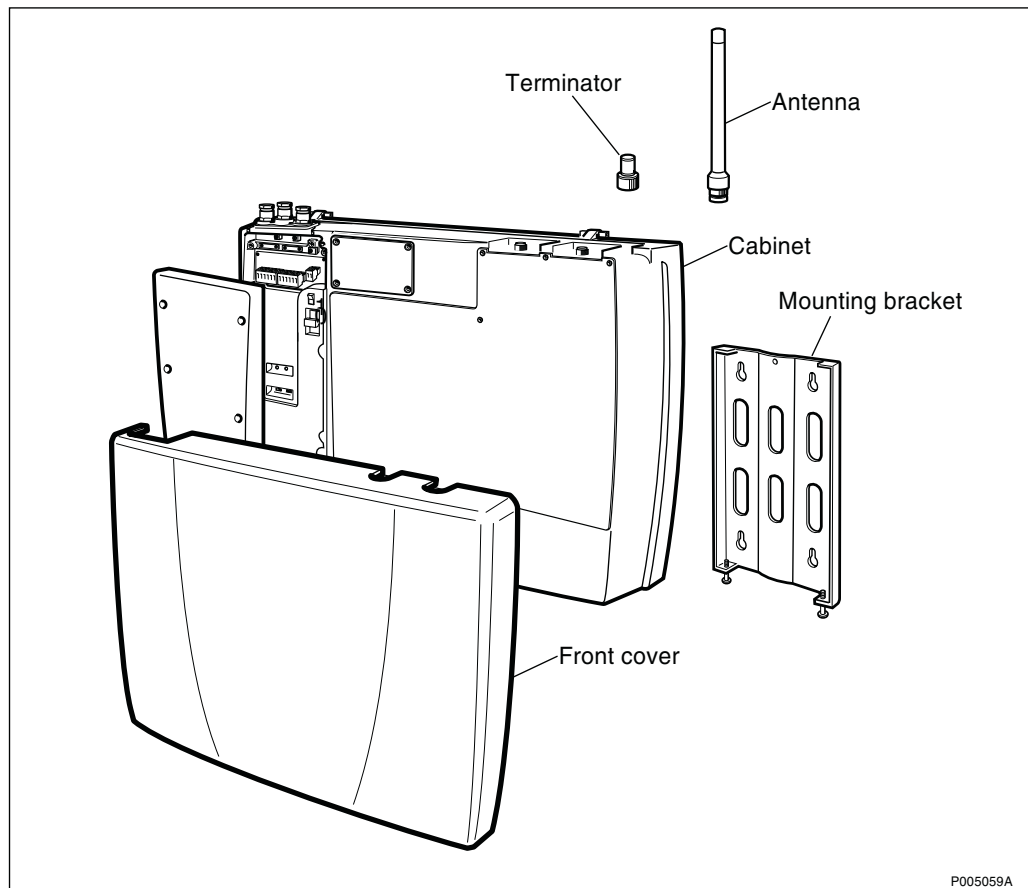

Figure 63 The RBS 2401 cabinet including front cover and mounting bracket seen from different views and the mounting bracket separate

11.4 Configurations

11.4.1 Options

Options are configurations that require additional hardware.

11.4.2 Variants

The RBS shall support each one of the following available basic configuration alternatives:

Table 25

| | |
|-----------|------------|
| GSM 900 | GSM 1800 |
| M9d_1.2\1 | M18d_1.2\1 |

How to read the code:

| | |
|----|---------------------------------------|
| M | CDU type (M = micro/small indoor RBS) |
| 9 | Frequency band (900, 1800) |
| d_ | Filter (d = duplex) |
| 1. | Number of antenna ports |
| 2\ | Number of transceivers |
| 1 | Variant |

Table 26

| | |
|-----------------------------|--|
| Object | RBS variants |
| Traffic capacity | 2 TRX |
| Encryption | A5/1, A5/2 |
| Transport Network Interface | 1.5 Mbit/s, 110 ohm 2.0 Mbit/s, 75 ohm 2.0 Mbit/s, 120 ohm HDSL UDP/TCP/IP |
| Filter | Duplex and Multicasting |

Transmission

It is possible to attach a transmission interface which supports HDSL or UDP/TCP/IP to the RBS 2401.

11.5 Combinations

Possible combinations are described in *Ordering Information*.

11.6 Transmission Modes

It is possible to configure the RBS 2401 both for linear cascade mode and stand alone mode. Cascade mode is the default. Cascade connection is supported for at least five RBSs by making use of drop/multidrop functionality and be able to maintain the frequency stability. The configuration is made with the OMT.

There are two identical transmission ports in the RBS 2401, PCM-A and PCM-B. When the RBS 2401 is used in stand alone mode, PCM port A must be connected towards the BSC. In this mode, PCM port B cannot be used and must be terminated with a load.

When used in linear cascade mode (multidrop), the RBSs must be connected so that the first RBS uses its port A towards the BSC and port B towards the second RBS. The consecutive RBSs must be connected in the same way with port A towards the previous RBS (and indirectly the BSC) and port B towards the next RBS, and so forth. The B port on the last RBS shall be terminated with a load.

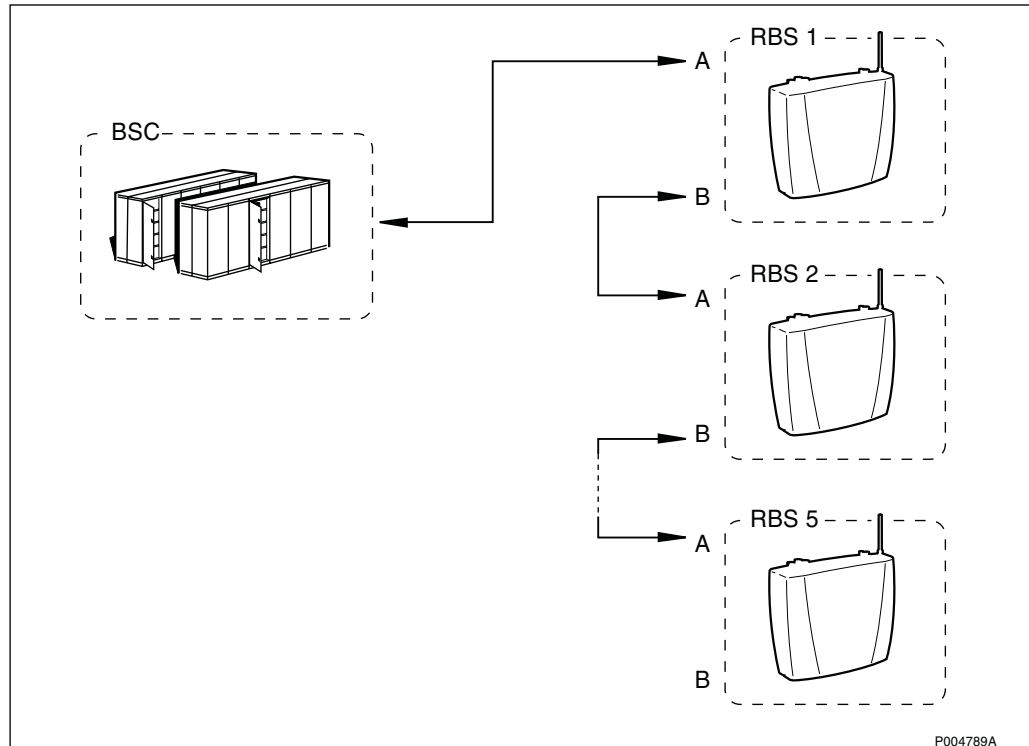

Figure 64 A multidrop chain with five RBSs

11.7 Interfaces and Connections

11.7.1 External Connections

AC Mains

Type of connections: Female tension clamp terminal 2 x max. 2.5 mm²
 Cable gland capacity: 1 x thread PG11 (ø 16 mm)

Antenna Connectors

Type of connectors: 2 x TNC coaxial (receptacle) female

Transmission

Twisted Pair:

Type of connection: Female tension clamp 6 x max. 1.5 mm²

Cable gland capacity: 2 x thread PG11 (ø 16 mm)

Coaxial:

Type of connection: 4 x TNC coaxial (receptacle) female

(A special adapter cable is needed to be able to use a coaxial connector.)

Grounding:

Both the transmitting and the receiving wire screen are possible to ground.

Earthing

Type of connector: Central earth terminal point M4 thread

11.7.2 Internal Connections

OMT-Port

Type of connections: 9 pin D-sub (receptacle) female

11.7.3 Test Interface

The RBS is equipped with test ports for connection of external instruments. The following signals are available at test ports.

13 MHz Reference Port

Type of connectors: SMB coaxial connector (receptacle) male

RTS-PLS Test Port

Type of connectors: Female 30 pin socket connector

11.7.4 Operator Interface

The operator interface is located behind the CPI cover. The interface includes indicators and buttons, switches and barcode labels. (The LEDs are visible from the outside of the RBS.)

It is possible to connect a PC with OMT application.

Indicators (LEDs)

The indicator lights are visible from the outside. The following indicators are used:

| | |
|-------------|----------------------------------|
| Fault | One or more faults. |
| Operational | At least one TRX is operational. |
| Local mode | RBS in local mode. |
| AC Power On | AC Power is switched on to RBS. |

Buttons

CPU reset
Local/remote mode

Switches

The RBS has the following switches:

| | | |
|--------------|--------|-------------------|
| Transmission | PCM A: | 75 Ω or 100/120 Ω |
| Transmission | PCM B: | 75 Ω or 100/120 Ω |
| AC Mains | on/off | |

11.8 Product Requirements

11.8.1 Appearance

The RBS 2401 is designed to appear inconspicuous, pleasant and vandal resistant.

The RBS 2401 front cover is deliverable in one colour, RAL 9010 (White). It is possible for the operator to paint the front cover with paint that is suitable for PCABS.

Painting of the front cover may effect the thermal qualities, and Ericsson will not take responsibility to fulfil the temperature requirements when it is painted. Ericsson does not take the responsibility for recycling if it is painted.

11.8.2 Mechanical Structure

Replaceable Units

The only replaceable unit is the radio cabinet.

11.8.3 Dimension and Weight

Volume

The total visual volume of a complete RBS 2401 site (including the following equipment: cabinet, mounting bracket and front cover but not the cabling) is less than 20 litres.

Size

(HxWxD): 387 x 509 x 127 mm (excluding cable gland and terminator)

(The height including cable gland and terminator is 406 mm. The depth excluding mounting bracket is 122 mm.)

Weight

The total weight is the sum of the following units:

| | |
|------------------|---------------------------|
| Cabinet | 17 kg (incl. front cover) |
| Mounting bracket | 2 kg |
| Total weight | 19 kg |

11.8.4 Hardware Characteristics

The RBS 2401 is designed to fulfil the legal market and Ericsson internal requirements according to product safety on materials.

Acoustical Noise

The RBS will not contribute to the acoustical noise in the surroundings.

Handling Robustness

The cabinet is designed to accept intermediate placing on a flat surface.

11.8.5 Environment

Operation Indoor

RBS 2401 is designed to fulfil the environmental requirements for indoor operation.

Temperature: +5 °C - +40 °C

Transport

The RBS meets the following transport requirements.

Temperature range: -40 °C - +70 °C.

For details see chapter Environmental Capabilities.

Storage

The RBS is designed to endure the requirement for storage.

Temperature range: -25 °C - +55 °C.

For details see chapter Environmental Capabilities.

Handling

The RBS is designed to withstand the requirement for handling.

Temperature range: -40 °C - +70 °C.

For details see chapter Environmental Capabilities.

11.8.6 Climate Protection

Climate Protection Principle

The climate protection of the RBS is handled by natural convection with the help of cooling fins.

Ingression

The RBS fulfils the IP-21 requirements according to the standard IEC 525.

Environmental Control

Before the shut-off the RBS 2401 sends a class 1 alarm. The temperature control supervises the out-of safe-range temperature limit. After the shut-off, when specified operating temperature is obtained, RBS 2401 starts up again.

11.8.7 Power Supply

Supply Voltage

The RBS 2401 supports mains power supply of nominal range:

100 - 127 V AC \pm 10 %, 60 Hz \pm 8 %

200 - 250 V AC \pm 10 %, 50 Hz \pm 10 %

200 V AC \pm 10 %, 60 Hz \pm 8 %

There is an automatic adaptation to 100-127 V AC and 200-250 V AC. The cabinet must be connected to protective earth and the AC shall be fused.

The RBS shall support installation with:

- Single-phase (two-wire; earthed end of phase)
- Single-phase (three-wire; earthed mid-point)
- Single-phase (three-wire; separate PE and N conductor)

according to TN, TT and IT power system.

The power system has a non-destructive range:

Permanent: 0-280 V AC

Short duration overvoltage < 10 ms: 280-300 V AC

Power Consumption

RBS 2401

Maximum power consumption*: < 83 VA

RBS 2401 and HDSL-modem

Maximum power consumption*: < 90 VA

RBS 2401 and AGW

Maximum power consumption*: < 92 VA

* both TRXs are transmitting on full output power and all time slots are active.

11.8.8 Product Safety

The RBS 2401 is designed to fulfil relevant parts of the following standards:

- 73/23/EEC Low Voltage Directive
- EN 60 950
- IEC 215

The RBS 2401 fulfils encapsulation class IP 21.

11.8.9 Antenna System**Antenna Configurations**

The RBS 2401 is multicasting configured, that is, both TRXs are present at the same antenna port.

There are two equivalent antenna ports.

1. Only one antenna port is used, the other antenna port shall in that case be terminated into a 50 Ω load:

One cabinet antenna.

One antenna or distributed antenna system at an external, to the RBS, location.

2. Both antenna ports are used:

One antenna on the cabinet and one antenna or distributed antenna system at an external, to the RBS, location.

Two antenna systems at external, to the RBS, locations.

A distributed antenna system is a system where the same information is distributed to several antennas. The antennas may be located at different antenna sites.

Antenna Site Locations

The antenna site is the location of the antennas.

The antenna system provides 15 dB isolation between antennas, measured in the ARP.

The RBS 2401 supports indoor antenna systems only.

11.8.10 Type Approval

Radio

The RBS 2401 fulfils the radio requirements for Base Station Radio meeting Phase 2+ GSM requirements according to 11.21 rev. EN 301087.

EMC

The RBS 2401 fulfils the electromagnetic requirements for Base Station Radio in the European Community market meeting GSM requirements according to the draft prETS 300 342-3. The product has the CE sign to show this compliance.

11.8.11 Dependability

The annual average temperature used in MTBF calculations is 25 °C.

Technical lifetime

The RBS 2401 is designed for a technical lifetime of 20 years (24 hours operation).

Availability

The RBS has the following availability performance:

- Mean repair time (MRT): 15 minutes
- Mean time between failures (MTBF): > 12 years
- Mean accumulated down time (MADT): < 1.25 minutes/year*

* Logistics time, to reach the site is not included.

Need for manual calibration of delivered RBS, for example due to ageing, is not required.

11.8.12 Limitations

Radio Limitations

- RX and TX diversity is not supported.
- Use of LNA or booster is not supported.
- Frequency planning to avoid IM3-interference into frequencies used by its own receiver must be done.
- RF cable supervision is not supported.
- One RBS 2401 shall always be configured to two TRXs in one cell.

Alarm Limitations

Antenna supervision is not included.

11.8.13 Installation

- The controlling BSC must be prepared to connect towards the new RBS. The complete Transport Network (Transport Module, Minilink, and so forth) must be through-connected from the BSC to the RBS site.
- The mains power must be available.
- The RBS premises must be ready. There must be a wall or similar to mount the cabinet on.
- The antenna systems and feeders must be installed, or must be installed together with the RBS.

11.8.14 Installation Scenario

The manual operations at Cabinet Installation are few and easy. This is also valid when connecting external cables. The installation is performed in one site visit.

When installing more than one RBS at the same site, the RBSs must be separated. Even if a single RBS is installed, there must be a certain distance to the surroundings.

Site Installation Requirement

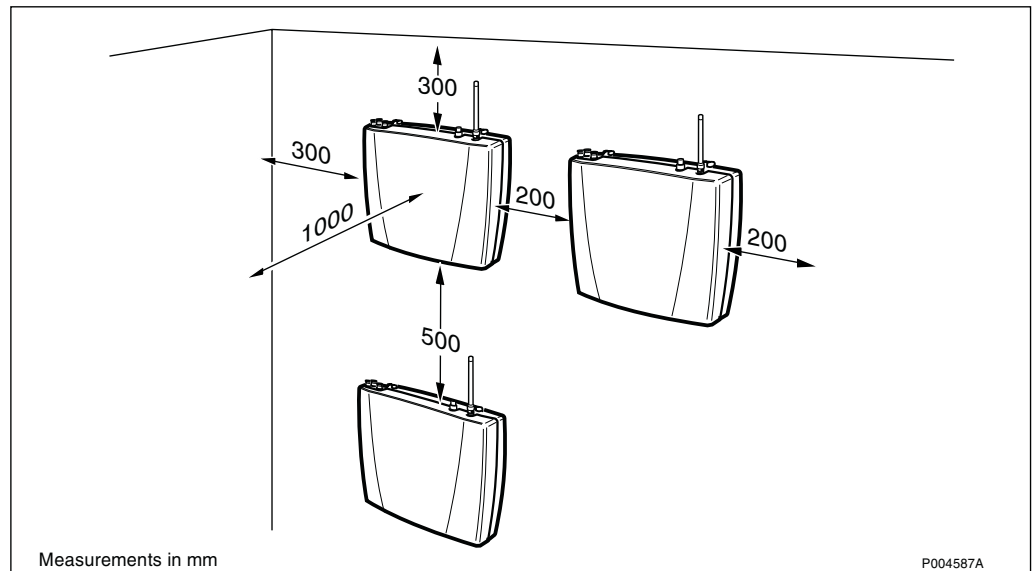

Figure 65 Required space for service

The separation is necessary because of thermal requirements, and to provide sufficient working space. For an installation the following distances are recommended:

- min. separation 0.2 m side by side
- min. separation 0.5 m above/below
- min. separation 0.3 m below inner-roof
- min. 1.0 m distance to obstruction in front of the RBS

This page is intentionally left blank

12 Product Specification for Power and Battery Cabinet

This chapter describes the architecture of the Power and Battery Cabinet (PBC), and specifies its characteristics and performance.

12.1 Terminology

| | |
|------------------|---|
| TN Power System | TN Power System is a power distribution system having one point directly earthed . The exposed conductive parts of the installation are connected to that point by protective earth connectors. |
| TT Power System | TT Power System is a power distribution system having one point directly earthed . The exposed conductive parts of the installation are connected to earth electrodes electrically independent of the earth electrodes of the power system. |
| IT Power System | IT Power System is a power distribution system having no direct connection to earth. The exposed conductive parts of the electrical installation are earthed. |
| Link Equipment | Link Equipment is used to establish contact with the BSC if there is no fixed network between the RBS and the BSC. |
| Second PBC | A second PBC is used in configurations which require two AAUs connected to one RBS. |
| Replaceable Unit | In this document Replaceable Unit refers to units that are replaceable on site. |

12.2 General

The PBC is available in a MAXITE™ configuration or as an option for RBS 2302.

The PBC serves as a common base for battery back-up and power supply to the Active Antenna, the micro RBS and optional transmission equipment (link equipment). The PBC is also an interface for alarms from the Active Antenna and the RBS.

After a complete discharge of the battery the recharging time is less than 24 hours.

In order to reuse already developed parts the mechanical outline is similar to Ericssons micro basestation family. The units are based on modular, standardized assembly structure.

Easy access of the batteries for maintenance without disturbing the traffic.

The weather-proof cabinet and design make it ideal for installation indoor, outdoor, on poles, walls or masts.

The base colour of the PBC is grey, but it is possible to order the front sun-shields in different colours, which can make the PBC more discrete depending on the environmental surroundings.

The PBC is built up by the following main physical units: Battery Cabinet, Sun-shields, Lid and Mounting Base where Installation Box and Interface Box are included. This will support a routine of installing the Mounting Base prior to the Cabinet arrival.

The PBC has the same width and length as the micro RBS but the rear sun-shield is modified to achieve the additional volume needed to fit the batteries.

12.3 Product Architecture

12.3.1 Main Physical Units

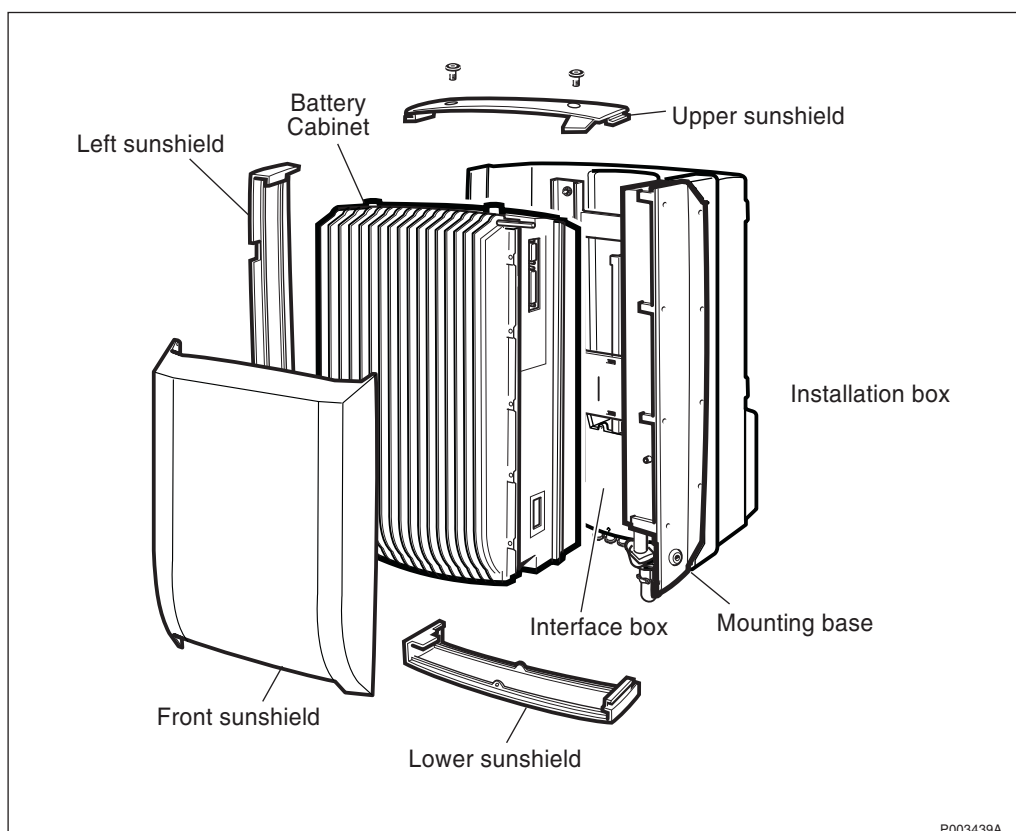

Figure 66 Main Physical Units

BC

Battery Cabinet

The BC contains a AC/DC converter and batteries for DC-backup. The batteries are replaceable without disturbing traffic handling.

Installation Box

The Installation Box contains the MMI-area.

| | |
|---------------|--|
| Interface Box | <p>The Interface Box contains all ports to external equipment as follows:</p> <ul style="list-style-type: none"> AC Mains to PBC –48 V to link equipment –48 V and Data to AAU in the same port two ports 24 V to RBS alarm port from second PBC binary alarms to the RBS <p>The Interface Box also contains surge protection devices on all external terminals. The internal interface is designed so that it is possible to remove the surge protection devices and install an optional reinforced surge device.</p> |
| Mounting Base | The Mounting Base serves as a base for the Battery Cabinet. |
| Sun-shield | The Sun-shields protect the PBC from sun, wind, rain and snow. |

12.4 Configurations

12.4.1 Options

Options are configurations that require additional hardware.

Appearance

The following optional colours are available for the sun-shields besides the standard colour.

| | |
|----------------|---------------|
| NCS S2010-B70G | (Olive green) |
| NCS S1020-R70B | (Sky blue) |
| NCS S1020-Y90R | (Brick red) |
| NCS S1020-Y50R | (Brown) |
| NCS S1020-Y10R | (Yellow) |

According to NCS standard.

12.4.2 On Site Configurable Options and Variants

On site configurable options and variants are configurations that do not require different or additional hardware, see chapter RBS 2000 Micro, Site Configurations for more details.

12.5 Combinations

Possible combinations are described in *Ordering Information*.

12.6 Interface and Connection

12.6.1 External Connections

AC Mains

Type of connections: Screw terminal for 3 x max. 2.5 mm²
Cable gland capacity: 1 times Ø 10.5-14 mm

Data/DC port

Type of connections: Data and -48 V
Cable gland capacity: 1 times Ø 14-16 mm

Data

Type of connections: Screw terminal for 2 x max. 0.6 mm²
Cable gland capacity: See Data/DC port

Earthing

Type of connectors: Central earth terminal point M8 thread

Binary Alarms

The PBC has eight alarm terminals. Four of them are used to connect the RBS. The remaining four terminals are used to connect the external alarms from the second PBC.

PBC Alarms to RBS

Type of connections: Screw terminal for 4 x 2 x max.1.5 mm²
Cable gland capacity: 1 times Ø 7.5-9.5 mm
Number of alarms: 4

PBC Alarms from second PBC

Type of connections: Screw terminal for 4 x 2 x max.1.5 mm²
Cable gland capacity: 1 times Ø 7.5-9.5 mm
Number of alarms: 4

+24 Volt DC

The PBC supplies two regulated DC voltages with +24 V. The two voltages are fused separately.

Each voltage supplies the RBS with DC power. The voltages are galvanically isolated from -48 V and from Cassie/ground.

+24 V, RBS 1

Type of connections: Screw terminal for 2 x max.1.5 mm²
Cable gland capacity: 1 times Ø 7.5-9.5 mm

+24 V, RBS 2

Type of connections: Screw terminal for 2 x max.1.5 mm²
Cable gland capacity: 1 times Ø 7.5-9.5 mm

-48 Volt DC

The PBC supplies two regulated DC voltages with -48 V. The two voltages are fused separately. One voltage supplies the AAU and the other voltage supplies the Link equipment.

The two voltages are positive grounded, that is the terminal with the highest potential is connected to Cassie/ground. The voltages are not galvanically isolated from each other.

-48 V, AAU

Type of connections: Screw terminal for 2 x max. 6 mm²
Cable gland capacity: See Data/DC port

-48 V, Link Equipment

Type of connections: Screw terminal for 2 x max. 2.5 mm²
Cable gland capacity: 1 times Ø 7.5-9.5 mm

12.6.2 Operator Interface

When opening the Lid to the Installation Box there is an MMI area available containing the operational interface which includes two LEDs, three 7-segment indicators and a number of buttons, see the figure below.

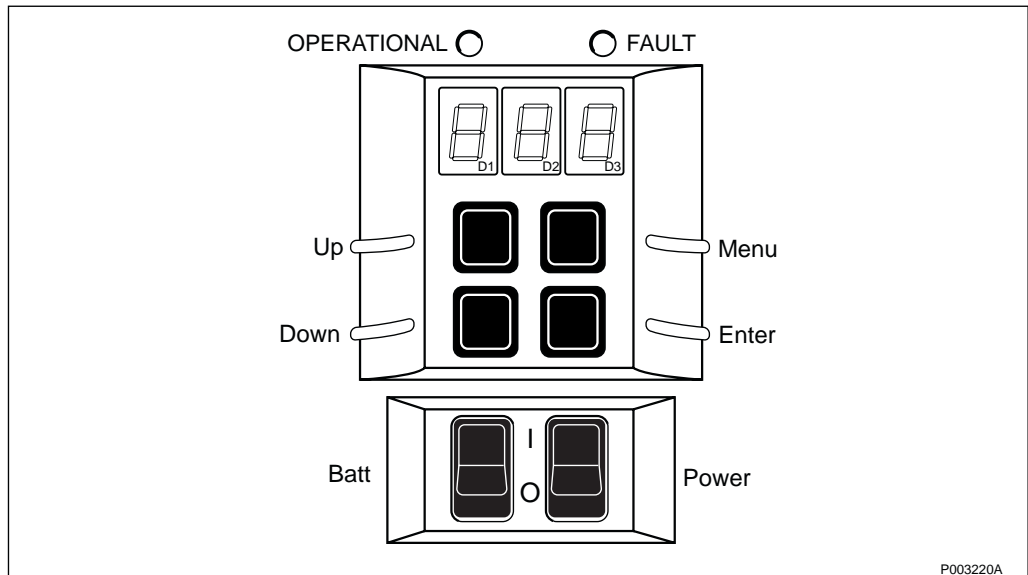

P003220A

Figure 67 MMI Interface

Indicators (LEDs)

Colours

| | |
|----------------|-------------|
| -Green | Operational |
| -Green and red | Warning |
| -Red | Fault |

Display

| | |
|-----------|----------------|
| Display 1 | Unit number |
| Display 2 | Alarm severity |
| Display 3 | Error code |

Buttons

| | |
|-------|----------------------------------|
| Up | Step numbers up on the display |
| Down | Step numbers down on the display |
| Menu | Select between display elements |
| Enter | Transfers commands to AAU |

Barcode Sign

The barcode sign for product identification is readable without disturbing the PBC function.

12.7 Product Requirements

12.7.1 Functional Requirements

MMI Handling

The PBC MMI functions provides the following:

- Supervision of the Antenna alarm signals
- Communication link between the AAU and the PBC
- Supervision of the PBC alarm signals
- Alarm signalling to the RBS
- User interface for installation settings and alarm presentation

Codes on display

Display 1 (D1) shows the unit number as follows:

- 0 = PBC
- 1 = Antenna part 1
- 2 = Antenna part 2
- 3 = Antenna part 3
- 4 =
- 5 = Feeder A
- 6 = Feeder B
- 7 = Installation faults

Antenna part 2 and 3 are used if the antenna consists of more than one unit.

Display 2 (D2) shows the severity of an alarm as follows:

- 0 = Not Classified
- 1 = Severe
- 2 = Warning

The messages for the feeder values also use this element, see below.

Display 3 (D3) shows which type of error has occurred or the command that is transmitted to the AAU as follows:

- 0 = AC fault
- 1 = AC/DC fault
- 2 = DC/DC overload
- 3 = DC/DC fault
- 4 = Battery fault

- 5 = Battery disconnected
- 6 = Low battery voltage
- 7 = Overtemp, active
- 8 = Overtemp, historical
- 9 = Mode fault in PBC

AAU:

- 0 = Transmission fail
- 1 = DC fault
- 2 = TXA fault
- 3 = TXB fault
- 4 = RXA fault
- 5 = RXB fault
- 6 = Overtemp, active
- 7 = Overtemp, historical
- P = Output power off
- H = FDU attenuators set to max

Feeder:

- 0-9 = Cable attenuation value 900 MHz
- 0-12 = Cable attenuation value 1800 MHz/1900 MHz

The attenuation value is allowed to be between 0 and 12, presented in one dB-steps (integers only).

Installation:

- 1 = Feeder A, installation fault
- 2 = Feeder B, installation fault

Note: The alarms Installation fault, Output power off, and FDU attenuators set to max are only used during installation.

Operator Control Buttons

The buttons are used together with the display to initiate the feeder cable attenuation setting and to step through the error codes.

If an alarm error code is received it is immediately shown on the display. If there are several errors, the operator is able to step through the error codes with the UP/DOWN buttons.

All errors displayed are current alarms, that is no history is displayed on the MMI. The temperature alarms are however handled in another way because they are differentiated as active or historical.

12.7.2 Alarm Description

Internal Alarm in the PBC

AC fault

| | |
|------------------|---|
| Raise condition: | Activated if AC mains is below 85 V |
| Cease condition: | Activated if AC mains is more than 88 V |
| Alarm severity: | Warning |
| Action: | None |

AC/DC fault

| | |
|------------------|--|
| Raise condition: | Activated if output voltage from PSU is less than 41.5 V |
| Cease condition: | The normal voltage has returned |
| Alarm severity: | Warning |
| Action: | None |

DC/DC overload

| | |
|------------------|---|
| Raise condition: | Activated if one of the two 24 V outputs are overloaded, for example, the current is outside specified value. |
| Cease condition: | The load must be disconnected and the current must be within specified values. |
| Alarm severity: | Warning |
| Action: | To release the current limiting protection, the load must be disconnected. |

DC/DC fault

| | |
|------------------|--|
| Raise condition: | Activated with low output voltage or high temperature in DC/DC & Supervisor. |
| Cease condition: | The normal voltage and the temperature has returned. |
| Alarm severity: | Warning |
| Action: | None |

Battery fault

| | |
|------------------|--|
| Raise condition: | Activated if the battery is faulty or if charging is not operating normally. |
|------------------|--|

| | |
|------------------|--|
| Cease condition: | Correct battery or normal charging has returned. |
| Alarm severity: | Warning |
| Action: | None |

Battery disconnected

| | |
|------------------|--|
| Raise condition: | Activated if the battery is not connected to the battery switches. |
| Cease condition: | The battery is connected. |
| Alarm severity: | Warning |
| Action: | Connect the battery switches. |

Low battery voltage

| | |
|------------------|---|
| Raise condition: | Activated if the battery voltage is less than 43.5 V. |
| Cease condition: | When the battery voltage is more than 43.5 V. |
| Alarm severity: | Warning |
| Action: | None |

Overtemperature, active

| | |
|------------------|---|
| Raise condition: | Overtemperature in the PSU or the DC/DC supervisor. |
| Cease condition: | When the internal temperature has returned. |
| Alarm severity: | Warning |
| Action: | None |

Overtemperature, historical

| | |
|------------------|---|
| Raise condition: | Overtemperature in the PSU or the DC/DC supervisor. |
| Cease condition: | Manual reset |
| Alarm severity: | Warning |
| Action: | None |

The PBC internal alarms are mapped to the following binary alarms:

| | |
|----------|------------------------------|
| SEVERE_A | AAU, carrier A, severe |
| SEVERE_B | AAU, carrier B, severe |
| WARNING | AAU, carrier A or B, warning |
| POWER | PBC, any error, warning |

12.7.3 Appearance

Ericsson products are designed to appear as one physical unit, inconspicuous, pleasant and good-looking. The standard colour of the RBS is grey.

The front cover of the PBC which is designed as a sun-shield may be ordered in different colours to make the PBC even more discrete.

12.7.4 Mechanical Structure

Replaceable Units

The PBC consists of the following replaceable units:

- Battery Cabinet
- Mounting base
- Installation box cover
- Interface box
- Sun-shields
- Batteries
- Mounting plate
- Mast/pole fixture
- Lightning protection unit
- Protection Cover

Labels

All signs are placed to fulfil the requirements behind the purpose and reason for the signs. All signs that are needed for identification of the product and its compliance are readable without disturbing the PBC function.

12.7.5 Dimension and Weight

Volume

The total volume of a complete PBC site without cabling, is less than 56 l.

Size

(HxWxD): 535 x 408 x 330 mm.

Weight

| | |
|-----------------|--------|
| Battery Cabinet | 23 kg |
| Batteries | 21 kg |
| Mounting Base | 9.5 kg |
| Mounting Plate | 3.0 kg |
| Sunshields | 1.5 kg |
| <hr/> | |
| Total weight | 58 kg |

12.7.6 Hardware Characteristics

Acoustic Noise

The PBC will not contribute to the acoustic noise in the surroundings.

Vandal Resistance

The PBC is designed to be vandal resistant and unauthorized intrusion will not be possible without damaging the unit.

Package Material

The package material is recyclable.

Handling Robustness

The PBC main cabinet is designed to accept intermediate placing on the ground during installation and maintenance work.

12.7.7 Environment

Operation

The PBC is designed to endure the requirement for Outdoor Mast Mounted Equipment.

Temperature range: -33°- +45°C

Operating at battery backup: -10°- +45°C

Solar Radiation

The PBC is designed to withstand the additional heat from solar radiation in its specified environment.

Transport

The PBC meets the following transport requirement.

Temperature range: $-40^{\circ}\text{C} - +70^{\circ}\text{C}$

Storage

The PBC meets the following storage requirement.

Temperature range: $-25^{\circ}\text{C} - +55^{\circ}\text{C}$

Handling

Temperature range: $-40^{\circ}\text{C} - +70^{\circ}\text{C}$

The PBC is designed to be placed on the ground.

In addition to this requirement the PBC will endure a topple. Minor damages to the cabinet, for example a broken corner of a cooling fin after a topple, will not disturb the function of the PBC.

12.7.8 Climate Protection

Climate Protection Principle

The climate protection maintains the internal temperature within allowed range for the units in the PBC.

The climate protection of the PBC is handled by a combination of:

- Natural convection using cooling fins
- Conductional heating

Battery Heating Capacity

The system delivers DC to the external users independent of temperature.

The system has the capacity to heat the batteries from -33°C to start charging within 30 minutes (15 minutes from -15°C) if the environmental conditions are no wind.

The above applies if the environmental conditions are: no wind or accumulated ice or snow on the PBC.

During back-up mode the heater is not operational.

Ingression

The PBC fulfils the IP-55 requirements according to the standard IEC 529 and type 3R according to UL50.

12.7.9 Power Supply

Input Supply Voltage

The PBC can be connected to mains supply voltage with Nominal:

| | | |
|-------------------|-------|-------------|
| 200 - 250 VAC | ±10 % | 50 Hz ±10 % |
| 100 - 127 VAC | ±10 % | 60 Hz ± 8 % |
| 200/100 - 240/120 | ±10 % | 60 Hz ± 8 % |

The PBC will support installation with:

Single-phase (two-wire; earthed end of phase).

Single-phase (three-wire; earthed mid point).

Single-phase (three-wire; separate PE and N conductor).

according to TN, TT and IT power system

Output Supply Voltage

The PBC delivers the following output voltages:

RBS

| | | |
|----------------------|--------|-------------------|
| Nominal | + 24 V | range 21.5 - 28 V |
| Nominal load current | 5.2 A | |

AAU

| | | |
|----------------------|---------|--------------------|
| Nominal | -54.1 V | range -41.3 - -60V |
| Nominal load current | 4.0 A | |

Link

| | | |
|----------------------|---------|--------------------|
| Nominal | -54.1 V | range -41.3 - -60V |
| Nominal load current | 0.6 A | |

Power Consumption

Regarding Power Consumption figures see chapter General Specification for RBS 2000 Micro Site Configuration.

Battery Backup

The PBC battery backup time is between 1.5–3 hours depending on which configuration is used. The battery will be recharged within 24 hours.

For longer backup time an external UPS may be used.

12.7.10 Type Approval

Type Approval Standard

The PBC fulfils the required type approvals from: GSM 11.20 or GSM 11.21 standard JTC standard FCC rules and regulations. According to requirements in Section Product Safety Requirements RBS 2000.

Product Safety

The PBC is listed by the National Recognized Testing Laboratory (NRTL).

EMC

The PBC complies with the European Community market requirements regarding EMC for Base station equipment. The product has the CE sign to show this compliance.

The PBC complies with the US market requirement regarding EMC for Base station equipment. The product has the FCC sign to show this compliance.

The PBC fulfils the electromagnetic requirements for Base station Radio meeting Phase 2 GSM requirements according to ETS 300 342-3.

12.7.11 Dependability

Technical Lifetime

The PBC is designed for a technical lifetime of 20 years (24 hours operation).

Preventive Maintenance

The PBC has the following availability performance.

| Action | Interval |
|-----------------------------------|--|
| Mean repair time (MRT) | < 30 minutes |
| Mean time between failures (MTBF) | 28 years |
| Mean accumulated down time (MADT) | <1 minutes/year (time to reach the site is not included) |

These preventive maintenance conditions must be fulfilled to guarantee the availability figures above.

| Action | Interval |
|----------------------------|--|
| Change of battery | < 10 years (with an annual temperature of +20°C) |
| Surge protection equipment | < 10 years |

Fault Localization

In the PBC all active subunits are identified and the address of faulty subunit is stored in a flash memory. This makes it possible for the

repair center to perform a fast and accurate repair on the PBC without any calibration.

12.7.12 Installation

A quick and easy installation procedure is provided. If the installation preconditions are met, the PBC can be installed in less than 30 minutes. A minimum of tools and instruments are required when installing a PBC.

Installation Scenario

To support the concept of a quick and smooth installation scenario, the PBC installation work can be divided in to two steps:

- Preinstallation. Installation of the Mounting Base, antennas and all necessary cabling (AC mains and alarms).
- Installation and Commissioning. Installation of the Cabinet including all parts according to customer ordering.

However, it is possible to perform the installation in one site visit.

The manual operations at installation are few and easy. This is valid also when connecting external cables.

Site Installation Requirement

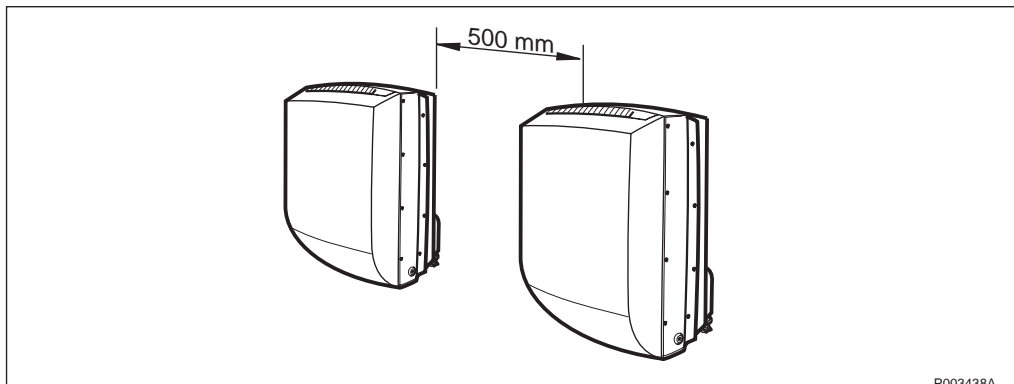

Figure 68 Wall Mounting side by side

Free space is required around the PBC for installation and maintenance. For a simple installation, the following distances are recommended:

- Front: 1.0 m
- Side: 0.5 m
- Top: 0.5 m
- Bottom: 0.5 m

12.7.13 Production

The concept for the PBC supports production according to customer choice from the ordering information plan.

13 Product Specification for 500 W Active Antenna Unit

This chapter describes the architecture and specifies the characteristics and performance of the 500 W Active Antenna Units.

13.1 Terminology

| | |
|----------|--|
| ARP | Antenna Reference Point |
| RBS ARP | Feeder connector on the RBS 2302 |
| AAU | Active Antenna Unit The AAU consists of a single module containing a passive antenna, two transmit paths and two receive paths which include integrated power amplifiers and low noise amplifiers. |
| PBC | Power Battery Cabinet The PBC comprises an AC/DC converter for the AAU, -48 V, and battery, DC/DC (+24 V) for battery backup of the RBS 2302 and communication interface to the AAU. Alarms originated in the AAU or the PBC are converted and transferred to the RBS 2302 external alarm ports. Physically speaking the unit looks like the RBS 2302. |
| RBS 2302 | RBS 2302 is the second generation of GSM micro base station. |
| MAXITE™ | MAXITE™ is a complete package for a radio site for GSM 900, 1800 and 1900. MAXITE consists of RBS 2302, a Power and Battery Cabinet and Active Antenna Unit for GSM 1800/1900, and Coverage Extension Unit plus Passive Antenna for GSM 900. |
| ALPU | Antenna Lightning Protection Unit |
| MMI | Man-Machine Interface |

13.2 General

The Active Antenna 500 W together with the RBS 2302 and PBC is a new base station concept called MAXITE 1800 (500 W) or MAXITE 1900 (500 W) for the Ericsson GSM system. MAXITE is designed for quick and flexible installation on poles, masts or walls and provides maximum coverage area at a low cost.

The main advantages with MAXITE are:

- Increased coverage
- Landlord friendly
- High reliability
- Low cost for the operator
- Small size
- Low weight
- Low power consumption
- Fast and easy installation
- Fast and accurate repair

The Active Antenna Unit consists of a single module containing a passive antenna, two TX and two RX paths and complies with the applicable parts of the GSM and JTC specifications.

13.2.1 **MAXITETM**

MAXITE is designed for installation of the RBS at most various places with the Power Battery Cabinet and the Active Antenna placed mostly outdoors, on poles, masts or walls.

With MAXITE an increased coverage area is achieved at a low cost.

The Active Antenna provides a high EIRP in comparison to its size. A high EIRP and an easy placement is very useful for a fast extension of the network.

MAXITE is more discrete than the traditional macrobase site and the power consumption is much lower for MAXITE than for the macrobase site.

13.3 Product Architecture - Main Physical Units, GSM 1800 (500 W)

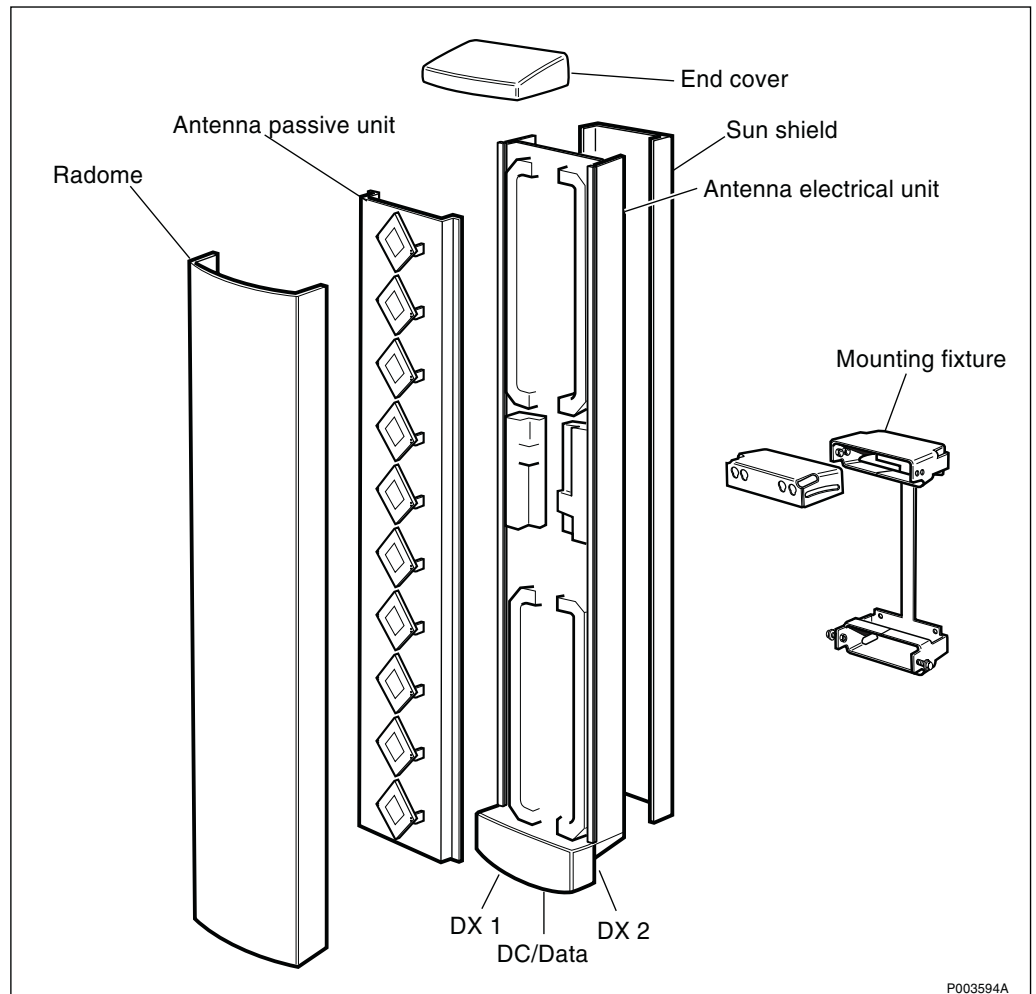

Figure 69 Main physical units, GSM 1800 (500 W)

| | |
|------------------|--|
| Mounting fixture | Keeps the AAU to the basis. It has devices to adjust the elevation angle. |
| AEU | Antenna Electrical Unit The AEU comprises all electrical parts including filters, PAMs, LNAs, mechanical structure etc. |
| APU | Antenna Passive Unit The APU contains the passive parts of the antenna including for example internal RF-connectors and antenna radiating elements. |
| AAU | Antenna Active Unit The AAU comprises an AEU, APU, Sun shield, Radome and End cover. |
| Sun shield | Covers the rear of the AEU. |

End cover Covers the upper part of the AAU.

13.3.1 Configurations

Options

Combinations of possible variants and options are specified according to Ordering Information.

The AAU for GSM 1800 (500 W) is a flexible product and can be ordered according to the table below:

Table 27

| Standards | Beam Width: | |
|--------------------|-------------|----------|
| | Azimuth | Vertical |
| GSM 1800 Full band | 65° | 6.5° |

Variants

As an option a higher level of lightning protection can be ordered as a separate ALPU (Antenna Lightning Protection Unit).

13.3.2 Combinations

Not applicable.

13.3.3 Interface and Connection

Antenna RF Ports (ports between AEU and APU)

V-ARP_A Transmits and receives +45° slant and polarization signals (TX1/RXA).

V-ARP_B Transmits and receives -45° slant and polarization signals (TX2/RXB)

The port supports V-ARP network.

External Connections

RF Connector

The AAU has two duplex RF ports which are located on the bottom end of the AAU.

Type of connectors: N female
 The connectors are marked: DX1 for TX1/RXA (+45°) and DX2 for TX2/RXB (-45°)

Earthing

The central earth terminal is made from a threaded M8 bolt.

DC and Alarm/Data Interfaces

The AAU has a common port for DC power and alarm/data.

The connector type is a circular 6-pin filter connector: AAU Side - RPT 228 910/01 (ITT Cannon 192993-2013)⁽¹⁾

⁽¹⁾ In the ITT Canon number there are no pins or sockets.

| Marking | Signal name | Description |
|-----------|--------------|-------------------------|
| DC data A | DC_-48 V | -48 V from the PBC |
| DC data C | DC_-48 V_RTN | -48 V return to the PBC |
| DC data B | RS485_A | Data |
| DC data D | RS485_B | Data |
| DC data F | RS485_SHIELD | Signal Shield |

Operator Interface

The AAU is a sealed unit and normally situated on a rather unreachable place and therefore all alarms and attenuator values are transported to the PBC where the MMI is located. All types of alarms are displayed in the PBC.

Barcode Sign

The Barcode Sign for product identification is readable without disturbing the AAU function.

13.3.4 Product Requirements

Appearance

Ericsson products are designed to appear as one physical unit, inconspicuous, pleasant and good-looking. The standard colour of the AAU is grey. The Radome and the Sun-shield are possible to paint in different colours according to Ericsson instructions.

Alarm

The alarm/data link communicates with the PBC and it transfers alarm signals and attenuator parameter settings from the AAU as well as it receives a command from the PBC to set the attenuator.

Alarm Description

Failures in the AAU are categorized and reported to the PBC as either WARNING or SEVERE, see below.

WARNING - an error has occurred that either

- decreases the EIRP output level by less than 3 dB
- implies loss of one RX carrier by less than 3.5 dB (diversity)

SEVERE - an error has occurred that either

- decreases the EIRP output level by more than 3 dB
- implies loss of one carrier by more than 3.5 dB (diversity)
- indicates loss of a DC/DC converter which implies EIRP loss by more than 3 dB or at overtemperature

The following alarms are reported to BSC via the PBC:

- TX1 warning
- TX1 severe
- TX2 warning
- TX2 severe
- RXA warning
- RXB warning

Note: If both the RXA and RXB indicate a warning in the PBC or in the DC/DC it automatically indicates a severe fault to the RBS.

Failure Impact

The following table shows the impact on site traffic when a unit is failing in the AAU.

Table 28 Failure Impact, GSM 1800 (500 W)

| Unit(s) failing in AAU | Impact on site traffic | Warning (W) or Severe (S) |
|------------------------|--|---------------------------|
| 1 LNU | -3.5 dB in receive chain one side | W |
| Both LNU | -∞ dB in receive chains both sides | S |
| 1 PA one side | -2.8 dB EIRP one side | W |
| 2 PA one side | -6 dB EIRP (if on same side) | S |
| 1 FDU | -3.5 dB in receive chain and -∞ dB EIRP | S |
| Both FDU | No traffic through site | S |
| Alarm | No data communication to/from AAU, site traffic ok | W |
| 1 side in DC/DC | -3 dB EIRP one side | S |
| Both in DC/DC | No traffic through site | S |
| Overtemp AAU | No traffic through site | S |

Failure Report

The AAU logs and stores failure indications of PAs, LNAs and DC/DC converters in a non-volatile memory. On request, it is possible to read fault indications which are individual and remain even after the power supply is switched off.

Mechanical Structure

Replaceable Units

The AAU system consists of the following replaceable units:

- AAU
- Mounting fixture
- Lightning protection unit

Labels

All signs needed for identification of the product and its compliance are readable without disturbing the RBS function.

Dimension and Weight

Size

(HxWxD): 1400x250x200 mm (GSM 1800).

Weight

The total weight is the sum of the following units:

| | |
|------------------|-------|
| AAU | 30 kg |
| Mounting fixture | 14 kg |
| <hr/> | |
| Total weight | 44 kg |

Hardware Characteristics

Acoustic Noise

The AAU will not contribute to the acoustic noise in the surroundings.

Vandal Resistance

The AAU will appear as vandal resistant and unauthorized intrusion will not be possible without damaging the unit.

Packaging Material

The packaging material is recyclable.

Handling Robustness

The AAU is designed for intermediate placing on the ground during installation and maintenance work. It is important not to place the AAU upside-down.

No connectors protrude outside the external dimensions.

Radio Requirements for GSM 1800 (500 W)

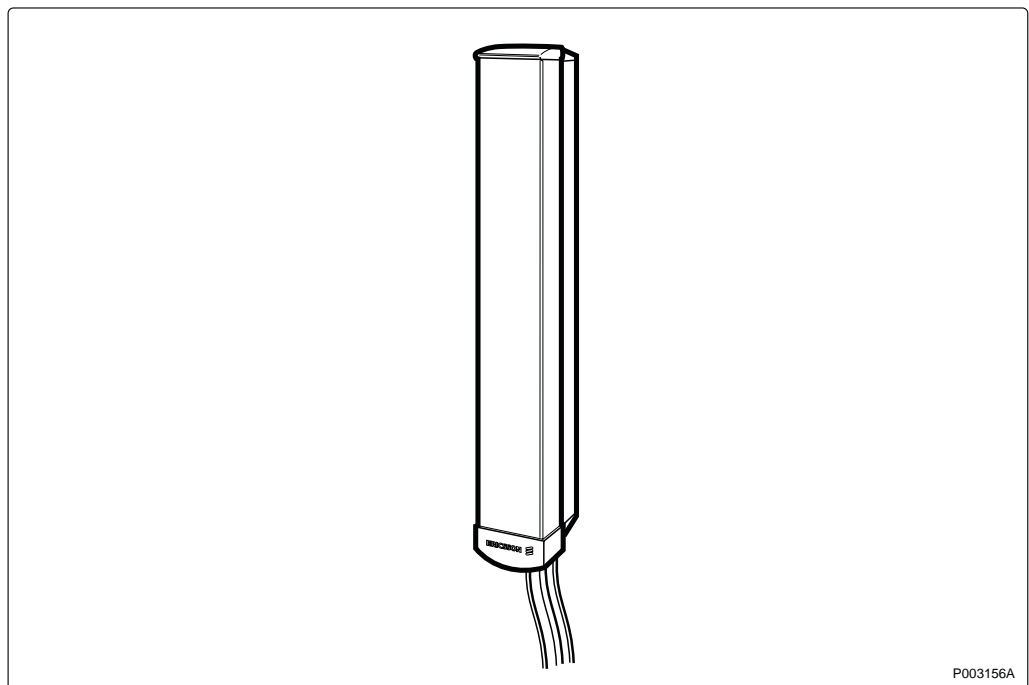

Figure 70 Active Antenna, GSM 1800 (500 W)

In order to balance 500 W EIRP at 1800 MHz the Power Amplifiers, the Low Noise Amplifiers and the Passive Antenna part are integrated in one unit.

Aperture for GSM 1800 (500 W)

| | |
|--|--|
| Azimuth beamwidth (both TX and RX): | 55-70° at -3 dB 110-135° at -10 dB |
| Polarization (relative to vertical plane): | linear $\pm 45^\circ$ |
| Cross polarization ($\pm 60^\circ$ in the polarity planes): | -13 dB |
| Co-polar radiation pattern (in the horizontal plane from channel A to channel B, $\pm 60^\circ$): | 2 dB |
| Front-to-back ratio in the 90° backward sector ($180^\circ \pm 45^\circ$) in the horizontal plane and front-to-back ratio in the 40° backward sector ($180^\circ \pm 20^\circ$) in the vertical plane: | 20 dB |
| Max. beam squint: | < 6° (horizontal plane) < 1° (vertical plane) |

Link Budget for GSM 1800 (500 W)

Note: The values stated below are cell planning values.

Downlink

| | |
|-----------------|---------------|
| BS Output Power | 57.5 dBm EIRP |
| MS Sensitivity | -104 dBm |
| BS Slant Loss | -1.5 dB |
| <hr/> | |
| Path Loss | 160 dB |

Uplink

| | |
|-------------------|-------------|
| MS Output Power | 30 dBm EIRP |
| BS Antenna Gain | 17.5 dBi |
| BS Sensitivity | -111 dBm |
| BS Diversity Gain | 3.5 dB |
| <hr/> | |
| Path Loss | 162 dB |

V-ARP Network

The V-ARP network is used for the verification of the specification and for type approval. It is connected to the Antenna RF ports.

The V-ARP network is an ideal combiner without losses and without any phase and amplitude imbalances.

Environment

Operation

The AAU is designed to endure the requirements stated in chapter Outdoor Mast Mounted Equipment.

Temperature range: -33° to $+45^{\circ}\text{C}$

Solar Radiation

The AAU is designed to withstand the additional heat from solar radiation in its specified environment.

Transport

The AAU meets the following transport requirement.

Temperature range: -40°C to $+70^{\circ}\text{C}$

Storage

The AAU meets the following storage requirement.

Temperature range: -25°C to $+55^{\circ}\text{C}$

Handling

The AAU meets the following requirement for handling. This also applies to the handling of RBS parts during installation and maintenance.

Temperature range: -40°C to $+70^{\circ}\text{C}$

Climate Protection

Climate Protection Principle

The climate protection maintains the internal temperature within the allowed range for the units in the AAU.

If the temperature exceeds the limits, the AAU switches off so that the AAU is not damaged. When the temperature returns within the limits the AAU switches on again.

The climate protection of the AAU is handled by a combination of:

- Natural convection with the help of cooling fins

Ingression

The AAU fulfils the IP-55 requirements according to the standard IEC 529 and type 3R according to UL50.

Power Supply

DC Supply Voltage

DC level -36.3 V to -60 V

The AAU is able to perform a start up after a long power failure.

Power Consumption

Maximum power consumption: 280 W (both TRXs transmitting on full output power)

Type Approval

Type Approval Standard

The AAU fulfils the required type approvals from: GSM 11.20 or GSM 11.21 standard JTC standard FCC rules and regulations. According to requirements in chapter Product Specification of RBS 2302.

EMC

The AAU complies with the European Community market requirements regarding EMC for ancillary RF amplifier. The product has the CE sign to show this compliance.

Dependability

Technical Lifetime

The AAU is designed for a technical lifetime of 20 years (24 hours operation).

Preventive Maintenance

The AAU has the following dependability performance.

| Action | Interval |
|-----------------------------------|---|
| Mean repair time (MRT) | < 30 minutes |
| Mean time between failures (MTBF) | 20 years |
| Mean accumulated down time (MADT) | < 1.5 minutes/year (time to reach the site is not included) |

No preventive maintenance is needed under the lifetime of the AAU.

Installation

A quick and easy installation procedure is provided. A minimum of tools and instruments are required when installing an RBS.

Installation Features

- The mounting fixture is made so that the AAU can be replaced at site without any mechanical adjustment, that is tilt angle and azimuth direction.
- It is possible to install the AAU on conventional one-three sector installations on poles, walls or masts.
- It is possible to adjust the tilt 0°-10°.
- A temporary lifting device can be attached during installation.
- It is possible to locate the AAU 0–100 m from the RBS/PBC with a max. feeder loss of 12 dB.
- No special installation material is required for the MAXITE configuration in comparison with a normal macro site.
- It is possible to expand the AAU in the MAXITE concept with up to three AAU/sector (6 TX channels).

Installation Scenario

At installation, the AAU measures the attenuation between the RBS and the AAU and calculates an attenuator setting. This setting is stored in a non-volatile memory in the AAU and the variable attenuator in the AAU is set to a value with a resolution of ± 0.25 dB in each transmit/receive branch.

Site Installation

When installing more than one AAU at the same site, the AAUs must be separated. The following separation is recommended to provide sufficient working space.

- Min. separation 1 m side by side
- Min. separation 1 m above/below
- Min. separation 1 m back to back

Repair

A faulty active antenna must be replaced by a functional antenna. No repair will be performed at site. In the AAU, all active subunits report faults to a flash memory. At a repair centre the faults can be logged on a fault report making it easier to detect the faulty unit/s.

Production

The concept for the RBS supports production according to customer choice from the ordering information plan.

13.4 Product Architecture - Main Physical Units, GSM 1900 (500 W)

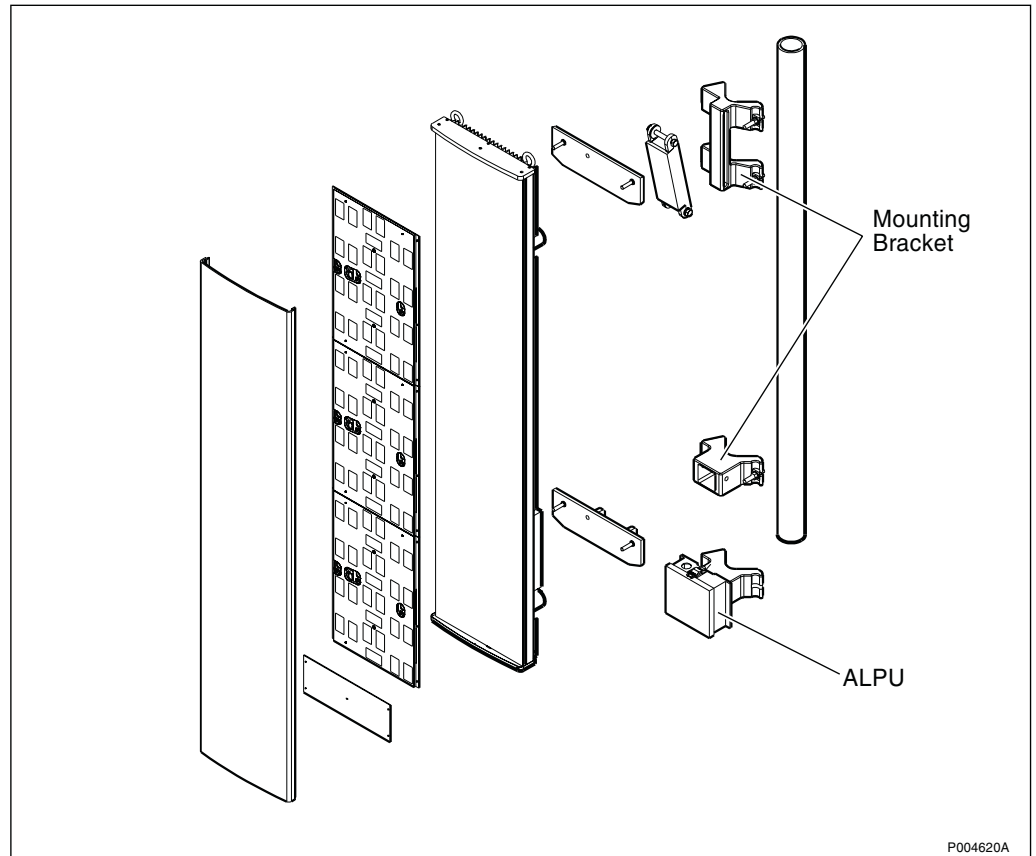

Figure 71 500 W AAU shown with mounting bracket and ALPU

| | |
|------------------|--|
| AAU | <p>Antenna Active Unit</p> <p>The AAU contains two RX and two TX paths. Module is integrated as a single physical unit. An exploded view is shown to illustrate major internal components.</p> |
| ALPU | <p>Antenna Lightning Protection Unit</p> <p>Provides high surge resistance for DC/ Data lines connected to the AAU.</p> |
| Mounting Bracket | <p>Physical pole mount</p> <p>Provides means to adjust elevation angle.</p> |

13.4.1 Configurations

Options

The AAU 500 W can be ordered according to the table below:

Table 29

| GSM 1900 | RX Band | TX Band |
|--------------------|-----------------|-----------------|
| Band A, D (20 MHz) | 1850 - 1870 MHz | 1930 - 1950 MHz |
| Band A, D (20 MHz) | 1870 - 1890 MHz | 1950 - 1970 MHz |
| Band A, D (20 MHz) | 1890 - 1910 MHz | 1970 - 1990 MHz |

Variants

As a recommended option, a higher level of lightning protection for the DC/Data lines can be ordered as a separate ALPU (Antenna Lightning Protection Unit). The AAU contains nominal surge protection for the DC/Data lines.

13.4.2 Combinations

Not applicable.

13.4.3 Interface and Connection

V-ARP_A Receives 90° polarization signals (RXA) and transmits 0° polarization signals (TX1).

V-ARP_B Transmits and receives -45° slant and 0° polarization signals (TX2/RXB).

0° is defined as vertical.

The port supports V-ARP network.

External Connections

RF Connector: The AAU has two duplex RF ports which are located on the bottom end of the module.

Connector Type: 7/16 DIN (Female)

Marking: DX1: TX1/RX A

DX2: TX2/RX B

DC/Data Connector: The AAU has a single bayonet type connector located at the bottom end of the module for the DC/Data connection.

Type: Circular 6-pin filter connector ITT Cannon
192993-2013

Contacts:

| Contact | Signal Name | Description |
|---------|--------------|---------------------|
| A | DC_-48 V | -48 V from PBC |
| C | DC_-48 V_Rtn | -48 V return to PBC |
| B | RS485_A | Data |
| D | RS485_B | Data |
| F | RS485_Shield | Signal shield |
| E | ALPU Alarm | ALPU status |

Marking: DC/Data

Input Power Level: 33.3 to -12.5 dBm

Earthing Terminal: Threaded M8 stud

Operator Interface

The AAU alarms and attenuator values are transported to the PBC where the MMI is located. All types of alarms are displayed in the PBC. No alarms are displayed at the AAU.

Barcode Sign

The Barcode Sign for product identification is readable without disturbing the AAU function.

13.4.4 Product Requirements

Appearance

Ericsson products are designed to appear as one physical unit, inconspicuous, pleasant and good-looking. The colour of the AAU is grey. The Radome is possible to paint in different colours according to Ericsson instructions.

Alarm

The alarm/data link communicates with the PBC and returns alarm signals and attenuator parameter settings from the AAU based on commands from the PBC.

Alarm Description

Failures in the AAU are classified and reported to the PBC as either WARNING or SEVERE.

Error conditions in the AAU that triggers a WARNING alarm:

- Decrease in TX1 or TX2 EIRP by 1 to 4 dB
- Decrease in RX sensitivity by 1 to 4 dB
- Failure of one of two redundant power supplies

Error conditions in the AAU that triggers a SEVERE alarm:

- Decrease in TX1 or TX2 EIRP by more than 4 dB
- Decrease in RX sensitivity by more than 4 dB
- Failure of both redundant power supplies

Alarms reported to the BSC via the PBC:

- TX1 Warning
- TX1 Severe
- TX2 Warning
- TX2 Severe
- RXA Warning
- RXB Warning

If both RXA and RXB indicate a warning in the PBC, a severe fault is reported to the RBS.

Failure Impact

The impact on site traffic due to unit failure in the AAU is shown in the table below.

Table 30 Failure Impact, GSM 1900 (500 W)

| Unit(s) Failing in AAU | Impact on Site Traffic | Warning (W) or Severe (S) |
|-------------------------------|-------------------------|---------------------------|
| 1 PA TX1 or TX2 | < -4 dB EIRP TX1 or TX2 | W |
| 2+ PA TX1 or TX2 | > -4 dB EIRP TX1 or TX2 | S |
| 1-3 LNA(s) RXA or RXB | < -4 dB RX Sensitivity | W |
| 1 LNA RXA and 1 LNA RXB | < -4 dB RX Sensitivity | W |
| 1 LNA RXA/B and 2+ LNAs RXB/A | > -4 dB RX Sensitivity | S |
| 2+ LNA RXA and 2+ LNA RXB | > -4 dB RX Sensitivity | S |
| 1 DC/DC | None | W |
| Both DC/DC | No traffic | S |
| ALPU | None | W * |
| Internal AAU Surge Suppressor | None | W * |

* AAU will report failure of the ALPU if present. If no ALPU is in use, the AAU will report failure of the Internal AAU Surge Suppressor.

Failure Report

The AAU logs and stores failure indications in non-volatile memory. With additional diagnostic tools, it is possible to read specific unit fault indications.

Mechanical Structure

Replaceable Units

The AAU system consists of the following replaceable units:

- AAU
- Mounting Bracket
- Antenna Lightning Protection Unit
- Antenna Lightning Protection Unit Circuit Card Assembly

Labels

All labels required for identification of the product and its compliance are readable external to the AAU.

Dimension and Weight

Size (H x W x D): 2560 x 560 x 130 mm (101 x 22 x 5 inches)
Weight: 40 kg (88 lbs.)

Hardware Characteristics

Acoustic Noise: The AAU will not contribute to the acoustic noise in the surroundings.

Vandal Resistance: The AAU will appear vandal resistant and unauthorized intrusion will not be physically possible without damaging the unit.

Packaging Material: The packaging material is reusable.

Handling Robustness: The AAU is designed to endure being placed on the ground during installation and maintenance work. While resting on the ground, it is important not to place the AAU on the radome or directly on the external connectors.

Radio Requirements for GSM 1900 (500 W)

In order to balance 500 W EIRP at 1900 MHz, the power amplifiers, the low noise amplifiers, and aperture are integrated into one physical unit or module.

Aperture for GSM 1900 (500 W)

| | |
|--|---|
| Azimuth Beamwidth | 55-70° at -3 dB / 110-135° at -10 dB |
| Elevation Beamwidth | > 5° |
| RX Polarization (relative to vertical plane) | Linear 0° and 90° |
| RX Polarization (relative to vertical plane) | Linear 0° |
| Cross polarization ($\pm 60^\circ$ in the polarity plane) | -12 dB minimum |
| Co-polar pattern (horizontal plane from Ch A to Ch) | 2 dB maximum ($\pm 60^\circ$) |
| Front-to-back ratio | -20 dB minimum |
| Beam Squint - Horizontal Plane | < 6° |
| Beam Squint - Vertical Plane | < 1° |
| Receive Diversity Channel Pattern Match | 1 dB |

Link Budget for GSM 1900 (500 W)

Note: The values stated below are cell planning values.

Downlink

| | |
|-----------------|-------------|
| BS Output Power | 57 dBm EIRP |
| MS Sensitivity | -104 dBm |
| <hr/> | |
| Path Loss | 160 dB |

Uplink

| | |
|-------------------|-------------|
| MS Output Power | 30 dBm EIRP |
| BS Antenna Gain | 18.5 dBi |
| BS Sensitivity | -110 dBm |
| BS Diversity Gain | 3.5 dB |
| <hr/> | |
| Path Loss | 162 dB |

V-ARP Network

The V-ARP network is used for the verification of the specification and for type approval. It is connected to the Antenna RF ports.

The V-ARP network is an ideal combiner without losses and without any phase and amplitude imbalances.

Environment

Operation

The AAU is designed to endure the requirements stated in chapter Outdoor Mast Mounted Equipment.

Temperature range: -33° to +45°C

Solar Radiation

The AAU is designed to withstand solar loading of 1120 W/m² over the operating temperature range in accordance with IEC 721-3-4K2k.

Transport

The AAU meets the following transport requirement.

Temperature range: -40°C to +70°C

Storage

The AAU meets the following storage requirement.

Temperature range: -25°C to +55°C

Handling

The AAU meets the following requirements for handling. This also applies to the handling of RBS parts during installation and maintenance.

Temperature range: -40°C to +70°C

Climate Protection

The AAU is passively cooled and does not require any special climate protection to operate in the specified environment.

Power Supply

| | |
|-------------------|---|
| DC Supply Voltage | -38 to -60 V DC |
| Power Consumption | 280 W maximum (all TX1 and TX2 time slots active) |

Type Approval

Type Approval Standard

The AAU fulfils the required type approvals from: GSM 11.20 or GSM 11.21 standard JTC standard FCC rules and regulations. According to requirements in chapter Product Specification of RBS 2302.

EMC

The AAU complies with the European Community market requirements regarding EMC for ancillary RF amplifier. The product has the CE sign to show this compliance.

Dependability

The AAU is designed for a technical lifetime of 20 years (24 hours operation).

Preventive Maintenance

The AAU has the following reliability performance.

| | |
|-----------------------------------|--------------------------|
| Mean Repair Time (MRT) | < 30 minutes |
| Mean Time Between Failures (MTBF) | 750,000 hours (85 years) |

No preventive maintenance is required during the lifetime of the AAU.

Installation

A quick and easy installation procedure is provided. A minimum of tools and instruments are required when installing an AAU.

Installation Features

- The mounting fixture is made so that the AAU can be replaced at site without any mechanical adjustments to the elevation tilt angle or azimuth direction.
- It is possible to install the AAU on conventional one-three sector installations on poles, walls, or masts.
- It is possible to mechanically adjust the elevation tilt angle 0° to -10°.
- It is possible to locate the AAU up to 100 m from the RBS/PBC with a maximum RF feeder loss of 12 dB.
- No special installation material is required for the Maxite configuration in comparison with a normal macro site.

RF Calibration

The AAU self-calibrates on command from the PBC to compensate for up to 12 dB of RF feeder loss. Calibration values are stored in non-volatile memory so that the system will not require re-calibration following unplanned power outages.

Site Installation

When installing more than one AAU at the same site, the AAUs must be physically separated. The following distance is recommended to provide sufficient working space.

- Min. separation 0.2 m side by side

- Min. separation 0.2 m above/below
- Min. separation 0.2 m back to back

Repair

A faulty AAU must be replaced by a functional AAU. No repair will be performed on site.

Production

See the ordering information plan.

This page is intentionally left blank

14 Product Specification for 1250 W Active Antenna Unit

This chapter describes the architecture, and specifies the characteristics and performance of the GSM 1900 1250 W Active Antenna Units.

14.1 Terminology

| | |
|----------|--|
| ARP | Antenna Reference Point |
| | Two ARP are defined in this chapter: - RBS ARP is the feeder connector on the RBS 2302. |
| AAU | Active Antenna Unit |
| | The AAUs are units where the PAs and LNAs are integrated with the antenna elements. The AAUs comprise two separate physical RF channels. |
| PBC | Power Battery Cabinet |
| | The PBC comprises an AC/DC converter for the AAUs -48 V, battery, DC/DC (+24 V) for battery backup of the RBS 2302 and communication interface to the AAUs. Alarms originated in the AAUs or the PBC are converted and transferred to the RBS 2302 external alarm ports. Physically the unit looks like the RBS 2302. |
| RBS 2302 | RBS 2302 is the second generation of GSM micro base station. |
| MAXITE™ | MAXITE™ is a complete package for a radio site for GSM 900, 1800 and 1900. MAXITE consists of RBS 2302, a Power and Battery Cabinet and Active Antenna Unit for GSM 1800/1900, and Coverage Extension Unit plus Passive Antenna for GSM 900. |
| ALPU | Antenna Lightning Protection Unit |
| MMI | Man-Machine Interface |

14.2 General

The AAU consists of two modules; that is, a Base module and a TX module. The Base module contains the dual-polarization receive path and a single transmit path. The optional TX module provides a second transmit path.

The AAU together with the RBS 2302 and Power Battery Cabinet is a new base station concept called MAXITE for the Ericsson GSM system.

The main advantages with MAXITE are:

- Increased coverage
- Landlord friendly
- High reliability
- Low cost for the operator
- Small size
- Low weight
- Fast and easy installation
- Fast and accurate repair

The AAUs comply with the applicable parts of the GSM and JTC specifications.

The weather-proof AAUs are ideal for installation indoor, outdoor, on poles, walls or masts.

14.2.1

MAXITETM

MAXITE is designed for flexible and quick installation on poles, masts or walls.

The MAXITE is a micro-RBS based cell site with macro coverage. The 2 TRX RBS provides maximum range of coverage at a low cost.

14.3 Product Architecture

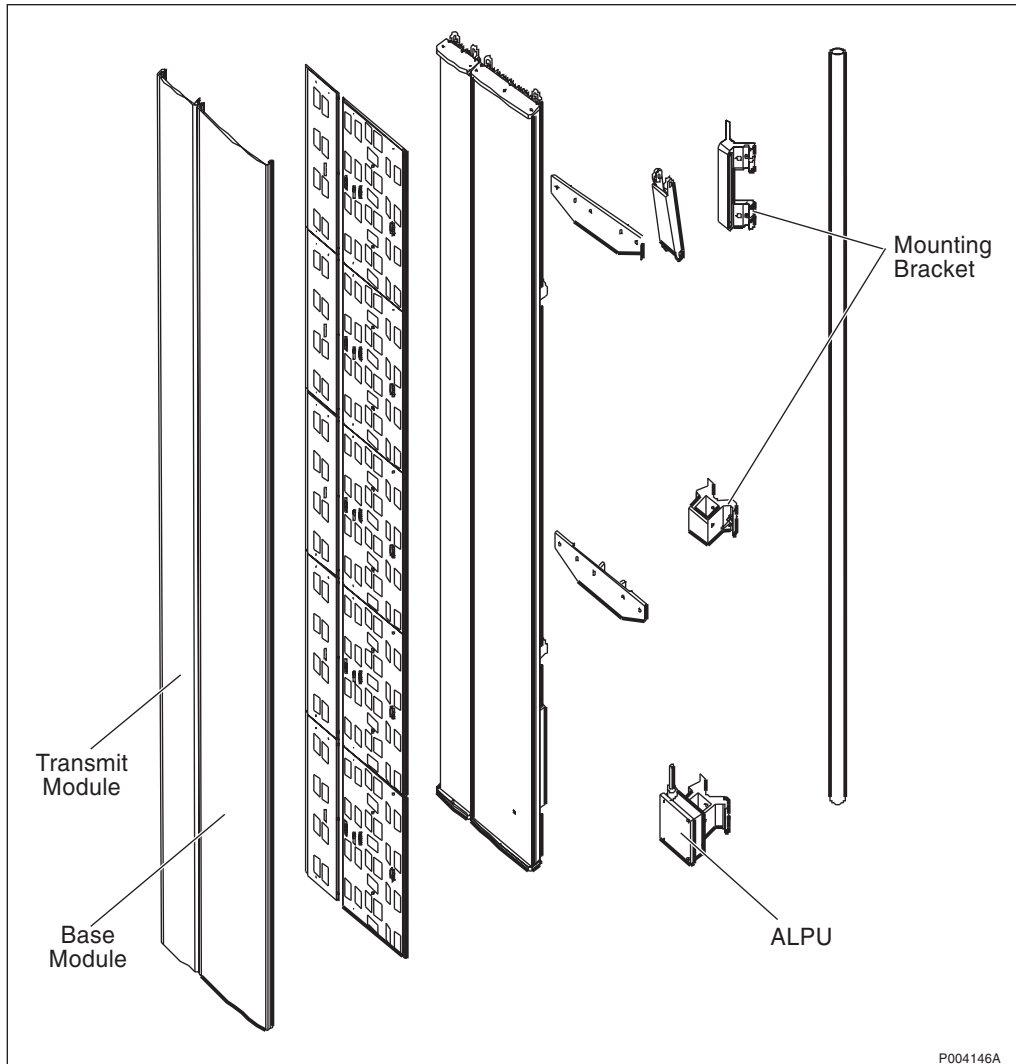

Figure 72 1250 W AAU with mounting bracket and ALPU

14.3.1 Main Physical Units, GSM 1900 (1250 W)

| | |
|------------------|------------------------------------|
| Mounting bracket | Physically mounts AAU to pole. |
| AAUs | Antenna Active Units |
| ALPU | Antenna Lightning Protection Unit |
| End cover | Covers the upper part of the AAUs. |

14.4 Configurations

14.4.1 Options

The AAUs 1250 W are flexible products and can be ordered according to the table below:

Table 31

| GSM 1900 | Frequency Band | |
|--------------------|-----------------------|-------------|
| | RX | TX |
| Band A, D (20 MHz) | 1850 - 1870 | 1930 - 1950 |
| Band B, E (20 MHz) | 1870 - 1890 | 1950 - 1970 |
| Band C, F (20 MHz) | 1890 - 1910 | 1970 - 1990 |

14.4.2 Variants

As a recommended option a higher level of lightning protection can be ordered as a separate ALPU (Antenna Lightning Protection Unit). The AAU contains a nominal amount of protection internal to the module.

14.5 Interface and Connection

14.5.1 External Connections

RF Connector

The AAUs have two duplex RF ports which are located on the bottom end of the AAUs.

| | |
|----------------------------|------------------------------|
| Type of connectors: | 7/16 female |
| The connectors are marked: | DX2: TX1/RXA DX2: TX2/RXB |
| Input power level: | +33.3 to -12.5 dBm |

Earthing

The central earth terminal is a threaded M8 stud.

DC and Alarm/Data Interfaces

The AAUs have a common port for DC power and alarm/data.

The connector type is a circular 6-pin filter connector: AAU Side – RPT 228 910/01 (ITT Cannon 192993–2013) ¹⁾

¹⁾ In the ITT Cannon number there are no pins or sockets.

| Contact | Signal name | Description |
|----------------|--------------------|-------------------------|
| DC data A | DC_-48 V | -48 V from the PBC |
| DC data C | DC_-48 V_RTN | -48 V return to the PBC |
| DC data B | RS485_A | Data |
| DC data D | RS485_B | Data |
| DC data F | RS485_SHIELD | Signal Shield |
| DC data E | ALPU alarm | - |

14.5.2 Operator Interface

The AAU alarms and attenuator values are transported to the PBC where the MMI is located. All types of alarms are displayed in the PBC. The alarms are not viewable at the AAU.

Barcode Sign

The Barcode Sign for product identification is readable without disturbing the AAUs function.

14.6 Product Requirements

14.6.1 Appearance

Ericsson products are designed to appear as one physical unit, inconspicuous, pleasant and good-looking. The colour of the AAUs is grey. The Radome is possible to paint in different colours according to Ericsson instructions.

14.6.2 Alarm

The alarm/data link communicates with the PBC and returns alarm signals and attenuator parameter settings from the AAUs. It receives commands from the PBC.

Alarm Description

Failures in the AAUs are categorized and reported to the PBC as either WARNING or SEVERE, see below.

WARNING — an error has occurred that either

- decreases the EIRP output level by less than 3 dB
- decreases RX sensitivity by less than 3 dB
- indicates loss of one of the two redundant power supplies

SEVERE— an error has occurred that either

- decreases the EIRP output level by more than 3 dB
- decreases RX sensitivity by more than 3 dB
- indicates loss of both redundant power supplies

The following alarms are reported to BSC via the PBC:

- TX1 warning
- TX1 severe
- TX2 warning
- TX2 severe
- RXA warning
- RXB warning

Note: If both the RXA and RXB indicate a warning in the PBC, a severe fault is reported to the RBS.

Failure Impact, GSM 1900 (1250 W)

The impact on site traffic due to unit failure in the AAUs is shown in the table below.

Table 32 Failure Impact

| Unit(s) failing internal to AAU | Impact on site traffic | Warning (W) or Severe (S) |
|---------------------------------|------------------------|---------------------------|
| 1 PA in one TX path | < -3 dB EIRP one side | W |
| 2+ PA in one TX path | > -3 dB EIRP one side | S |
| 1-3 LNA(s) RXA or RXB | < -3 dB RX sensitivity | W |
| 1 LNA RXA and 1 LNA RXB | <-3 dB RX sensitivity | W |
| 1 LNA RXA/B and 2 LNAs RXB/A | <-3 dB RX sensitivity | W |
| 1 LNA RXA/B and 3+ LNAs RXB/A | > -3 dB RX sensitivity | S |
| 2+ LNA RXA and 2+ LNA RXB | > -3 dB RX sensitivity | S |
| 1 DC/DC, TX-module | None | W |
| Both DC/DC, TX-module | No traffic TX2 | S |
| 1 DC/DC, Base module | None | W |
| Both DC/DC, Base module | No traffic | S |

Note: X+ means X or more, for example 2+ means 2, 3, 4... and so on.

14.6.3 Failure Report

The AAUs log and store failure indications of PAs, LNAs and DC/DC converters in a non-volatile memory. With additional diagnostic tools, it is possible to read individual fault indications which remain even after the power supply is switched off.

14.6.4 Mechanical Structure

Replaceable Units

The AAUs system consist of the following replaceable units:

- AAU (base or transmit module)
- Mounting bracket
- Antenna Lightning Protection Unit (ALPU)
- ALPU internal circuit card

Labels

All labels required for identification of the product and its compliance are readable external to the AAU.

14.6.5 Dimension and Weight

Size

(HxWxD): 2560 x 560 x 130 mm

Weight

Total weight for the AAUs: 77 kg

14.6.6 Hardware Characteristics

Acoustic Noise

The AAUs will not contribute to the acoustic noise in the surroundings.

Vandal Resistance

The AAUs will appear vandal resistant and unauthorized intrusion will not be possible without physically damaging the unit.

Packaging Material

The packaging material is reuseable.

Handling Robustness

The AAUs are designed to endure being placed on the ground during installation and maintenance work. While resting on the ground, it is important not to place the AAUs on the Radome or directly on the external connectors.

14.6.7 Radio Requirements for GSM 1900 (1250 W)

In order to balance 1250 W EIRP at 1900 MHz the Power Amplifiers, the Low Noise Amplifiers and the antenna panels are integrated in one physical unit or module.

Aperture for GSM 1900 (1250 W)

| | |
|--|-------------------------------------|
| Azimuth beam width (both TX and RX): | 55-70° at -3dB 110-135° at -10dB |
| Vertical beam width | > 3.3° |
| Polarization (relative to vertical plane) RX: | linear 0°, 90° |
| Polarization (relative to vertical plane) TX: | linear 0° |
| Cross polarization ($\pm 60^\circ$ in the polarity planes): | -12 dB (min.) |
| Co-polar radiation pattern (in the horizontal plane from channel A to channel B, $\pm 60^\circ$): | 2 dB (max.) |

| | |
|--|--|
| Front-to-back ratio in the 90° backward sector (180°±45°) in the horizontal plane and front-to-back ratio in the 40° backward sector (180°±20°) in the vertical plane: | -20 dB (min.) |
| Max. beam squint: | < 6° (horizontal plane) < 1° (vertical plane) |
| Receive diversity channel pattern matching | 1 dB |

Link Budget for GSM 1900 (1250 W)

Note: The values stated below are cell planning values.

Downlink

| | |
|-----------------|-------------|
| BS Output Power | 61 dBm EIRP |
| MS Sensitivity | -104 dBm |
| <hr/> | |
| Path Loss | 165 dB |

Uplink

| | |
|-------------------|-------------|
| MS Output Power | 30 dBm EIRP |
| BS Antenna Gain | 21 dBi |
| BS Sensitivity | -110 dBm |
| BS Diversity Gain | 3.5 dB |
| <hr/> | |
| Path Loss | 164.5 dB |

14.6.8 Environment

Operation

The AAUs are designed to endure the requirements stated in chapter Outdoor Mast Mounted Equipment.

Temperature range: -33° to +45°C

Solar Radiation

The AAUs are designed to withstand the additional heat from solar radiation in its specified environment.

Transport

The AAUs meet the following transport requirement.

Temperature range: -40°C to +70°C

Storage

The AAUs meet the following storage requirement.

Temperature range: -25°C to +55°C

Handling

The AAUs meet the following requirement for handling. This also applies to the handling of RBS parts during installation and maintenance.

Temperature range: -40°C to +70°C

14.6.9 Climate Protection

The AAU is passively cooled via chassis colling fins.

Ingression

The AAUs fulfil the IP-55 requirements according to the standard IEC 529 and type 3R according to UL50.

14.6.10 Power Supply

DC Supply Voltage

DC level -38 V to -60 V

The AAUs are designed to perform a start up after a long power failure.

Power Consumption

Maximum power consumption: 280 W (both base transmit modules transmitting on full RF output power)

14.6.11 Type Approval

Type Approval Standard

The AAU fulfils the FCC, industry Canada, UL & C-UL equipment authorizations and the GSM standards set for in JTC-J-Std-007.

14.6.12 Dependability

Technical Lifetime

The AAUs are designed for a technical lifetime of 20 years (24 hours operation).

Preventive Maintenance

The AAUs have the following dependability performance.

| Action | Interval |
|-----------------------------------|--------------|
| Mean repair time (MRT) | < 30 minutes |
| Mean time between failures (MTBF) | 17 years |
| Mean accumulated down time (MADT) | |

No preventive maintenance is needed during the lifetime of the AAUs.

14.6.13 Installation

A quick and easy installation procedure is provided. A minimum of tools and instruments are required when installing an RBS.

Installation Features

- The mounting fixture is made so that the AAUs can be replaced at site without any mechanical adjustment, that is tilt angle and azimuth direction.
- It is possible to install the AAUs on conventional one-three sector installations on poles, walls or masts.
- It is possible to mechanically adjust the down tilt 0°-10°.
- It is possible to locate the AAUs 0–100 m from the RBS/PBC with a max. RF feeder loss of 12 dB.
- No special installation material is required for the MAXITE configuration in comparison with a normal macro site.

RF Calibration Scenario

The AAU self-calibrates upon command, accounting for up to 12 dB feeder loss.

Site Installation

When installing more than one AAU at the same site, the AAUs must be separated. The following distance is recommended to provide sufficient working space.

- Min. separation 0.2 m side by side
- Min. separation 0.2 m above/below
- Min. separation 0.2 m back to back

Repair

A faulty active antenna must be replaced by a functional antenna. No repair will be performed at site.

14.6.14 Production

See the ordering information plan.

This page is intentionally left blank

15 Product Specification for Coverage Extension Unit

This chapter describes the architecture and specifies the characteristics and performance of the Coverage Extension Unit (CEU).

15.1 Terminology

| | |
|----------|--|
| ARP | Antenna Reference Point |
| CEU | Coverage Extension Unit The CEU consists of a single module containing two transmit paths and two receive paths which include integrated power amplifiers and low noise amplifiers. The CEU does not contain any passive antenna. |
| MAXITE™ | MAXITE™ is a complete package for a radio site for GSM 900, 1800 and 1900. MAXITE consists of RBS 2302, a Power and Battery Cabinet and Active Antenna Unit for GSM 1800/1900, and Coverage Extension Unit plus Passive Antenna for GSM 900. |
| MMI | Man-Machine Interface |
| PBC | Power and Battery Cabinet The PBC comprises an AC/DC converter for the AAU/CEU, -48 V, and battery, DC/DC (+24 V) for battery backup of the RBS 2302 and communication interface to the AAU/CEU. Alarms originated in the AAU/CEU or the PBC are converted and transferred to the RBS 2302 external alarm ports. Physically speaking the unit looks like the RBS 2302. |
| RBS 2302 | RBS 2302 is the second generation of GSM micro base station. |
| RBS ARP | Feeder connector on the RBS 2302 |

15.2 General

The CEU together with the RBS 2302 and PBC is a new base station concept called MAXITE 900 for the Ericsson GSM system. MAXITE 900 is designed for quick and flexible installation on poles, masts or walls and provides maximum coverage area at a low cost.

The main advantages with MAXITE are:

- Increased coverage

- Landlord friendly
- High reliability
- Low cost for the operator
- Small size
- Low weight
- Low power consumption
- Quick and easy installation
- Quick and accurate repair

The CEU consists of a single module containing two TX and two RX paths and complies with the applicable parts of the GSM specifications.

15.2.1 MAXITE™

The CEU is normally placed close to the passive antenna.

The CEU and passive antenna provide a high EIRP in comparison to its size. A high EIRP and an easy placement is very useful for a fast extension of the network.

The MAXITE site is more discreet than the traditional macrobase site and the power consumption is much lower than for the macrobase site.

15.3 Product Architecture - Main Physical Units, GSM 900

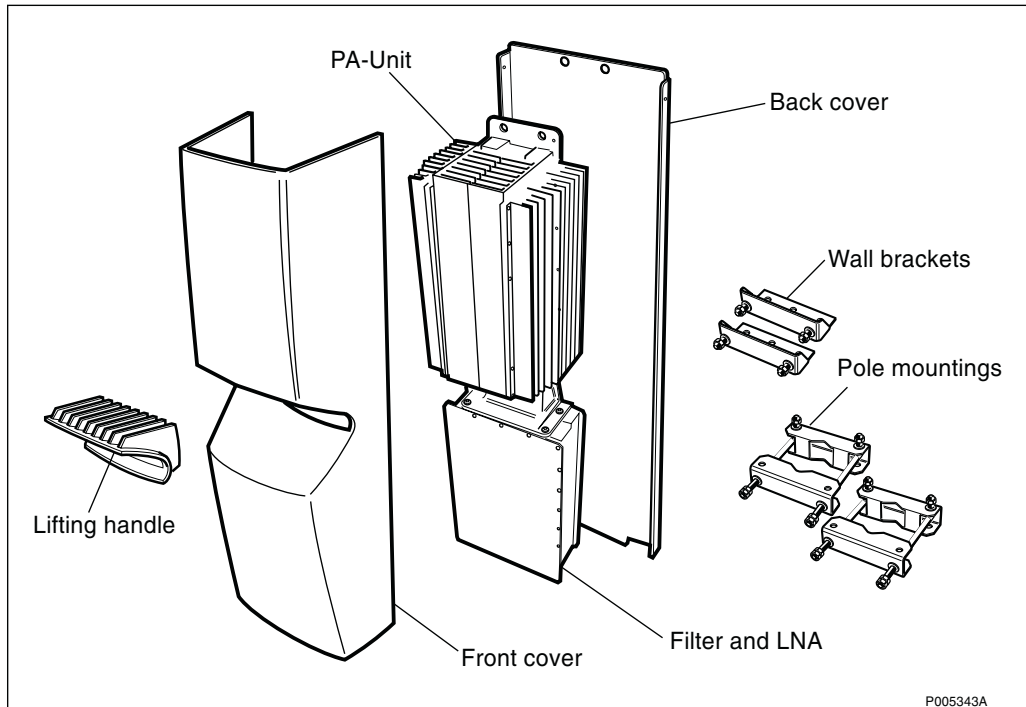

Figure 73 CEU, GSM 900

Back Cover

Covers the rear of the CEU.

| | |
|------------------|---|
| Front Cover | Covers the front of the CEU and acts as a sun-shield. |
| Filter and LNA | This unit comprises the filters and the Low Noise Amplifiers. |
| Lifting handle | Is required for easy handling of the CEU. |
| Mounting fixture | Pole mountings (optional) or upper and lower wall brackets (optional) |
| PA-Unit | Power Amplifier Unit |

15.3.1 Configurations

See *Binder Section Site Planning and Production Data* in *Maxite™ User's Guide*.

Options

Combinations of possible variants and options are specified according to *Ordering Information*.

Variants

As an option, a higher level of lightning protector can be ordered.

15.3.2 Combinations

Not applicable.

15.3.3 Interface and Connection on the CEU

External Connections

- RF connector
- RBS RF ports (ports between the CEU and RBS)

Type of connectors: N-female

The connectors are marked: TRX1 and TRX2.

Input power level: +33.3 to -5 dBm

The CEU has four duplex RF ports (two to the RBS and two to the antenna). They are located at the bottom end of the CEU.

Antenna RF Ports (Ports between CEU and Antenna)

Type of connectors: 7/16" female

The connectors are marked: ANT1 and ANT2.

Output power level: 41 ±2 dBm at max. power level

Earthing

The central earth terminal is made from a threaded M8 screw.

DC and Alarm/Data Interfaces

The CEU has common port for DC power and alarm/data.

The connector type is a D-subtype connector: CEU Side - RPT 403 810/001 (ITT Canon DSM-17H2PJ-K87).

In the Canon number there are no pins or sockets.

| Marking | Signal name | Description |
|---------|--------------|-------------------------|
| A2 | DC_-48 V | -48 V from the PBC |
| A1 | DC_-48 V_RTN | -48 V return to the PBC |
| 1 | RS485_A | Data |
| 8 | RS485_B | Data |

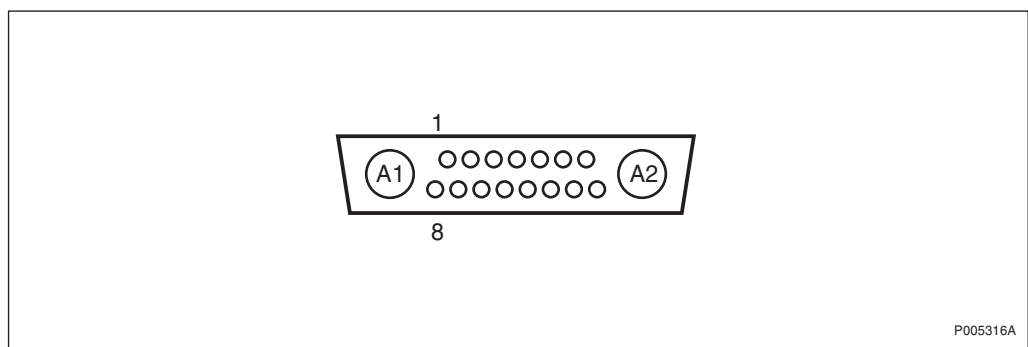

Figure 74 DC/Data connector view from mating side

The outer shield and the RS485 shield of the DC/Data cable are connected to the connector housing at the cable inlet.

Operator Interface

The CEU is a sealed unit and normally situated high up, and therefore all alarms and attenuator values are transported to the PBC where the MMI is located. All types of alarms are displayed in the PBC.

Barcode Sign

The Barcode Sign for product identification is readable without disturbing the CEU function.

15.3.4 Product Requirements

Appearance

Ericsson products are designed to appear as one physical unit, inconspicuous, pleasant and good-looking. The standard colour of the CEU is grey. The Sun-shield is possible to paint in different colours according to Ericsson instructions.

Alarm

The alarm/data link communicates with the PBC and it transfers alarm signals and attenuator parameter settings from the CEU as well as it receives a command from the PBC to set the attenuator.

Alarm Description

Failures in the CEU are categorized and reported to the PBC as either WARNING or SEVERE, see below.

WARNING - an error has occurred:

- one PA failing, second PA enabled: no impact on traffic
- < 6 dB loss in one RX carrier implies less than 3 dB loss (diversity)

SEVERE - an error has occurred:

- both PAs (in one branch) fail
- > 6 dB loss in one RX carrier implies more than 3 dB loss (diversity)
- indicates loss of a DC/DC converter
- at overtemperature

The following alarms are reported to BSC by the PBC:

- CEU warning
- TX1 or RXA severe
- TX2 or RXB severe

Note: If both the RXA and RXB indicate a warning in the PBC, they or the DC/DC converter automatically report a severe fault to the RBS.

Failure Impact

The following table shows the impact on site traffic when a unit is failing in the CEU.

Table 33 Failure impact

| Unit(s) Failing in CEU | Impact on Site Traffic | Class 2 (Warning) Class 1 (Severe) |
|-----------------------------|------------------------|---------------------------------------|
| 1st PA failing, 2nd enabled | No impact | Warning |
| Both PAs fail | No traffic | Severe |
| 1 LNA RXA or RXB | < 6 dB / <3 dB * | Warning |
| 1 LNA RXA and RXB | < 6 dB / <6 dB * | Severe |
| 2 LNA RXA or RXB | ∞ dB / <3 dB * | Severe / Warning |
| 2 LNA RXA and 1 LNA RXB | ∞ dB / <3 dB * | Severe |
| 2 LNA RXA and 2 LNA RXB | ∞ dB / <3 dB * | Severe |
| DC/DC exceeds SW limits | No impact | Warning |
| DC/DC fails | No traffic | Severe |

* The options are dependent of site configuration with the diversity case to the right.

Failure Report

The CEU logs and stores failure indications from PAs, LNAs and DC/DC converters in a non-volatile memory. This option mainly supports repair service.

Mechanical Structure

Replaceable Units

The replaceable units are the CEU, the wall brackets or the pole mounting fixtures.

Labels

All signs needed for identification of the product and its compliance are readable without disturbing the RBS function.

Dimension and Weight

Size

(HxWxD): 905x245x182 mm (excluding mounting fixtures)

Weight

The total weight is the sum of the following units:

| | |
|------------------|-------------|
| CEU | 20.5 kg |
| Mounting fixture | 2 x 1.2 kg |
| Wall bracket | 2 x 0.45 kg |

Hardware Characteristics

Acoustic Noise

The CEU will not contribute to the acoustic noise in the surroundings.

Vandal Resistance

The CEU will appear as vandal resistant, and unauthorized intrusion will not be possible without damaging the unit.

Packaging Material

The packaging material is recyclable.

Handling Robustness

The CEU is designed for intermediate placing on the ground during installation and maintenance work.

No connectors protrude outside the external dimensions.

Radio Requirements for GSM 900**Link Budget**

Note: The values stated below are cell planning values. The values are given with a 17 dBi X polarization antenna.

Downlink

| | |
|------------------------------|----------|
| BS Output Power | 41 dBm |
| BS Antenna Gain | 17 dBi |
| MS Sensitivity | -104 dBm |
| BS Feeder Loss (CEU-Antenna) | -1.0 dB |
| BS Slant Loss | -1.5 dB |
| <hr/> | |
| Path Loss | 159.5 dB |

Uplink

| | |
|-------------------|-------------|
| MS Output Power | 33 dBm EIRP |
| BS Antenna Gain | 17 dBi |
| BS Sensitivity | -110 dBm |
| BS Feeder Loss | -1 dB |
| BS Diversity Gain | 3.5 dB |
| <hr/> | |
| Path Loss | 162.5 dB |

Environment**Operation**

The CEU is designed to endure the requirements stated in *Chapter Environmental Capabilities, Section Operation Mast Mounted Equipment -33 °C - +55 °C*.

Solar Radiation

The CEU is designed to withstand the additional heat from solar radiation in its specified environment.

Transport -40 °C - +70 °C

See *Chapter Environmental Capabilities*.

Storage -25 °C - +55 °C

See *Chapter Environmental Capabilities*.

Handling -40 °C - +70 °C

See *Chapter Environmental Capabilities*.

Climate Protection

Climate Protection Principle

The climate protection maintains the internal temperature within the allowed range for the units in the CEU.

If the temperature exceeds the limits, the CEU switches off so that the CEU is not damaged. When the temperature returns within the limits, the CEU switches on again.

The climate protection of the CEU is handled by a combination of natural convection with the help of cooling fins.

Ingression

The CEU fulfils the IP-55 requirements according to the standard IEC 529 and type 3R according to UL50.

Power Supply

DC Supply Voltage

| | |
|----------|------------------|
| DC level | -36.3 V to -60 V |
|----------|------------------|

The CEU is able to perform a start up after a long power failure.

Power Consumption

| | |
|----------------------------|---|
| Maximum power consumption: | 240 W (both TRXs transmitting on full output power) |
|----------------------------|---|

Type Approval

Type Approval Standard

The CEU fulfils the required type approvals from GSM 11.20 or GSM 11.21 standard. According to requirements in *Chapter Product Specification of RBS 2302*.

EMC

The CEU complies with the European Community market requirements regarding EMC for ancillary RF amplifier. The product has the CE sign to show this compliance.

Dependability

Technical Lifetime

The CEU is designed for a technical lifetime of 20 years (24 hours operation).

Preventive Maintenance

The CEU has the following dependability performance.

| Action | Interval |
|-----------------------------------|---|
| Mean repair time (MRT) | < 30 minutes |
| Mean time between failures (MTBF) | 25 years |
| Mean accumulated down time (MADT) | < 1.2 minutes/year (time to reach the site is not included) |

No preventive maintenance is needed under the lifetime of the CEU.

Installation

A quick and easy installation procedure is provided. A minimum of tools and instruments are required when installing a MAXITE 900.

Installation Features

- The mounting fixture is made so that the CEU can be replaced at site without any mechanical adjustment.
- It is possible to install the CEU on conventional one-three sector installations on poles, walls or masts.
- A temporary lifting device can be attached during installation.
- It is possible to locate the CEU 0–100 m from the RBS/PBC with a max. feeder loss of 9.0 dB.
- No special installation material is required for the MAXITE 900 configuration in comparison with a normal macro site.
- It is possible to expand the CEU in the MAXITE 900 concept with up to three CEUs/sector (6 TX channels).

Installation Scenario

At installation, the CEU measures the attenuation between the RBS and the CEU and calculates an attenuator setting. This setting is stored in a non-volatile memory in the CEU and the variable attenuator in the CEU is set to a value with a resolution of ± 0.25 dB in each transmit/receive branch.

Site Installation

When installing more than one CEU at the same site, the CEUs must be separated. The following separation is recommended to provide sufficient working space.

- Min. separation 0.2 m side by side
- Min. separation 1 m above/below
- Min. separation 0.2 m back to back

Repair

A faulty CEU must be replaced by a functional CEU. No repair will be performed at site. In the CEU, all active subunits report faults to a flash memory. At a repair centre the faults can be logged on a fault report making it easier to detect the faulty unit/s.

Production

The concept for the RBS supports production according to customer choice from the ordering information plan.

16 EMC Capabilities for RBS 2301

This chapter covers the capabilities of the RBS 2000 in respect of EMC (ElectroMagnetic Compatibility). The capabilities include conducted and radiated emission as well as conducted and radiated immunity thresholds.

16.1 References

1. 89/336/EEC EMC directive
Council directive of 3 May 1989 on approximation of laws of the Member States relating to electromagnetic compatibility.
2. ETS 300 342-2, Nov 1994
EMC for European digital cellular telecommunication (GSM) mobile radio and ancillary equipment.
3. EN 55 022, April 1987
Limits and methods of Measurement of Radio Interference Characteristics of Information Technology Equipment.
4. EN 50 081-1, January 1992
Electromagnetic compatibility - Generic emission standard, Part 1: Residential, commercial and light industry.
5. EN 50 082-1, January 1992
Electromagnetic compatibility - Generic immunity standard, Part 1: Residential, commercial and light industry.
6. IEC 801-3, 1984
Radiated electromagnetic field requirement.
7. IEC 1000-3-2, EMC part 3, section 2
limits for harmonic current emissions, 1995
8. IEC 1000-3-3, EMC part 3, section 2
limitation of voltage fluctuations and flicker in low-voltage supply systems for equipment with rated current <16 A, 1994.
9. IEC 1000-4-2, 1995
Electrostatic discharge requirements.
10. IEC 1000-4-4, 1995
Electrical fast transient/burst requirement.
11. IEC 1000-4-5
Surge Immunity Requirements.
12. IEC 1000-4-8, 1993
Power frequency magnetic field immunity tests.
13. IEC 1000-4-11

Voltage Dips, short interruptions and voltage variations.
Immunity tests.

14. VDE 0878, 1986

Radio Interface Suppression of Telecommunication Systems and Apparatus.

15. ITU-T Recommendation K.20, 1984

Resistibility of Telecommunication Switching Equipment to Overvoltages and Overcurrents.

The following standards are equal in all matters:

| | | |
|---------------|---|---------------|
| IEC 1000-3-2 | = | EN 61000-3-2 |
| IEC 1000-3-3 | = | EN 61000-3-3 |
| IEC 1000-4-2 | = | EN 61000-4-2 |
| IEC 1000-4-3 | = | EN 61000-4-3 |
| IEC 1000-4-4 | = | EN 61000-4-4 |
| IEC 1000-4-5 | = | EN 61000-4-5 |
| IEC 1000-4-8 | = | EN 61000-4-8 |
| IEC 1000-4-11 | = | EN 61000-4-11 |

16.2 Concepts

External signal line - outdoor systems

Cable or lead longer than 1 meter intended for connection to units located outside the cabinet.

Telecommunication line

Cable intended for connection to a public network.

Enclosure Port

The physical boundary of the RBS through which electromagnetic fields may radiate or impinge.

Performance Criteria A

The system shall continue to operate as intended. During the test, no degradation of performance or loss of function is allowed below the specified test level.

Performance Criteria B

The system shall continue to operate as intended after the test. During the test, degradation of performance is however allowed below the specified test level. No change of actual operating state or stored data is allowed.

Performance Criteria C

Temporary loss of function is allowed, provided the function is self-recoverable

or can be restored by the operation of the controls.

| | |
|-------------------------------|---|
| Performance Criteria CT | Continuous phenomena applied to Transmitters. A communication link shall be established at the start of the test and maintained during the test. For the system the RXQUAL (as defined in GSM 05.08) of the downlink shall not exceed three, measured during each individual exposure in the test sequence. |
| Performance Criteria TT | Transient phenomena applied to Transmitters. A communication link shall be established at the start of the test and maintained during and after injection of the transients. |
| Performance Criteria CR | Continuous phenomena applied to Receivers. A communication link shall be established at the start of the test and maintained during the test. For the system the RXQUAL (as defined in GSM 05.08) of the uplink shall not exceed three, measured during each individual exposure in the test sequence. |
| Performance Criteria TR | Transient phenomena applied to Receivers. A communication link shall be established at the start of the test and maintained during and after injection of the transients. |
| Performance Criteria A(K.20): | The test object shall withstand the test without damage or other disturbances after the test. |
| Performance Criteria B(K.20): | A fire hazard should not arise in the test object. Any damage or permanent malfunction occurring should be confined to a small number of external line interface circuits. |

16.3 Capabilities

16.3.1 RBS Description

Hardware

The capabilities are tested for an RBS equipped with a minimum representative configuration of units. This system is representative of installed systems in terms of function, which includes at least one of each function unit type, and electromagnetic radiation characteristics.

The number and types of sub-units are given from results of investigations in accordance with ETS 300 342-2, Nov 1994.

Software

The capabilities are valid for a standard setup of system software with default parameters.

Performance

For the immunity capabilities the RBS is operating and will fulfil the performance criteria stated for each test.

For emission capabilities all equipment in the RBS was enabled during verification to create the worst emission case.

EMC directive

The EMC capabilities of the RBS fulfills the mandatory requirements specified in the EMC directive, 89/336/EEC, which gives compliance for trade in EU member countries.

Generic Standards

The following generic standards are fulfilled by the system:

EN 50 081–1, Jan 1992 Emission

EN 50 082–1, Jan 1992 Immunity

16.3.2 Conducted Emission

Table 34 Voltage fluctuation on AC power supply leads

| | |
|----------------|---------------------------------|
| Basic standard | IEC 1000-3-3 |
| Limit | Set by Table II in IEC 1000-3-3 |

Table 35 Harmonics on AC power supply leads

| | |
|----------------|--------------------------------|
| Basic standard | IEC 1000-3-2 |
| Limit | Set by Table 1 in IEC 1000-3-2 |

Table 36 Interference on AC power supply leads

| | |
|----------------|-----------|
| Basic standard | EN 55 022 |
| Limit | Class B |

| | |
|----------------|--------------------------------------|
| Limit standard | VDE 0878, Conducted emission, part 1 |
| Limit | Class B |

Table 37 Interference on DC power supply leads

| | |
|----------------|--|
| Basic standard | EN 50 022 and proposed amendment to CISPR 22 |
| Limit | Class B |

| | |
|----------------|-------------------------|
| Limit standard | ETS 300 342-2, Nov 1994 |
| Limit | Class B |

Table 38 Interference on signal and telecommunication lines

| | |
|----------------|----------------------------|
| Basic standard | CISPR/G(sec) December 1993 |
|----------------|----------------------------|

16.3.3 Radiated Emission from Enclosure

Table 39 Electric field emission

| | |
|----------------|-----------|
| Basic standard | EN 55 022 |
| Limit | Class B |

Table 40 Magnetic field emission

| | |
|----------------|-------------------------------------|
| Limit standard | VDE 0878, Magnetic emission, part 1 |
| Limit | Class B |

16.3.4 Conducted Immunity on AC Input Power Ports

Table 41 Fast transient test

| | |
|----------------|---|
| Basic standard | IEC 1000-4-4 |
| Test level | 6 kV common mode between all lines and cabinet ground reference |
| Performance | Criteria B |

| | |
|----------------|---|
| Limit standard | ETS 300 342-2 |
| Test level | 6 kV common mode between all lines and cabinet ground reference |
| Performance | Criteria A for a complete system Criteria TT for transmitter units Criteria TR for receiver units |

Table 42 Surge test

| | |
|----------------|--|
| Limit standard | ETS 300 342-2 |
| Test level | 6 kV common mode between all lines and cabinet ground reference ¹⁾ 6 kV differential mode, between line and line |
| Performance | Criteria A for a complete system Criteria TT for transmitter units Criteria TR for receiver units |

¹⁾ System primary protected

Table 43 RF common mode test

| | |
|----------------|---|
| Limit standard | ETS 300 342-2 |
| Test level | 10 V(rms) |
| Performance | Criteria A for a complete system Criteria CT for transmitter units Criteria CR for receiver units |

Table 44 Voltage dips and interruptions on AC ports

| | |
|----------------|----------------------------------|
| Basic standard | IEC 1000-4-11 |
| Performance | Criteria A for a complete system |

16.3.5 Immunity on Telecommunication and External Signal Lines

Table 45 Fast transient test

| | |
|----------------|--|
| Basic standard | IEC 1000-4-4 |
| Test level | 2 kV common mode between line and cabinet ground reference |
| Performance | Criteria B |

| | |
|----------------|---|
| Limit standard | ETS 300 342-2 |
| Test level | 4 kV common mode between line and cabinet ground reference |
| Performance | Criteria A for a complete system Criteria TT for transmitter units Criteria TR for receiver units |

Table 46 Surge test 1.2/50 pulses

| | |
|----------------|--|
| Limit standard | IEC 1000-4-5 |
| Test level | 2 kV common mode between line and cabinet ground reference 1 kV differential mode between line and line |
| Performance | Criteria B for a complete system Criteria TT for transmitter units Criteria TR for receiver units |

Table 47 Surge test 10/700 pulses

| | |
|----------------|--|
| Limit standard | IEC 1000-4-5 |
| Test level | 1 kV common mode between line and cabinet ground reference 1 kV differential mode between line and line |
| Performance | Criteria B for a complete system Criteria TT for transmitter units Criteria TR for receiver units |

Table 48 Power induction test

| | |
|----------------|------------------------|
| Basic standard | ITU-T K.20 |
| Test level | 600 V(rms) common mode |
| Performance | Criteria A(K.20) |

Table 49 RF common mode test

| | |
|----------------|---|
| Limit standard | ETS 300 342-2 |
| Test level | 10 V(rms) |
| Performance | Criteria A for a complete system Criteria CT for transmitter units Criteria CR for receiver units |

16.3.6 Radiated Immunity of Enclosure Port

Table 50 Immunity of continuous electric fields

| | |
|----------------|------------|
| Basic standard | IEC 801-3 |
| Test level | 10 V/m |
| Performance | Criteria A |

| | |
|-----------------|---|
| Limit standard | ETS 300 342-2 |
| Test level | 10 V/m, 80 MHz - 1 GHz |
| Frequency range | 30 V/m, 1 GHz-20 GHz |
| Performance | Criteria A for a complete system Criteria CT for transmitter units Criteria CR for receiver units |

Table 51 Immunity of 50/60 Hz magnetic fields

| | |
|----------------|------------------|
| Basic standard | IEC 1000-4-8 |
| Test level | 10 A/m, 50/60 Hz |
| Performance | Criteria A |

16.3.7 Electrostatic Discharges

Table 52 Immunity of enclosure port

| | |
|----------------|---|
| Basic standard | IEC 1000-4-2 |
| Test level | Air discharges: 15 kV Contact discharges: 8 kV |
| Performance | Criteria B |

| | |
|----------------|---|
| Limit standard | ETS 300 342-2 |
| Test level | Air discharges: 8 kV Contact discharges: 4 kV. |

| | |
|-------------|---|
| Performance | Criteria A for a complete system Criteria TT for transmitter units Criteria TR for receiver units |
|-------------|---|

17 EMC Capabilities for RBS 2302 and Maxite™

This chapter covers the capabilities of the RBS 2302 in respect of EMC (ElectroMagnetic Compatibility). The capabilities include conducted and radiated emission as well as conducted and radiated immunity thresholds.

17.1 References

1. 89/336/EEC EMC directive
Council directive of 3 May 1989 on approximation of laws of the Member States relating to electromagnetic compatibility.
2. I-ETS 300 609–1, 1997
Digital cellular telecommunications system (Phase 2); Base Station System (BSS) equipment specification.
Part 1: Radio Aspects (GSM11.21)
3. I-ETS 300 609–4, 1997
Digital cellular telecommunications system (Phase 2); Base Station System (BSS) equipment specification.
Part 4: Repeaters (GSM11.24)
4. prETS 300 342–3, October 1997
Radio Equipment and System (RES); Electro-Magnetic Compatibility (EMC) for Digital cellular telecommunication system.
Part 3: Base station radio and ancillary equipment and repeaters meeting Phase 2 GSM requirements.
5. EN 55 022, 1993 + AM1, 1995
Limits and methods of measurement of radio disturbances characteristics of information technology equipment.
6. EN 50 081–1, 1992, Electromagnetic compatibility - Generic emission standard
Part 1: Residential, commercial and light industry.
7. EN 50 082–1, 1992, Electromagnetic compatibility - Generic emission standard
Part 1: Residential, commercial and light industry.
8. EN 61 000–3–2, 1995
Electromagnetic compatibility (EMC)
Part 3: Limits
Section 2: Limits for harmonic current emissions (equipment input current < 16 A per phase)
9. EN 61 000–3–3, 1995

- Electromagnetic compatibility (EMC)
Part 3: Limits
Section 2: Limits for voltage fluctuations and flicker in low-voltage supply systems for equipment with current <16 A.
- 10. EN 61 000-4-2, 1995
Electromagnetic compatibility (EMC)
Part 4: Testing and measurement techniques
Section 2: Electrostatic discharge immunity test
- 11. EN 61 000-4-3, 1995
Electromagnetic compatibility (EMC)
Part 4: Testing and measurement techniques
Section 3: Radiated, radio-frequency, electromagnetic field immunity test
- 12. EN 61 000-4-4, 1995
Electromagnetic compatibility (EMC)
Part 4: Testing and measurement techniques
Section 4: Electrical fast transient/burst immunity test
- 13. EN 61 000-4-5, 1995
Electromagnetic compatibility (EMC)
Part 4: Testing and measurement techniques
Section 5: Surge immunity test
- 14. EN 61 000-4-6, 1995
Electromagnetic compatibility (EMC)
Part 4: Testing and measurement techniques
Section 6: Immunity to conducted disturbances, induced by radio frequency fields
- 15. EN 61 000-4-8, 1994
Electromagnetic compatibility (EMC)
Part 4: Testing and measurement techniques
Section 8: Power frequency magnetic field immunity test, Basic EMC Publication
- 16. EN 61 000-4-11, 1994
Electromagnetic compatibility (EMC)
Part 4: Testing and measurement techniques
Section 11: Voltage dips, short interruptions and voltage variations immunity tests

17. IEC 801-2, 1984
Electromagnetic compatibility (EMC) for industrial-process measurement and control equipment
Part 2: Electrostatic discharge requirements
18. IEC 801-3, 1984
Electromagnetic compatibility (EMC) for industrial-process measurement and control equipment
Part 3: Radiated electromagnetic field requirement
19. IEC 801-4, 1988
Electromagnetic compatibility (EMC) for industrial-process measurement and control equipment
Part 4: Electrical fast transient/burst requirement
20. IEC 1312–3, 1994
Protection against Lightning Electromagnetic Impulse
Part 3: Requirements of surge protective devices
21. ITU-T Recommendation K.20, 1993
Resistibility of Telecommunication Switching Equipment to Overvoltages and Overcurrents.
22. CISPR 16–1, 1993
Specification for Interferences Measuring Apparatus and Measuring Methods
Part 1: Radio disturbance and immunity measuring apparatus
23. Code of Federal Regulations title 47
FCC part 24
Personal Communications Services
24. Code of Federal Regulations title 47
FCC part 2
Frequency allocations and radio treaty matters, General rules and regulations
25. Code of Federal Regulations title 47
FCC part 15
Radio Frequency devices

17.2 Concepts

| | |
|----------------------|--|
| External signal Port | Cable or lead intended for connection to units located outside the Radio Base System without connection to a public network. |
|----------------------|--|

| | |
|----------------------------|--|
| Telecommunication Port | Cable or lead intended for connection to a public network. |
| Enclosure Port | The physical boundary of the test unit through which electromagnetic fields may radiate or impinge. |
| Performance Criteria A | The unit shall continue to operate as intended. During the test, no degradation of performance or loss of function is allowed below the specified test level. |
| Performance Criteria B | The system shall continue to operate as intended after the test. During the test, degradation of performance is however allowed below the specified test level. No change of actual operating state or stored data is allowed. |
| Performance Criteria C | Temporary loss of function is allowed, provided the function is self-recoverable or can be restored by the operation of the controls. |
| Performance Criteria CT | Continuous phenomena applied to Transmitters. A communication link is established at the start of the test and maintained during the test. |
| Performance Criteria TT | Transient phenomena applied to Transmitters. A communication link must be established at the start of the test and maintained during and after injection of the transients. |
| Performance Criteria CR | Continuous phenomena applied to Receivers. A communication link must be established at the start of the test and maintained during the test. |
| Performance Criteria TR | Transient phenomena applied to Receivers. A communication link must be established at the start of the test and maintained during and after injection of the transients. |
| Performance Criteria CRptr | Continuous phenomena applied to Ancillary RF amplifiers. The gain measured during the test must not change from the gain measured before the test by more than 1 dB. During the test no degradation of performance or loss of function is allowed. |
| Performance Criteria TRptr | Transient phenomena applied to Ancillary RF amplifiers. The gain measured after the test must not change |

from the gain measured before the test by more than 1 dB. During the test no degradation of performance or loss of function is allowed.

Performance Criteria A(K.21): The test object must withstand the test without damage or other disturbances after the test.

Performance Criteria B(K.21): A fire hazard should not arise in the test object. Any damage or permanent malfunction occurring should be confined to a small number of external line interface circuits.

17.3 Emission

17.3.1 Conducted Emission, Interference on AC Power Supply Ports

RBS 2302

Table 53 Fulfills EEC type approval certification requirements according to:

| | |
|------------------|-------------------------------|
| Product standard | prETS 300 342-3, October 1997 |
| Basic standard | EN 55 022, 1994 |
| Limit | Class B |

Table 54 Fulfills FCC type approval verification requirements according to:

| | |
|----------------|-------------|
| Digital device | Non TX mode |
| Limit | Class B |

Specification references:

Code of Federal Regulations 47, FCC part 15 chapter 15.107.

PBC

Table 55 Fulfills EEC self certification requirements according to:

| | |
|------------------|-------------------|
| Generic standard | EN 50 081-1, 1992 |
| Basic standard | EN 55 022, 1994 |
| Limit | Class B |

AAU

No requirements are applicable for the AAU.

17.3.2 Conducted Emission, Interference on DC Power Supply Ports

RBS

Table 56 Fulfills EEC type approval certification requirements according to:

| | |
|------------------|-------------------------------|
| Product standard | prETS 300 342-3, October 1997 |
| Basic standard | EN 55 022, 1994 |
| Limit | Class A |

PBC

Table 57 Fulfills EEC self certification requirements according to:

| | |
|------------------|-------------------|
| Generic standard | EN 50 081-1, 1992 |
| Basic standard | EN 55 022, 1994 |
| Limit | Class A |

AAU

Table 58 Fulfills EEC type approval certification requirements according to:

| | |
|------------------|-------------------------------|
| Product standard | prETS 300 342-3, October 1997 |
| Basic standard | EN 55 022, 1994 |
| Limit | Class A |

17.3.3 Radiated Emission, Electric Field Emission

RBS

Table 59 Fulfills EEC type approval certification requirements according to:

| | |
|------------------|-------------------------------------|
| Product standard | prETS 300 342-3, October 1997 |
| Basic standard | I-ETS 300 609-1, 1997 |
| Frequency range | 30 MHz - 4 GHz |
| Operating mode | Transmitters with full output power |

PBC

Table 60 Fulfills EEC self certification requirements according to:

| | |
|------------------|-------------------|
| Generic standard | EN 50 081-1, 1992 |
| Basic standard | EN 55 022, 1994 |
| Limit | Class B |

AAU

Table 61 Fulfills EEC type approval certification requirements according to:

| | |
|------------------|-------------------------------|
| Product standard | prETS 300 342-3, October 1997 |
| Basic standard | I-ETS 300 609-4, 1997 |
| Frequency range | 30 MHz - 4 GHz |
| Operating mode | Amplifier active |

17.3.4 Radiated Emission, TX Mode**RBS**

The value of the spurious emission is at least 80 dB or $43 + 10 \cdot \log$ (mean output power in Watt), whichever the lesser, below the mean power of the unmodulated carrier.

The calculated radiated power limit for radiated emissions is -13 dBm.

Specification references:

Code of Federal Regulations 47, FCC part 2 chapter 2.993, 2.997 and FCC part 24 chapter 24.238.

17.3.5 Radiated Emission, None TX Mode**RBS**

The radiated emission limit is specified up to the frequency shown in the following table.

Table 62 Radiated emission limit

| Highest frequency generated or used in the device or on which the device operates or tunes on (MHz), Emission (MHz) | Upper frequency of measurement range (MHz) |
|---|---|
| <1.0705 | 30 |
| 1.0705 - 108 | 1000 |
| 108 - 500 | 2000 |
| 500 -1000 | 3000 |
| >1000 | 5th harmonic of the highest freq. or 40 GHz which ever is lower |

The field strength of radiated emissions does not exceed the limits in the following table at 3 m distance.

Table 63 Field strength of radiated emissions limits

| Frequency of emission (MHz) | Field strength | |
|-----------------------------|----------------|----------|
| | (uV/m) | (dBuV/m) |
| 30 - 88 | 100 | 40 |
| 88 - 216 | 150 | 43.5 |
| 216 - 960 | 200 | 46 |
| >960 | 500 | 54 |

Specification references:

Code of Federal Regulations 47, FCC part 15 chapter 15.33, 15.109.

17.4 Immunity

Note: Increased test level, extended frequency range and more severe performance criteria are specified by Ericsson internal EMC document.

17.4.1 Conducted Immunity on AC power ports

Fast Transient Test: RBS

Table 64 Fulfills the EEC type approval certification requirements according to:

| | |
|------------------|--|
| Product standard | prETS 300 342-3, October 1997 |
| Basic standard | EN 61 000-4-4, 1995 |
| Test level | 2 kV common mode between all lines and cabinet ground reference. |
| Performance | Criteria TT Criteria TR |

Note: See the first note under Section 17.4 Immunity on page 214.

Fast Transient Test: PBC

Table 65 Fulfills the EEC self certification requirements according to:

| | |
|----------------------|--|
| Generic standard | EN 50 082-1, 1992 |
| Basic standard | IEC 801-4, 1988 |
| Mandatory test level | 1 kV common mode between all lines and cabinet ground reference. |
| Performance | Criteria B |

Note: See the first note under Section 17.4 Immunity on page 214.

Fast Transient Test: AAU

No requirements is applicable for the AAU.

Surge Test: RBS

Table 66 Fulfills the EEC type approval certification requirements according to:

| | |
|------------------|--|
| Product standard | prETS 300 342-3, October 1997 |
| Basic standard | EN 61 000-4-5, 1995 |
| Pulse shape | 1, 2/50 (8/20) us |
| Test level | 1 kV common mode between all lines and cabinet ground reference. 0.5 kV differential mode between line and line. |

| | |
|-------------|----------------------------|
| Performance | Criteria TT Criteria TR |
|-------------|----------------------------|

Note: See the first note under Section 17.4 Immunity on page 214.

Surge Test: PBC

Note: See the first note under Section 17.4 Immunity on page 214.

Surge Test: AAU

Table 67 Fulfills the EEC type approval certification requirements according to:

| | |
|------------------|--|
| Product standard | prETS 300 342-3, October 1997 |
| Basic standard | EN 61 000-4-5, 1995 |
| Pulse shape | 1, 2/50 (8/20) us |
| Test level | 1 kV common mode between all lines and cabinet ground reference. 0.5 kV differential mode between line and line. |

| | |
|-------------|----------------|
| Performance | Criteria TRptr |
|-------------|----------------|

Note: See the first note under Section 17.4 Immunity on page 214.

RF Common Mode: RBS

Table 68 Fulfills the EEC type approval certification requirements according to:

| | |
|------------------|-------------------------------|
| Product standard | prETS 300 342-3, October 1997 |
| Basic standard | EN 61 000-4-6, 1996 |
| Frequency range | 150 kHz - 80 MHz |
| Test level | 3 V(rms) |

| | |
|-------------|----------------------------|
| Performance | Criteria CT Criteria CR |
|-------------|----------------------------|

Note: See the first note under Section 17.4 Immunity on page 214.

RF Common Mode: PBC

Note: See the first note under Section 17.4 Immunity on page 214.

RF Common Mode: AAU

Table 69 Fulfills the EEC type approval certification requirements according to:

| | |
|------------------|-------------------------------|
| Product standard | prETS 300 342-3, October 1997 |
| Basic standard | EN 61 000-4-6, 1996 |
| Frequency range | 150 kHz - 80 MHz |
| Test level | 3 V(rms) |

| | |
|-------------|----------------|
| Performance | Criteria CRptr |
|-------------|----------------|

Note: See the first note under Section 17.4 Immunity on page 214.

Voltage Dips and Interruptions on AC Power Ports, RBS/ PBC/ AAU

Table 70 Fulfills the EEC type approval certification requirements according to:

| | |
|------------------|---|
| Product standard | prETS 300 342-3, October 1997 |
| Basic standard | EN 61 000-4-11, 1994 |
| Test level 1 | Voltage dip, 30% reduction of nominal voltage during 10 ms |
| Test level 2 | Voltage dip, 60% reduction of nominal voltage during 100 ms |
| Test level 3 | Voltage dip, >95% reduction of nominal voltage during 5000 ms |

| | |
|-------------|---|
| Performance | Criteria TT Criteria TR Level 1 without battery back-up Level 2 and 3 with battery back-up |
|-------------|---|

17.4.2 Conducted Immunity on DC Power Ports

Fast Transient Test: RBS

Table 71 Fulfills the EEC type approval certification requirements according to:

| | |
|------------------|--|
| Product standard | prETS 300 342-3, October 1997 |
| Basic standard | EN 61 000-4-4, 1995 |
| Test level | 1 kV common mode between all lines and cabinet ground reference. |

| | |
|-------------|----------------------------|
| Performance | Criteria TT Criteria TR |
|-------------|----------------------------|

Note: See the first note under Section 17.4 Immunity on page 214.

Fast Transient Test: PBC

Table 72 Fulfills the EEC self certification requirements according to:

| | |
|------------------|--|
| Generic standard | EN 50 082-1, 1992 |
| Basic standard | IEC 801-4, 1988 |
| Test level | 0.5 kV common mode between all lines and cabinet ground reference. |

| | |
|-------------|------------|
| Performance | Criteria B |
|-------------|------------|

Note: See the first note under Section 17.4 Immunity on page 214.

Fast Transient Test: AAU

Table 73 Fulfills the EEC type approval certification requirements according to:

| | |
|------------------|--|
| Product standard | prETS 300 342-3, October 1997 |
| Basic standard | EN 61 000-4-4, 1995 |
| Test level | 1 kV common mode between all lines and cabinet ground reference. |

| | |
|-------------|----------------|
| Performance | Criteria TRptr |
|-------------|----------------|

Note: See the first note under Section 17.4 Immunity on page 214.

Surge Test: RBS, PBC, AAU

Note: See the first note under Section 17.4 Immunity on page 214.

RF Common Mode: RBS

Table 74 Fulfills the EEC type approval certification requirements according to:

| | |
|------------------|-------------------------------|
| Product standard | prETS 300 342-3, October 1997 |
| Basic standard | EN 61 000-4-6, 1996 |
| Frequency range | 150 kHz - 80 MHz |
| Test level | 3 V(rms) |

| | |
|-------------|----------------------------|
| Performance | Criteria CT Criteria CR |
|-------------|----------------------------|

Note: See the first note under Section 17.4 Immunity on page 214.

RF Common Mode: PBC

No requirements are applicable for the PBC.

RF Common Mode: AAU

Table 75 Fulfills the EEC type approval certification requirements according to:

| | |
|------------------|-------------------------------|
| Product standard | prETS 300 342-3, October 1997 |
| Basic standard | EN 61 000-4-6, 1996 |
| Frequency range | 150 kHz - 80 MHz |
| Test level | 3 V(rms) |

| | |
|-------------|----------------|
| Performance | Criteria CRptr |
|-------------|----------------|

17.4.3 Conducted Immunity on Intra-Connecting Signal Ports

Fast Transient Test: RBS

Table 76 Fulfills the EEC type approval certification requirements according to:

| | |
|------------------|--|
| Product standard | prETS 300 342-3, October 1997 |
| Basic standard | EN 61 000-4-4, 1995 |
| Test level | 0.5 kV common mode between all lines and cabinet ground reference. |
| Performance | Criteria TT Criteria TR |

Note: See the first note under Section 17.4 Immunity on page 214.

Fast Transient Test: PBC

Table 77 Fulfills the EEC self certification requirements according to:

| | |
|------------------|--|
| Generic standard | EN 50 082-1, 1992 |
| Basic standard | IEC 801-4, 1988 |
| Test level | 0.5 kV common mode between all lines and cabinet ground reference. |
| Performance | Criteria B |

Note: See the first note under Section 17.4 Immunity on page 214.

Fast Transient Test: AAU

Table 78 Fulfills the EEC type approval certification requirements according to:

| | |
|------------------|--|
| Product standard | prETS 300 342-3, October 1997 |
| Basic standard | EN 61 000-4-4, 1995 |
| Test level | 0.5 kV common mode between all lines and cabinet ground reference. |
| Performance | Criteria TRptr |

Note: See the first note under Section 17.4 Immunity on page 214.

RF Common Mode: RBS

Table 79 Fulfills the EEC type approval certification requirements according to:

| | |
|------------------|-------------------------------|
| Product standard | prETS 300 342-3, October 1997 |
| Basic standard | EN 61 000-4-6, 1996 |
| Frequency range | 150 kHz - 80 MHz |
| Test level | 3 V(rms) |

| | |
|-------------|----------------------------|
| Performance | Criteria CT Criteria CR |
|-------------|----------------------------|

Note: See the first note under Section 17.4 Immunity on page 214.

RF Common Mode: PBC

Note: See the first note under Section 17.4 Immunity on page 214.

RF Common Mode: AAU

Table 80 Fulfills the EEC type approval certification requirements according to:

| | |
|------------------|-------------------------------|
| Product standard | prETS 300 342-3, October 1997 |
| Basic standard | EN 61 000-4-6, 1996 |
| Frequency range | 150 kHz - 80 MHz |
| Test level | 3 V(rms) |

| | |
|-------------|----------------|
| Performance | Criteria CRptr |
|-------------|----------------|

Note: See the first note under Section 17.4 Immunity on page 214.

17.4.4 Conducted Immunity on Telecommunication and External Signal Ports

Fast Transient Test: RBS

Table 81 Fulfills the EEC type approval certification requirements according to:

| | |
|------------------|--|
| Product standard | prETS 300 342-3, October 1997 |
| Basic standard | EN 61 000-4-4, 1995 |
| Test level | 0.5 kV common mode between all lines and cabinet ground reference. |

| | |
|-------------|----------------------------|
| Performance | Criteria TT Criteria TR |
|-------------|----------------------------|

Note: See the first note under Section 17.4 Immunity on page 214.

Fast Transient Test: PBC

Table 82 Fulfills the EEC self certification requirements according to:

| | |
|------------------|--|
| Generic standard | EN 50 082-1, 1992 |
| Basic standard | IEC 801-4, 1988 |
| Test level | 0.5 kV common mode between all lines and cabinet ground reference. |

| | |
|-------------|------------|
| Performance | Criteria B |
|-------------|------------|

Note: See the first note under Section 17.4 Immunity on page 214.

Fast Transient Test: AAU*Table 83 Fulfills the EEC type approval certification requirements according to:*

| | |
|------------------|--|
| Product standard | prETS 300 342-3, October 1997 |
| Basic standard | EN 61 000-4-4, 1995 |
| Test level | 0.5 kV common mode between all lines and cabinet ground reference. |
| Performance | Criteria TRptr |

Note: See the first note under Section 17.4 Immunity on page 214.

RF Common Mode: RBS*Table 84 Fulfills the EEC type approval certification requirements according to:*

| | |
|------------------|-------------------------------|
| Product standard | prETS 300 342-3, October 1997 |
| Basic standard | EN 61 000-4-6, 1996 |
| Frequency range | 150 kHz - 80 MHz |
| Test level | 3 V(rms) |
| Performance | Criteria CT Criteria CR |

Note: See the first note under Section 17.4 Immunity on page 214.

RF Common Mode: PBC

Note: See the first note under Section 17.4 Immunity on page 214.

RF Common Mode: AAU*Table 85 Fulfills the EEC type approval certification requirements according to:*

| | |
|------------------|-------------------------------|
| Product standard | prETS 300 342-3, October 1997 |
| Basic standard | EN 61 000-4-6, 1996 |
| Frequency range | 150 kHz - 80 MHz |
| Test level | 3 V(rms) |
| Performance | Criteria CRptr |

Note: See the first note under Section 17.4 Immunity on page 214.

Power Induction Test: RBS, PBC, AAU

Note: See the first note under Section 17.4 Immunity on page 214.

17.4.5 Immunity on Telecommunication Ports

Surge test

| | |
|---------------------|---------------|
| Basic standard | ITU-T K.21 |
| Pulse shape | 10/700 ms |
| Test no. | 1 a) and 1 b) |
| Test level | 4 kV |
| Acceptance criteria | A (K.21) |

Power induction test

| | |
|---------------------|---------------|
| Basic standard | ITU-T K.21 |
| Test no. | 2 a) and 2 b) |
| Test level | 600 V/1 s |
| Acceptance criteria | A (K.21) |

Power contact test

| | |
|---------------------|----------------------|
| Basic standard | ITU-T K.21 |
| Test no. | 3 a) and 3 b) |
| Test level | 230 V (50 Hz)/15 min |
| Acceptance criteria | B (K.21) |

17.4.6 Conducted Immunity For Direct Lightning Strike

RBS, PBC, AAU

Note: See the first note under Section 17.4 Immunity on page 214.

17.4.7 Radiated Immunity of Enclosure Port, Electric Fields

RBS

Table 86 Fulfills the EEC type approval certification requirements according to:

| | |
|------------------|-------------------------------|
| Product standard | prETS 300 342-3, October 1997 |
| Basic standard | EN 61 000-4-3, 1995 |
| Test level | 3 V/m |
| Frequency range | 80 MHz - 1 GHz |

| | |
|-------------|----------------------------|
| Performance | Criteria CT Criteria CR |
|-------------|----------------------------|

Note: See the first note under Section 17.4 Immunity on page 214.

PBC

Table 87 Fulfills the EEC self certification requirements according to:

| | |
|-----------------|--------------------------|
| Basic standard | IEC 801-3, 1984 |
| Test level | 3 V/m unmodulated signal |
| Frequency range | 27 MHz - 500 MHz |
| Performance | Criteria A |

Note: See the first note under Section 17.4 Immunity on page 214.

AAU

Table 88 Fulfills the EEC type approval certification requirements according to:

| | |
|------------------|-------------------------------|
| Product standard | prETS 300 342-3, October 1997 |
| Basic standard | EN 61 000-4-3, 1997 |
| Test level | 3 V/m |
| Frequency range | 80 MHz - 1 GHz |
| Performance | Criteria CRptr |

Note: See the first note under Section 17.4 Immunity on page 214.

17.4.8 Radiated Immunity of Enclosure Port, Magnetic Fields 50/60 Hz

RBS, PBC, AAU

Note: See the first note under Section 17.4 Immunity on page 214.

17.4.9 Electro-Static Discharges, Immunity of Enclosure Port

RBS

Table 89 Fulfills the EEC type approval certification requirements according to:

| | |
|------------------|--|
| Product standard | prETS 300 342-3, October 1997 |
| Basic standard | EN 61 000-4-2, 1995 |
| Test level | Contact discharge 4 kV Air discharge 8 kV |
| Performance | Criteria TT Criteria TR |

Note: See the first note under Section 17.4 Immunity on page 214.

PBC

Table 90 Fulfills the EEC self certification requirements according to:

| | |
|------------------|--------------------|
| Product standard | EN 50 082-1, 1992 |
| Basic standard | IEC 801-2, 1984 |
| Test level | Air discharge 8 kV |

| | |
|-------------|------------|
| Performance | Criteria B |
|-------------|------------|

Note: See the first note under Section 17.4 Immunity on page 214.

AAU

Table 91 Fulfills the EEC type approval certification requirements according to:

| | |
|------------------|-------------------------------|
| Product standard | prETS 300 342-3, October 1997 |
| Basic standard | EN 61 000-4-2, 1995 |
| Test level | Contact discharge 4 kV |

| | |
|-------------|----------------|
| Performance | Criteria TRptr |
|-------------|----------------|

Note: See the first note under Section 17.4 Immunity on page 214.

This page is intentionally left blank

18 EMC Capabilities for RBS 2401

This chapter covers the capabilities of the RBS 2401 in respect of EMC (ElectroMagnetic Compatibility). The capabilities include conducted and radiated emission as well as conducted and radiated immunity thresholds.

18.1 References and Concepts

For references and concepts, see chapter EMC Capabilities for RBS 2302.

18.2 Emission

18.2.1 Conducted Emission, Interference on AC Power Supply Ports

Table 92 Fulfills EEC type approval certification requirements according to:

| | |
|------------------|-------------------------------|
| Product standard | prETS 300 342-3, October 1997 |
| Basic standard | EN 55 022, 1994 |
| Limit | Class B |

18.2.2 Radiated Emission, Electric Field Emission

Table 93 Fulfills EEC type approval certification requirements according to:

| | |
|------------------|-------------------------------------|
| Product standard | prETS 300 342-3, October 1997 |
| Basic standard | I-ETS 300 609-1, 1997 |
| Frequency range | 30 MHz - 4 GHz |
| Operating mode | Transmitters with full output power |

18.3 Immunity

Note: Increased test level, extended frequency range and more severe performance criteria are specified by Ericsson internal EMC document.

18.3.1 Conducted Immunity on AC Power Ports

Fast Transient Test

Table 94 Fulfills the EEC type approval certification requirements according to:

| | |
|------------------|---|
| Product standard | prETS 300 342-3, October 1997 |
| Basic standard | EN 61 000-4-4, 1995 |
| Test level | 2 kV common mode between all lines and cabinet ground reference |
| | |
| Performance | Criteria TT Criteria TR |

Note: See the first note under Section 18.3 Immunity on page 225.

Surge Test*Table 95 Fulfills the EEC type approval certification requirements according to:*

| | |
|------------------|--|
| Product standard | prETS 300 342-3, October 1997 |
| Basic standard | EN 61 000-4-5, 1995 |
| Pulse shape | 1, 2/50 (8/20) us |
| Test level | 1 kV common mode between all lines and cabinet ground reference. 0.5 kV differential mode between line and line. |
| Performance | Criteria TT Criteria TR |

Note: See the first note under Section 18.3 Immunity on page 225.

RF Common Mode*Table 96 Fulfills the EEC type approval certification requirements according to:*

| | |
|------------------|-------------------------------|
| Product standard | prETS 300 342-3, October 1997 |
| Basic standard | EN 61 000-4-6, 1996 |
| Frequency range | 150 kHz - 80 MHz |
| Test level | 3 V(rms) |
| Performance | Criteria CT Criteria CR |

Note: See the first note under Section 18.3 Immunity on page 225.

Voltage Dips and Interruptions on AC Power Ports*Table 97 Fulfills the EEC type approval certification requirements according to:*

| | |
|------------------|---|
| Product standard | prETS 300 342-3, October 1997 |
| Basic standard | EN 61 000-4-11, 1994 |
| Test level 1 | Voltage dip, 30 % reduction of nominal voltage during 10 ms |
| Performance | Criteria TT Criteria TR Level 1 without battery back-up |

18.3.2 Conducted Immunity on Intra-Connecting Signal Ports

Fast Transient Test

Table 98 Fulfills the EEC type approval certification requirements according to:

| | |
|------------------|---|
| Product standard | prETS 300 342-3, October 1997 |
| Basic standard | EN 61 000-4-4, 1995 |
| Test level | 0.5 kV common mode between all lines and cabinet ground reference |
| | |
| Performance | Criteria TT Criteria TR |

Note: See the first note under Section 18.3 Immunity on page 225.

RF Common Mode

Table 99 Fulfills the EEC type approval certification requirements according to:

| | |
|------------------|-------------------------------|
| Product standard | prETS 300 342-3, October 1997 |
| Basic standard | EN 61 000-4-6, 1996 |
| Frequency range | 150 kHz - 80 MHz |
| Test level | 3 V(rms) |
| | |
| Performance | Criteria CT Criteria CR |

Note: See the first note under Section 18.3 Immunity on page 225.

18.3.3 Conducted Immunity on Telecommunication and External Signal Ports

Fast Transient Test

Table 100 Fulfills the EEC type approval certification requirements according to:

| | |
|------------------|---|
| Product standard | prETS 300 342-3, October 1997 |
| Basic standard | EN 61 000-4-4, 1995 |
| Test level | 0.5 kV common mode between all lines and cabinet ground reference |
| | |
| Performance | Criteria TT Criteria TR |

Note: See the first note under Section 18.3 Immunity on page 225.

RF Common Mode*Table 101 Fulfills the EEC type approval certification requirements according to:*

| | |
|------------------|-------------------------------|
| Product standard | prETS 300 342-3, October 1997 |
| Basic standard | EN 61 000-4-6, 1996 |
| Frequency range | 150 kHz - 80 MHz |
| Test level | 3 V(rms) |
| Performance | Criteria CT Criteria CR |

Note: See the first note under Section 18.3 Immunity on page 225.

18.3.4 Immunity on Telecommunication Ports**Surge test**

| | |
|---------------------|---------------|
| Basic standard | ITU-T K.21 |
| Pulse shape | 10/700 ms |
| Test no. | 1 a) and 1 b) |
| Test level | 4 kV |
| Acceptance criteria | A (K.21) |

Power induction test

| | |
|---------------------|---------------|
| Basic standard | ITU-T K.21 |
| Test no. | 2 a) and 2 b) |
| Test level | 600 V/1 s |
| Acceptance criteria | A (K.21) |

Power contact test

| | |
|---------------------|----------------------|
| Basic standard | ITU-T K.21 |
| Test no. | 3 a) and 3 b) |
| Test level | 230 V (50 Hz)/15 min |
| Acceptance criteria | B (K.21) |

18.3.5 Radiated Immunity of Enclosure Port, Electric Fields

Table 102 Fulfills the EEC type approval certification requirements according to:

| | |
|------------------|-------------------------------|
| Product standard | prETS 300 342-3, October 1997 |
| Basic standard | EN 61 000-4-3, 1995 |
| Test level | 3 V(rms) |
| Frequency range | 80 MHz - 1 GHz |
| | |
| Performance | Criteria CT Criteria CR |

Note: See the first note under Section 18.3 Immunity on page 225.

18.3.6 Electro-Static Discharges, Immunity of Enclosure Port

Table 103 Fulfills the EEC type approval certification requirements according to:

| | |
|------------------|--|
| Product standard | prETS 300 342-3, October 1997 |
| Basic standard | EN 61 000-4-2, 1995 |
| Test level | Contact discharge 4 kV Air discharge 8 kV |
| | |
| Performance | Criteria TT Criteria TR |

Note: See the first note under Section 18.3 Immunity on page 225.

This page is intentionally left blank

19 Broadcast

“Broadcast” denotes the RBS resources used for transmission of Synchronisation Information and System Information.

The RBS supports:

- Broadcast of Synchronisation Information on SCH and FCCH
- Broadcast of System Information 1, 2, 2bis, 2ter, 3 and 4 on BCCH
- Broadcast of System Information 5, 5bis, 5ter and 6 on SACCH
- Broadcast of System Information 7 and 8 on BCCH Extended

Short message service cell broadcast is covered within the context of Short Message Service.

19.1 References

| | |
|-------------|--|
| /GSM:04.06/ | GSM 04.06 (phase2) version 4.4.0 |
| /GSM:04.08/ | GSM 04.08 (phase2) version 4.10.1 and Amendment Request A015r5 |
| /GSM:05.02/ | GSM 05.02 (phase2) version 4.4.2 |
| /GSM:05.03/ | GSM 05.03 (phase2) version 4.2.0 |
| /GSM:05.10/ | GSM 05.10 (phase2) version 4.5.0 |
| /GSM:08.58/ | GSM 08.58 (phase2) version 4.7.0 and Amendment Request A006r1 |

Whenever a reference is made to a function described in another chapter, please refer to the table of contents to find the appropriate chapter.

19.2 Concepts

| | |
|---------------|--|
| BCCH Extended | Paging, Immediate Assign and System Information 7 and 8 may share the same TDMA frame mapping, see /GSM:05.02:6.5.1/ and /GSM:05.02:7: table 3 of 5/ |
|---------------|--|

19.3 Functions

19.3.1 Broadcast of Synchronisation Information

Synchronisation bursts are transmitted on SCH and Frequency Correction bursts are transmitted on FCCH.

The bursts are transmitted regularly, allowing attaching mobiles to synchronise on the TDMA structure and on the timing of the cell.

Supported logical channels /GSM:05.02:3.3.2/:

| | |
|------|------------------------------|
| FCCH | Frequency Correction Channel |
| SCH | Synchronisation Channel |

Supported channel combinations /GSM:05.02:6.4/:

- (iv) FCCH+SCH+BCCH+CCCH
- (v) FCCH+SCH+BCCH+CCCH+SDCCH/4(0..3)+SACCH/C4(0..3)

Transmission on FCCH is in accordance with /GSM:05.02:5.2.4./.

Transmission on SCH means transmission of BSIC (Base Station Identity Code) and RFN (Reduced Frame Number) in accordance with /GSM:05.02:5.2.5./, /GSM:05.03:4.7./ and /GSM:04.08:9.1.30./.

The BSIC value is received from the BSC, as a configuration parameter.

19.3.2 Reception of BCCH_INFORMATION from BSC

By means of the BROADCAST INFORMATION MODIFY procedure /GSM:08.58:5.5./, the BSC defines new System Information messages 1, 2, 2bis, 2ter, 3, 4, 7 and 8 to be stored and regularly broadcast by the RBS on the BCCH and BCCH Extended channel.

The RBS supports:

- Interpretation and check of the BCCH_INFORMATION message from BSC
- Storage and update of System Information 1-4 and 7-8

System Information is included in the BCCH_INFORMATION message received from the BSC. New System Information received is used in BCCH transmissions when scheduled.

Transmission of a specific System Information message can be stopped by a BCCH_INFORMATION message /GSM:08.58:8.5.1/ on order from the BSC.

19.3.3 Broadcast of System Information on BCCH

The RBS supports scheduled transmission of System Information on the BCCH channel /GSM:04.08:3.2.2.1/. Reception of System Information from the BSC is described in the section above.

Supported logical channels /GSM:05.02:3.3.2/:

BCCH Broadcast Control Channel

Supported channel combinations /GSM:05.02:6.4/:

- (iv) FCCH+SCH+BCCH+CCCH
- (v) FCCH+SCH+BCCH+CCCH+SDCCH/4(0..3)+SACCH/C4(0..3)

The following table defines the System Information type used depending on TC (Transaction Capabilities) /GSM:05.02:6.3.4/. If a type is not loaded from the BSC, the type within parenthesis is used (if it is loaded).

Table 104 Mapping of BCCH data

| TC | No 2bis, no 2ter | 2bis, no 2ter | No 2bis, 2ter | 2bis, 2ter |
|----|------------------|---------------|---------------|------------|
| 0 | 1 (3) | 1 (3) | 1 (3) | 1 (3) |
| 1 | 2 | 2 | 2 | 2 |

| | | | | |
|---|---------|---------|---------|---------|
| 2 | 3 | 3 | 3 | 3 |
| 3 | 4 and 8 | 4 and 8 | 4 and 8 | 4 and 8 |
| 4 | 3 | 3 | 3 | 2ter |
| 5 | 2 | 2bis | 2ter | 2bis |
| 6 | 3 | 3 | 3 | 3 |
| 7 | 4 and 7 | 4 and 7 | 4 and 7 | 4 and 7 |

Types 7 and 8 are sent on the BCCH Extended channel when they are loaded.

For BCCH blocks, where no System Information (1-4) is defined, "fill frames" /GSM:04.06:5.4.2.3/ are transmitted.

19.3.4 Reception of SACCH_FILLING from BSC

By means of the SACCH FILLING INFORMATION MODIFY procedure /GSM:08.58:6.2/, the BSC sends System Information 5, 5bis and 6 to be used on all SACCHs handled by a TRX (transceiver).

The RBS supports:

- Interpretation and check of the SACCH_FILLING message from BSC
- Storage and update of System Information 5, 5bis and 6

System Information is included in the SACCH_FILLING used for all SACCHs in one TRX. New System Information received is used in SACCH transmissions when scheduled.

Transmission of a specific System Information message can be stopped by a SACCH_FILLING message /GSM:08.58:8.5.1/ on order from the BSC.

19.3.5 Broadcast of System Information on SACCH

The RBS supports scheduled transmission of System Information on the SACCH channel /GSM:04.08:3.2.2.1/.

Reception of System Information from the BSC for all channel groups within a TRX is described in the section above. Reception of System Information for one particular channel group is described in chapter "Call Control", see table of contents.

Supported logical channels /GSM:05.02:3.3.4/:

SACCH Slow Associated Control Channel

Supported channel combinations /GSM:05.02:6.4/:

- (i) TCH/F + FACCH/F + SACCH/TF
- (ii) TCH/H(0,1) + FACCH/H(0,1) + SACCH/TH(0,1)
- (v) FCCH+SCH+BCCH+CCCH+SDCCH/4(0..3)+SACCH/C4(0..3)
- (vii) SDCCH/8(0..7) + SACCH/C8(0..7)

LAPDm frames /GSM:04.06:2.1 (format type B)/ are used for transmission of System Information on SACCH.

For SACCH blocks, where no System Information is defined, "fill frames" /GSM:04.06:5.4.2.3/ are transmitted.

TRS will change System Information message type for every transmission occasion according to Table 105 on page 234.

Even though the System Information types 5 and 6 are not optional, no checks are performed if they are stored (or deleted). If one of the System Information types 5 or 6 (or both) are missing the TRS shall change System Information message type for every transmission occasion according to Table 106 on page 234.

Table 105 SACCH System Information schedule

| <i>Stored System Information</i> | | | | <i>Transmission order</i> |
|----------------------------------|------|------|---|---------------------------|
| 5 | 5bis | 5ter | 6 | |
| * | * | * | * | 5, 5bis, 5ter, 6... |
| * | * | | * | 5, 5bis, 6... |
| * | | * | * | 5, 5ter, 6... |
| * | | | * | 5, 5, 6... |

Table 106 SACCH System Information schedule

| <i>Stored System Information</i> | | | | <i>Transmission order</i> |
|----------------------------------|------|------|---|---------------------------|
| 5 | 5bis | 5ter | 6 | |
| * | * | * | | 5, 5bis, 5ter... |
| | * | * | * | 5bis, 5ter, 6... |
| * | * | | | 5, 5bis... |
| * | | * | | 5, 5ter... |
| | * | * | | 5bis, 5ter... |
| | * | | * | 6, 5bis... |
| | | * | * | 6, 5ter... |
| * | | | | 5,5... |
| | * | | | 5bis, 5bis... |
| | | * | | 5ter, 5ter... |
| | | | * | 6, 6... |

For SACCH blocks, where no System Information is defined, "fill frames" /GSM:04.06:5.4.2.3/ are transmitted.

20 Common Control Channel Handling

"Common Control Channel Handling" denotes the RBS resources utilised for traffic on the Common Control channel.

20.1 References

| | |
|-------------|----------------------------------|
| /GSM:04.08/ | GSM 04.08 (phase2) version 4.5.0 |
| /GSM:08.58/ | GSM 08.58 (phase2) version 4.6.1 |
| /GSM:05.02/ | GSM 05.02 (phase2) version 4.3.0 |
| /GSM:05.03/ | GSM 05.03 (phase2) version 4.1.0 |

Whenever a reference is made to a function described in another chapter, please refer to the table of contents to find the appropriate chapter.

20.2 Function

20.2.1 Paging

By means of the PAGING procedure /GSM:08.58:5.2/, the RBS pages mobiles on command from the BSC. The RBS supports:

- Reception, interpretation and check of PAGING_COMMANDs from BSC
- Queuing of IMSI and TMSI
- Scheduled transmission of PAGING_REQUEST messages on PCH
- Retransmission of PAGING_REQUEST messages on PCH

Channel combinations /GSM:05.02:6.4/ supported:

- (iv) FCCH+SCH+BCCH+CCCH
- (v) FCCH+SCH+BCCH+CCCH+SDCCH/4(0..3)+SACCH/C4(0..3)

PAGING_COMMAND messages from BSC with the following MS IDENTITY (Id-type) are supported:

IMSI International Mobile Subscriber Identity

TMSI Temporary Mobile Subscriber Identity

IMSI and TMSI are queued for scheduled transmission on PCH. One paging queue is supported for each paging group.

The following messages are used for scheduled transmission of IMSI and TMSI is made with:

- PAGING_REQUEST_TYPE_1 /GSM:04.08:9.1.22/
- PAGING_REQUEST_TYPE_2 /GSM:04.08:9.1.23/
- PAGING_REQUEST_TYPE_3 /GSM:04.08:9.1.24/

For dequeuing, priority handling, selection of Page mode, transmission and retransmission, see para. 11.2.3.

20.2.2 Immediate Assign

By means of the IMMEDIATE ASSIGNMENT procedure / GSM:08.58:5.7./, the network signals acceptance or rejection of a CHANNEL_REQUEST message from MS.

The RBS supports:

- Reception, interpretation and check of IMMEDIATE_ASSIGN_COMMAND messages from BSC
- Queuing of IA (Immediate Assign) and IAR (Immediate Assign Reject)
- Scheduled transmission of IMMEDIATE_ASSIGNMENT messages on AGCH (Access Grant CHannel)
- Retransmission of IMMEDIATE_ASSIGNMENT messages on AGCH

IAs and IARs are queued for scheduled transmission on the AGCH. The RBS supports one queue for IA messages and one for IAR messages. The following messages are used for scheduled transmission of IA and IAR:

- IMMEDIATE_ASSIGNMENT /GSM:04.08:9.1.18/
- IMMEDIATE_ASSIGNMENT_EXTENDED /GSM:04.08:9.1.19/
- IMMEDIATE_ASSIGNMENT_REJECT /GSM:04.08:9.1.20/

For dequeuing, priority handling, selection of Page Mode, transmission and retransmission, see para. 11.2.3.

20.2.3 CCCH Dequeuing and Transmission

Downlink CCCH capacity is used for PAGING as well as for access grant (IMMEDIATE ASSIGN).

The RBS supports:

- Dequeuing and scheduling
- Packing of messages
- Selection of Page Mode
- Retransmission of messages
- Dummy paging

Handling of Paging is covered in the section Paging above. Handling of Immediate Assign is covered in the section Immediate Assign above.

Supported Logical Channels /GSM:05.02:3.3.3/:

| | |
|------|----------------------|
| AGCH | Access Grant Channel |
| PCH | Paging Channel |

Dequeuing and Scheduling

The RBS dequeues and transmits messages from the CCCH queue system in the following order of priority, where a) has the highest priority:

- a) IMMEDIATE_ASSIGNMENT
 - /GSM:04.08:9.1.18/
 - /GSM:04.08:9.1.19/
- b) IMMEDIATE_ASSIGNMENT_REJECT
 - /GSM:04.08:9.1.20/
- c) PAGING_REQUEST (Normal Paging)
 - /GSM:04.08:9.1.22/
 - /GSM:04.08:9.1.23/
 - /GSM:04.08:9.1.24/
- d) PAGING_REQUEST (Extended Paging)

If no messages are queued for transmission:

- IMSIs, TMSIs and IAs stored for retransmission (see the section Retransmission of messages below) are sent at the same priority level as described above
- If no messages are stored for retransmission, "Dummy Paging" is used (see the section Dummy Paging below)

IMMEDIATE_ASSIGNMENT messages:

The queues are handled in a FIFO (First-In-First-Out) manner when the following messages are composed:

- IMMEDIATE_ASSIGNMENT
- IMMEDIATE_ASSIGNMENT_EXTENDED (first IA)
- IMMEDIATE_ASSIGNMENT_REJECT (first IAR)

PAGING_REQUEST messages:

The queues are handled in a FIFO manner when the first IMSI or TMSI intended for a PAGING REQUEST message is dequeued.

Packing of Messages

IMMEDIATE_ASSIGNMENT messages:

If possible, two IAs (queued or stored for retransmission) will be packed into one IMMEDIATE_ASSIGNMENT_EXTENDED message.

A maximum of four unique IARs can be packed into one IMMEDIATE_ASSIGNMENT_REJECT message.

PAGING_REQUEST messages:

As many IMSIs and TMSIs as possible (for a certain paging group) will be packed into one PAGING_REQUEST message (type 1, 2 or 3). If Extended paging is used (see the section Selection of Page Mode below), IMSIs and TMSIs originating from two different paging groups may be packed into the same PAGING_REQUEST message.

IMSIs and TMSIs stored for retransmission (in the corresponding paging stack) are included in the PAGING_REQUEST message if not enough IMSIs or TMSIs are found in the actual paging queue.

Selection of Page Mode

The RBS selects the appropriate Page mode value /GSM:04.08:-10.5.2.26./ for each message. The following Page modes are used:

- Normal
- Extended
- Paging reorganization

The allowed use of extended page mode is configured (as a percentage) on command from the BSC. This is done by means of configuration parameter DRX_DEV_MAX, see the section Administration below.

Page mode extended makes it possible for the RBS to transit IMSI:s or TMSI:s for a certain paging group when the next but one paging group is scheduled /GSM:04.08:3.3.2.1/.

The “Page Mode” element (of the PAGING_REQUEST or IMMEDIATE_ASSIGNMENTs messages), set to extended Paging, is sent as an indication to the MS to be prepared to handle extended Paging as described above. The allowed use of extended page mode is defined (in percentage) by means of configuration parameter DRX_DEV_MAX, see MAX, see the section Administration below.

On receipt of an IMMEDIATE_ASSIGN_COMMAND* with page mode set to Paging reorganization, RBS uses Page Mode “Paging reorganization” in all of the following air interface messages:- IMMEDIATE ASSIGNMENT-IMMEDIATE ASSIGNMENT REJECTED-IMMEDIATE ASSIGNMENT EXTENDED-PAGING REQUEST 1–3, including dummy paging

TRS uses Page Mode “Paging reorganization” until an IMMEDIATE ASSIGNMENT COMMAND* message is received with page mode set to normal paging or extended paging. The TRS then swaps page mode from “Paging reorganization” to normal operation, which means that normal paging or extended paging is used.

If an IMMEDIATE_ASSIGN_COMMAND* is received with page mode set to 'Same as before' the page mode is not changed.

Note: It should be made clear that it is the L3 immediate assign message carried within the IMMEDIATE_ASSIGN_COMMAND that contains the page mode parameter.

Retransmission of Messages

Copies of IMSIs, TMSIs and IAs transmitted from their respective queues, are stored on a stack (one stack/ paging queue) for retransmission (IARs are not stored for retransmission).

An IMSI or TMSI stored for retransmission is discarded, depending on the setting of parameter BS_PA_MFRMS (see section Administration below) as specified below:

- BS_PA_MFRMS _ 3
 - The IMSI/TMSI is discarded if it has not been retransmitted within two schedulings of its paging group

- BS_PA_MFRMS > 3
 - The IMSI/TMSI is discarded if it has not been retransmitted within one scheduling of its paging group

No message is retransmitted more than once. An IA is discarded if it has not been retransmitted within 80 ms. The BSC may turn the retransmission function on and off by means of configuration parameter CCCH Repeat, see the section Administration below.

Dummy Paging

Whenever no PAGING_REQUEST or IMMEDIATE_ASSIGNMENT message is scheduled for transmission in a CCCH block, a Dummy Paging message is used.

The message used for Dummy Paging is a PAGING_REQUEST type 1 /GSM:04.08:9.1.22./.

Administration

The following configuration parameters are used to control the transmission of PAGING_REQUEST messages and IMMEDIATE_ASSIGNMENT messages on downlink CCCH:

Table 107 Configuration parameters

| Parameter | Supported values | Description |
|---------------|------------------|---|
| BS_AG_BLK_RES | 0-1 | Number of blocks in each 51 TDMA frame multiframe reserved for AGCH / GSM:05.02:3.3.2.3/ /GSM:05.02:6.5.1/. |
| BS_PA_MFRMS | 2-9 | Number of 51 TDMA frame multiframe between transmissions of paging messages to mobiles of the same paging group /GSM:05.02:3.3.2.3/ / GSM:05.02:6.5.1/. |
| CCCH repeat | ON, OFF | Automatic retransmission of pagings and immediate assigns in use (ON), or not in use (OFF). |
| DRX_DEV_MAX | 0-100 | 0-100% allowed use of extended page mode per paging group (for example 50%, means that Page mode Extended is used every other time it is possible to use it). |

20.2.4 Channel Request by MS

By means of the CHANNEL REQUEST BY MS procedure / GSM:08.58:5.1./, the RBS detects channel requests (random accesses) from MSs, and reports these as CHANNEL_REQUIRED messages to BSC.

The RBS supports:

- Detection of CHANNEL_REQUESTS on RACH
- Transmission of CHANNEL_REQUIRED messages to BSC

The channel request is coded as AB (access bursts) /GSM:05.02:5.2.7./ and /GSM:05.03:4.6./.

The RBS observes the TDMA frame number and measures the access delay of the AB arrival.

If the rate of CHANNEL_REQUESTs is higher than specified in the section Operational Conditions below, messages may be temporarily stored before transmission to the BSC. Messages not transmitted within 50 ms are discarded. Stored messages are transferred in the same order as they arrive from MS.

Emergency calls have precedence over temporarily stored messages.

Each accepted CHANNEL_REQUEST is reported to BSC as a CHANNEL_REQUIRED message according to /GSM:08.58:8.5.3/.

20.3 Operational Conditions

20.3.1 Paging

The number of paging groups supported by the RBS is dependent on the channel combination:

- (iv) The use of 16-81 paging groups is supported
- (v) The use of 4-27 paging groups is supported

The paging queue length varies between 6 and 14 depending on the number of paging queues in use. The length is calculated as:

Length = $14 - (PQMax/10)$; where PQMax = the highest paging group/queue in use.

20.3.2 Immediate Assign

Max. number of elements in the IA queue = 10 and in the IAR queue = 10.

20.3.3 CCCH Dequeuing and Transmission

A number of stacks are used for message retransmission:

- One IA stack, number of elements = 4
- Paging stacks (one stack/paging queue), number of elements/stack = 4

20.3.4 Channel Request by MS

The RBS can receive and perform acceptance checks, corresponding to full RACH capacity. The RBS can report accepted channel requests, as CHANNEL_REQUIRED messages, corresponding to 37% of the requests on full RACH load.

21 Physical Channel Handling

"Physical Channel Handling" covers the traffic services provided by the physical layer in the RBS for the air interface.

21.1 References

/GSM:05.02/ GSM 05.02 (phase 2) version 4.3.0

/GSM:05.03/ GSM 05.03 (phase 2) version 4.1.0

Whenever a reference is made to a function described in another chapter, please refer to the table of contents to find the appropriate chapter.

21.2 Functions

21.2.1 Supported Burst Types

The following burst types are supported /GSM:05.02:5.2/:

- Normal burst
- Frequency correction burst
- Synchronisation burst
- Dummy burst
- Access burst

21.2.2 Supported Logical Channels

The following logical channels are supported /GSM:05.02:3/:

| | |
|----------|---|
| BCCH | Broadcast Control Channel |
| CBCH | Cell Broadcast Channel |
| CCCH | Common Control Channel, comprising: <ul style="list-style-type: none"> – AGCH Access Grant Channel – PCH Paging Channel – RACH Random Access Channel |
| FACCH/F | Fast Associated Control Channel, full rate |
| FACCH/H | Fast Associated Control Channel, half rate |
| FCCH | Frequency Correction Channel |
| SACCH/C4 | Slow Associated Control Channel, dedicated control/4 |
| SACCH/C8 | Slow Associated Control Channel, dedicated control/8 |
| SACCH/TF | Slow Associated Control Channel, full rate traffic |

| | |
|----------|--|
| SACCH/TH | Slow Associated Control Channel, half rate traffic |
| SCH | Synchronization Channel |
| SDCCH/4 | Stand-Alone Dedicated Control Channel/4 |
| SDCCH/8 | Stand-Alone Dedicated Control Channel/8 |
| TCH/F | Traffic Channel, full rate |
| TCH/H | Traffic Channel, half rate |
| TCH/FD | Traffic Channel, full rate, uni-directional, multislot configuration. |
| SACCH/M | Slow Associated Control Channel, full rate traffic, multislot configuration. |
| SACCH/MD | SACCH/MD is defined as the downlink part of SACCH/M |

21.2.3 Supported Channel Combinations

The following channel combinations are supported /GSM:05.02:3/:

- (i) TCH/F + FACCH/F + SACCH/TF
- (ii) TCH/H(0,1) + FACCH/H(0,1) + SACCH/TH(0,1)
- (iv) FCCH + SCH + BCCH norm. + BCCH ext. + CCCH
- (v)
 - a) FCCH + SCH + BCCH norm. + BCCH ext. + CCCH + SDCCH/4[0..3] + SACCH/C4[0..3]
 - b) FCCH + SCH + BCCH + CCCH + SDCCH/4[0,1,3] + SACCH/C4[0,1,3] + CBCH
- (vi) BCCH + CCCH (only hardware supported)
- (vii)
 - a) SDCCH/8[0..7] + SACCH/C8[0..7]
 - b) SDCCH/8[0,1,3..7] + SACCH/C8[0,1,3..7] + CBCH
- (viii) TCH/F + FACCH/F + SACCH/M
- (ix) TCH/F + SACCH/M
- (x) TCH/FD + SACCH/MD

Note: CCCH = PCH + RACH + AGCH.

Note: Channel Combinations (v) and (vii) type b, are valid only when SMS Cell Broadcast is configured. In case of Channel Combination (vii), CBCH is only allowed for TN (Timeslot Number)=0..3.

Note: Channel Combinations (iv) and (v) must be configured for TN=0.

Note: Channel Combinations (vi) can only be configured for TN=2, 4, 6.

21.2.4 Channel Coding

Channel Coding (downlink) is performed according to:

/GSM:05.03:3/ Traffic Channels

/GSM:05.03:4/ Control Channels

21.2.5 Channel Decoding

Channel Decoding (uplink) is performed according to:

/GSM:05.03:3/ Traffic Channels

/GSM:05.03:4/ Control Channels

21.2.6 Interleaving

Interleaving (downlink) is performed according to:

/GSM:05.03:3/ Traffic Channels

/GSM:05.03:4/ Control Channels

21.2.7 De-interleaving

De-interleaving (uplink) is performed according to:

/GSM:05.03:3/ Traffic Channels

/GSM:05.03:4/ Control channels

21.2.8 Burst Assembly

Burst Assembly is performed according to:

/GSM:05.02:5.2.3/ Normal bursts

/GSM:05.02:5.2.4/ Frequency correction bursts

/GSM:05.02:5.2.5/ Synchronisation bursts

/GSM:05.02:5.2.6/ Dummy bursts

/GSM:05.02:5.2.7/ Access bursts

21.2.9 Multiplexing

Multiplexing of bursts into TDMA frames is performed according to:

/GSM:05.02:7 Table 1/

/GSM:05.02:7 Table 2/

/GSM:05.02:7 Table 3/

/GSM:05.02:7 Table 4/

/GSM:05.02:7 Table 5/

22 Speech and Data Services

This chapter covers speech and data services, as well as the handling of the link between the RBS and the RTC (Remote TransCoder) when neither speech nor data is present.

22.1 References

| | |
|-------------|------------------------------|
| /GSM:03.05/ | GSM 03.05 Phase 2 Ver 4.0.0 |
| /GSM:08.20/ | GSM 08.20 Phase 2 Ver 4.1.0 |
| /GSM:08.54/ | GSM 08.54 Phase 2 Ver 4.0.0 |
| /GSM:08.58/ | GSM 08.58 Phase 2 Ver 4.2.0 |
| /GSM:08.60/ | GSM 08.60 Phase 2 Ver 4.1.0 |
| /GSM:08.61/ | GSM 08.61 Phase 2 Ver 4.1.0 |
| /GSM:11.20/ | GSM 11.20 Phase 1 Ver 3.11.0 |

Whenever a reference is made to a function described in another chapter, please refer to the table of contents to find the appropriate chapter.

22.2 Concepts

| | |
|-----------------------------|--|
| Air Timeslot Resource | The functional entity responsible for all Air interface functions for one Air timeslot. The Air timeslot resource can be seen as 1/8 of a TRX. |
| Terrestrial Traffic Channel | Physical channel used for communication with remote transcoder/rate adapter. |
| RTC | When the transcoders/rate adapters are positioned remote from the RBS, they are called RTCs. In this document, the RTC is a part of BSC but is controlled by the RBS. |
| TRAU Frame | To control the RTC from the RBS, control information is added to the coded speech information (or data information). This results in a data block called a TRAU (Transcoder Rate Adapter Unit) frame which is transferred between the RBS and RTC as described in /GSM:08.60/. The size of the TRAU frame for full rate speech/data/idle speech is 320 bits. |

22.3 Functions

22.3.1 Idle Transmission over A-bis

Idle transmission over A-bis is initiated:

- When the Managed Object (MO) corresponding to an air timeslot resource receives a start order via A-bis Operation and Maintenance Link (OML)
- When a TCH ceases to exist because of a disable order to the MO corresponding to an air timeslot resource, via A-bis OML

Idle transmission over A-bis is active for the following channels and conditions:

- Common Resource channels, idle transmission always active
- SDCCH channels, idle transmission always active
- TCH channels, idle transmission active when there is no channel.

A 16 kbit/s idle pattern, as specified in /GSM:08.54/, is continuously sent to the RTC on the terrestrial traffic channel allocated to the air timeslot resource.

Idle transmission over A-bis is terminated when a traffic channel is enabled on the air timeslot resource.

22.3.2 Terrestrial Link Supervision

The function Terrestrial Link Supervision (TLS) supervises a terrestrial link (16 kbps) for a traffic channel and decides when a connection is considered lost.

The TLS function is set to On or Off for an idle or active subchannel.

TLS on idle subchannel is set On:

- 16 kbps resource in IDLE state:
Idle speech is transmitted
Terrestrial link supervision is active.
- 8 kbps resource in IDLE state (this case only exists when the other 8 kbps resource is in ACTIVE state):
Idle pattern is transmitted
Terrestrial link supervision *isnot* active.

TLS on idle subchannel is set Off:

For all these cases terrestrial link supervision is not active.

- 16 kbps resource in IDLE state:
Idle pattern is transmitted.
- 8 kbps resource in IDLE state (this case only exists when the other 8 kbps resource is in ACTIVE state)

Idle pattern is transmitted

When both 8 kbps subchannels of a common TS resource go into idle state they are transformed into one 16 kbps idle resource.

Idle pattern is generated as specified in /GSM:08.54/.

TLS on active subchannel is set On:

- TCH in ACTIVE state including all sub-states and the channel mode is *not* “signalling”.

Terrestrial link used for traffic.

Terrestrial link supervision is active.

- TCH in ACTIVE state including all sub-states and the channel mode is “signalling”.

Idle pattern is transmitted.

Terrestrial link supervision is *not* active.

TLS on active subchannel is set Off:

For all these cases terrestrial link supervision is not active.

- TCH in ACTIVE state including all sub-states and the channel mode is *not* “signalling”.

Terrestrial link used for traffic.

- TCH in ACTIVE state including all sub-states and the channel mode is “signalling”.

Idle pattern is transmitted.

Idle pattern is generated as specified in /GSM:08.54/.

This function supervises the downlink TRAU frames. The synchronization bits have to be correct and the received frame type must be expected.

The synchronization pattern for an idle subchannel is generated either in the TRA or the BTS (loop). The BTS accepts either one of the synchronization patterns.

If disturbances on the link result in a long duration of synchronization and/or frame type errors which exceeds the TLS Filtering Time (a configured value) then an error condition is considered present.

When an error condition is present and supervision is On this is reported to BSC via a FAULT_REPORT message.

If the channel is in ACTIVE state and TLS on active subchannel is On then a CONNECTION_FAILURE_INDICATION message is sent to the BSC.

22.3.3 Full Rate Speech

Full Rate Speech is either initiated by the Channel Activation function or the Mode Modify function.

In order to activate coding/decoding of speech in the RTC, the RBS issues TRAU frames of type Speech/Enhanced speech.

In order to deactivate speech coding/decoding in the RTC, the RBS issues TRAU frames of type Idle Speech.

During the exchange of TRAU frames between RBS and RTC carrying Full Rate Speech (or Full Rate Idle Speech), the RBS regularly calculates an appropriate time alignment value for controlling the downlink frame timing. This value is included in the transmitted TRAU frames.

The TRAU frames exchanged between BTS and RTC during an active call are of three types:

- Speech
- Enhanced Speech
- Idle Speech (used by DTX function GSM speech algorithm version 1 only)
- Speech containing coded silence information

TRAU frame type Speech uses GSM speech algorithm version 1 and frame type Enhanced Speech uses GSM speech algorithm version 2 as coding/decoding of full rate speech.

For TRAU frames of type Speech, improvements of the subjective speech quality is described under: Subjective Speech Quality Improvements.

Full rate speech is either terminated by the RF Channel Release function, or the Mode Modify function when Data or Signalling services are requested.

Subjective Speech Quality Improvements

The RBS supports subjective speech quality improvements that go beyond what is required in the GSM recommendations. The objective is to avoid unpleasant noise effects that would result from e.g. normal decoding of lost speech frames.

To improve the subjective speech quality uplink in cases of bad frames reception, the RBS takes local measures such as "substitution" and "muting" of frames and computes an improved BFI (Bad Frame Indicator). This calculation takes advantage of quality information from the channel decoder.

To improve speech quality downlink, filtering of TRAU frames is done after detection of disturbances in the frame quality. The filtering is removed when the disturbances have disappeared.

22.3.4 Half Rate Speech

Half Rate Speech is either initiated by the Channel Activation function or the Mode Modify function.

In order to activate coding/decoding of speech in the RTC, the RBS issues TRAU frames of type Speech.

In order to deactivate speech coding/decoding in the RTC, the RBS issues TRAU frames of type Idle Pattern according to /GSM:08.61/.

During the exchange of TRAU frames between RBS and RTC carrying half rate speech, the RBS regularly calculates an appropriate time alignment value for controlling the downlink frame timing. This value is included in the transmitted TRAU frames.

The TRAU frames exchanged between RBS and RTC during an active call are of the following types:

- Speech
- Speech containing coded silence information (used by function DTX).

Half Rate Speech is either terminated by the RF Channel Release function, or the Mode Modify function when Data or Signalling services are requested.

22.3.5 Full Rate Data

Full rate data is either initiated by the Channel Activation function or the Mode Modify function.

In order to activate and control rate adaptation of data in the RTC, the RBS issues TRAU frames of type Data and channel type Full Rate.

In order to deactivate rate adaptation of data in the RTC, the RBS issues TRAU frames of type Idle Speech and channel type Full Rate, according to /GSM:08.60/.

The rate adaptation is split up between RTC and RBS and is performed as described in /GSM:08.20/ and /GSM:08.60/.

The TRAU frames exchanged between RBS and RTC during an active call can be of the following types:

- Data
- Data, containing Idle Data

The arrival of data blocks from the air interface is supervised by the RBS.

If no data block is received, it is replaced by an idle data block.

Full Rate Data is either terminated by the RF Channel Release function, or the Mode Modify function when Speech or Signalling services are requested.

22.3.6 Half Rate Data

Full Rate Data is either initiated by the Channel Activation function or the Mode Modify function.

In order to activate and control rate adaptation of data in the RTC, the RBS issues TRAU frames of type Data.

In order to deactivate rate adaptation of data in the RTC, the RBS issues TRAU frames of type Idle Speech according to /GSM:08.61/.

The rate adaptation is split up between RTC and RBS and is performed as described in /GSM:08.20/ and /GSM:08.61/.

The TRAU frames exchanged between RBS and RTC during an active call can be of the following types:

- Data
- Data, containing Idle Data

The arrival of data blocks from the air interface is supervised by the RBS.

If no data block is received, it is replaced by an idle data block.

Half Rate Data is either terminated by the RF Channel Release function, or the Mode Modify function when Speech or Signalling services are requested.

22.4 Operational Conditions

22.4.1 Full Rate Speech

The round-trip delay for a full rate speech channel, introduced by the BTS, is less than 68 ms.

The values are including additional delay due to the measuring method as described in /GSM 11.20:7.2.6, table 7–2b/.

22.4.2 Full Rate Data

Transparent data services supported:

- 9.6 kbits/s
- 4.8 kbits/s
- 2.4 kbits/s
- 1.2 kbits/s
- 1200/75 bits/s
- 600 bits/s

Non-transparent data services supported:

- 9.6 kbits/s

The round-trip delay for a full rate data channel, introduced by the RBS is:

- Less than 89 ms for TCH/F2.4 (this includes TCH/F1.2, TCH/F1.2/75 and TCH/F0.6 as well)
- Less than 160 ms for TCH/F4.8, TCH/F9.6
- Less than 175 ms for TCH/F9.6NT

The values are including additional delay due to the measuring method as described in /GSM 11.20:7.2.6, table 7–2b/.

22.4.3 Half Rate Speech

The round-trip delay for a half rate speech channel, introduced by the BTS, is less than 63 ms.

The values are including additional delay due to the measuring method as described in /GSM 11.20:7.2.6, table 7-2b/.

22.4.4 Half Rate Data

Transparent data services supported:

- 4.8 kbits/s
- 2.4 kbits/s
- 1.2 kbits/s
- 1200/75 bits/s
- 600 bits/s

Non-transparent data services supported:

- 4.8 kbits/s

The round-trip delay for a half rate data channel, introduced by the BTS is:

- Less than 284 ms for TCH/H4.8 and TCH/H2.4(this includes TCH/H1.2, TCH/H1.2/75 and TCH/H0.6 as well)
- Less than 315 ms for TCH/H4.8NT.

The values are including additional delay due to the measuring method as described in /GSM 11.20:7.2.6, table 7-2b/.

This page is intentionally left blank

23 Call Control

The Call Control function defines the RBS functions related to call establishment and call control on the air interface.

23.1 References

| | |
|-------------|-------------------------------------|
| /GSM 04.04/ | GSM 04.04 (phase 2) version: 4.0.4 |
| /GSM 04.06/ | GSM 04.06 (phase 2) version: 4.4.0 |
| /GSM 04.08/ | GSM 04.08 (phase 2) version: 4.10.1 |
| /GSM 05.02/ | GSM 05.02 (phase 2) version: 4.4.2 |
| /GSM 05.05/ | GSM 05.05 (phase 2) version: 4.10.0 |
| /GSM 05.10/ | GSM 05.10 (phase 2) version: 4.5.0 |
| /GSM 08.58/ | GSM 08.58 (phase 2) version: 4.7.0 |

Whenever a reference is made to a function described in another chapter, please refer to the table of contents to find the appropriate chapter.

23.2 Channel Activation

Purpose

To prepare a dedicated channel for use and start up reception and transmission on associated channels. /GSM 08.58:4.1/

Preconditions and initiation

Supported channel combinations /GSM 05.02:6.4/

- (i) TCH/F + FACCH/F + SACCH/TF
- (ii) TCH/H(0,1) + FACCH/H(0,1) + SACCH/TH(0,1)
- (v) FCCH + SCH + BCCH + CCCH+ SDCCH/4[0..3] + SACCH/C4[0..3]
- (vii) SDCCH/8[0..7] + SACCH/C8[0..7]
- (viii) TCH/F + FACCH/F + SACCH/M
- (ix) TCH/F + SACCH/M
- (x) TCH/FD + SACCH/MD

Supported channel numbers /GSM 08.58:9.3.1/

- Bm + ACCHs (Associated Control Channels)
- Lm + ACCHs
- SDCCH/8 + ACCH
- SDCCH/4 + ACCH

Supported activation types /GSM 08.58:9.3.3/

- Immediate Assign
- Normal Assign
- Asynchronous Handover

Supported channel modes /GSM 08.58:9.3.6/

| | |
|--------|---|
| TCH/F | Signalling |
| TCH/H | Signalling |
| TCH/FS | Full rate speech, GSM speech alg. Ver 1 |
| TCH/FS | Full rate speech, GSM speech alg. Ver 2 |
| TCH/HS | Half rate speech |
| SDCCH | Signalling |

For the non-transparent service

| | |
|----------|---|
| TCH/F9.6 | Full rate data 9.6 kbit/s non-transparent |
| TCH/H4.8 | Half rate data 4.8 kbit/s non-transparent |

For the transparent service

| | |
|----------|---|
| TCH/F9.6 | Full rate data 9.6 kbit/s transparent |
| TCH/F4.8 | Full rate data 4.8 kbit/s transparent |
| TCH/F2.4 | Full rate data 2.4 kbit/s transparent |
| TCH/F2.4 | Full rate data 1.2 kbit/s transparent |
| TCH/F2.4 | Full rate data 600 bit/s transparent |
| TCH/F2.4 | Full rate data 1200/75 bit/s (1200 network >MS, 75 MS >network) transparent |
| TCH/F | Signalling, Bi-directional (not allowed on channel combination ix) |
| TCH/FS | Full rate speech, GSM speech alg. Ver 1, Bi-directional |
| TCH/FS | Full rate speech, GSM speech alg. Ver 2, Bi-directional |
| TCH/F9.6 | Full rate data 9.6 kbit/s non-transparent, Bi-directional |
| TCH/H4.8 | Half rate data 4.8 kbit/s non-transparent, Bi-directional |
| TCH/F9.6 | Full rate data 9.6 kbit/s transparent, Bi-directional |

| | |
|----------|---|
| TCH/F4.8 | Full rate data 4.8 kbit/s transparent, Bi-directional |
| TCH/F2.4 | Full rate data 2.4 kbit/s transparent, Bi-directional |
| TCH/F2.4 | Full rate data 1.2 kbit/s transparent, Bi-directional |
| TCH/F2.4 | Full rate data 600 bit/s transparent, Bi-directional |
| TCH/F2.4 | Full rate data 1200/75 bit/s transparent, Bi-directional |
| TCH/FS | Full rate speech, GSM speech alg. Ver 1, Uni-directional |
| TCH/FS | Full rate speech, GSM speech alg. Ver 2, Uni-directional |
| TCH/F9.6 | Full rate data 9.6 kbit/s non-transparent, Uni-directional |
| TCH/H4.8 | Half rate data 4.8 kbit/s non-transparent, Uni-directional |
| TCH/F9.6 | Full rate data 9.6 kbit/s transparent, Uni-directional |
| TCH/F4.8 | Full rate data 4.8 kbit/s transparent, Uni-directional |
| TCH/F2.4 | Full rate data 2.4 kbit/s transparent, Uni-directional |
| TCH/F2.4 | Full rate data 1.2 kbit/s transparent, Uni-directional |
| TCH/F2.4 | Full rate data 600 bit/s transparent, Uni-directional |
| TCH/F2.4 | Full rate data 1200/75 bit/s transparent, Uni-directional |
| TCH/H4.8 | Half rate data 4.8 kbit/s non-transparent |
| TCH/H4.8 | Half rate data 4.8 kbit/s transparent |
| TCH/H2.4 | Half rate data 2.4 kbit/s transparent |
| TCH/H2.4 | Half rate data 1.2 kbit/s transparent |
| TCH/H2.4 | Half rate data 600 bit/s transparent |

TCH/H2.4 Half rate data 1200/75 bit/s (1200 network >MS, 75 MS >networ) transparent

Note: TCH/F4.8 non-transparent is only hardware supported.

Classification (see section Concepts) of elements, common for all activation types

| | |
|------------------------|----------|
| Channel Identification | Ignored |
| BS Power | Optional |
| MS Power | Required |
| BS Power Parameters | Rejected |
| MS Power Parameters | Rejected |
| Physical Context | Rejected |

Immediate Assign /GSM 08.58:4.1/

The optional elements for Immediate Assign are:

| | |
|------------------------|----------|
| Encryption Information | Rejected |
| Handover Reference | Rejected |
| Timing Advance | Required |

Normal Assignment /GSM 08.58:4.1/

The optional elements for Normal Assignment are:

| | |
|------------------------|----------|
| Encryption Information | Optional |
| Handover Reference | Rejected |
| Timing Advance | Required |
| SACCH Information | Optional |

If the parameter SACCH Information is present, the contents will be used for this channel group instead of the information received in the SACCH FILLING INFORMATION MODIFY procedure described in Broadcast.

Asynchronous Handover /GSM 08.58:4.1/

The optional elements for Asynchronous Handover are:

| | |
|------------------------|----------|
| Encryption Information | Optional |
| Handover Reference | Required |
| Timing Advance | Rejected |
| SACCH Information | Optional |

If the parameter SACCH Information is present, the contents will be used for this channel group instead of the information received by the SACCH FILLING INFORMATION MODIFY procedure described in Broadcast.

Multislot configuration (secondary channels) /GSM 08.58:4.1/

The activation for the multislot configuration procedure is in accordance with /GSM 08.58:4.1/.

Encryption Information Optional

Handover Reference Rejected

Timing Advance Rejected

SACCH Information Optional

If the parameter SACCH Information is present, the contents will be used for this channel group instead of the information received in the SACCH FILLING INFORMATION MODIFY procedure described in Broadcast.

The function is initiated when a CHANNEL_ACTIVATION / GSM 08.58:4.1/ message is received from BSC.

Description

In order to activate a channel between MS and RBS, the RBS receives an idle traffic channel from BSC in a Channel_Activation message. This message contains the reason for the activation (immediate assignment, normal assignment, asynchronous handover, multislot configuration), the identification of the channel to be used (channel no.) and a complete description of the channel (full/half rate, speech/data, coding/rate adaption, hopping sequence, encryption key, and so forth).

If the activation of the channel is successful, the RBS answer is Channel_Activation_Acknowledgement. Otherwise, if the channel for some reason cannot activate, the answer is a Channel_Activation_Negative_Acknowledgement.

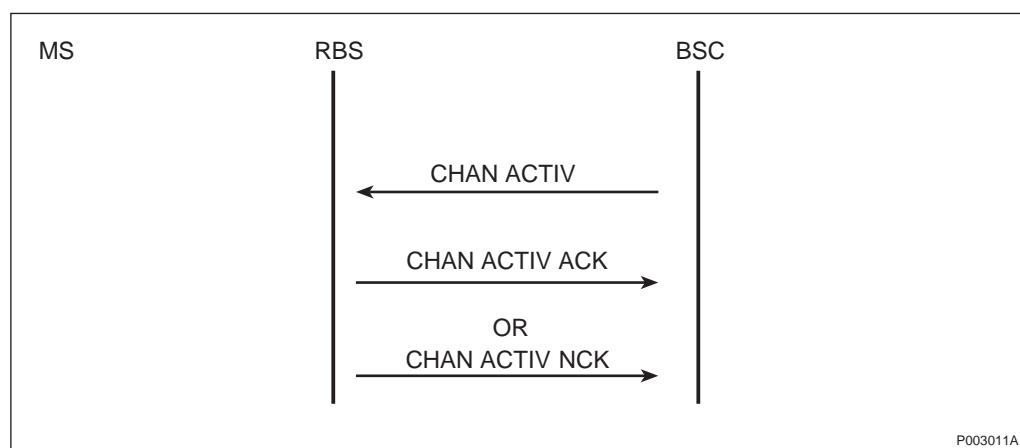

Figure 75

23.3 Adaptive Frame Alignment

Purpose

To ensure that the burst received in the RBS from an MSs is in time alignment.

Precondition and initiation

See Channel Activation above.

Description

This function ensures that the burst received in the RBS from an active MS at different distances from the RBS, is in time alignment. To ensure this, the RBS must inform the MS at which instant the MS shall start sending its bursts. /GSM 05.10:5/

Example

An MS is very close to a RBS. It is allocated on TS3 and only using this time slot for the call. During the call, the MS moves away from the RBS causing the information sent from the RBS to arrive at the MS later and later. The answer from the MS also arrives later and later at the RBS. This function prevents the delay becoming so long as to cause TS3 to overlap onto TS4, thus disturbing another call.

The function is terminated when the dedicated Resource Channels enter state IDLE.

There are three different kinds of Adaptive Frame Alignment:

1. Access Delay Measurement

From the start of normal burst reception on a dedicated channel, the RBS measures the Access Delay on all received bursts. These values are used at the calculation of a new ordered TA value to the MS, see Dynamic Time Alignment.

2. Initial Time Alignment

At start of downlink SACCH transmission, an initial ordered TA value (received at channel activation) is used in the L1 header of the SACCH block.

3. Dynamic Time Alignment

Three inputs are used to calculate the new/next TA order value included in the L1 header of the downlink SACCH block /GSM 04.04:7.1/:

- The access delay measurements on all normal bursts that are received since the last calculation (one SACCH reporting period)
- The actual used (by MS) TA value which is received in L1 header /GSM 04.04:7.2/ of the uplink SACCH block
- The previous/unit ordered TA value to MS

The ordered TA value must not be changed more than 1 step from the TA /GSM 05.10:5/ previously ordered.

23.4 Asynchronous Handover Detection

Purpose

To detect access bursts (in a handover situation).

Preconditions and initiation

See Channel Activation above.

Description

When the RBS is taking over the communication, in a handover situation, it has no information of the distance to the MS and consequently no Timing Advance information. The MS transmits access bursts. These bursts are kept very short (only 8 bits of information) in order to prevent disturbing another call. This function measures the delay of handover access burst received by the RBS and sets the Timing Advance. The information is included in the Physical_Information message to MS and the Handover_Detection message to BSC. /GSM 08.58:4.3/

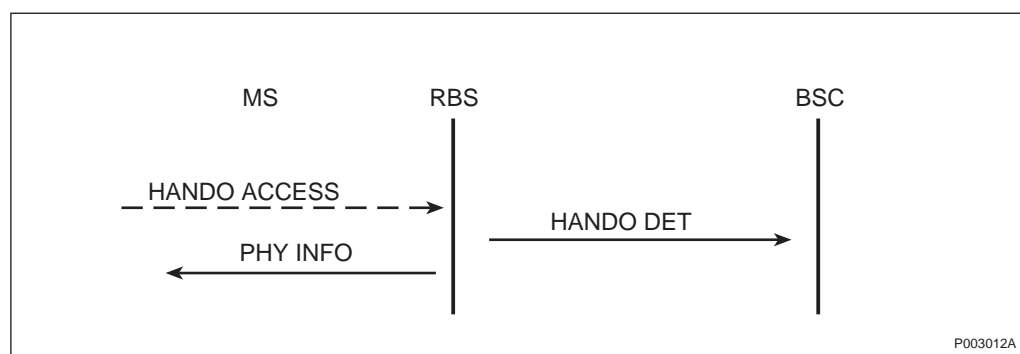

Figure 76

There are some criterias that have to be fulfilled if the Handover Access messages shall be accepted.

Acceptance of a Handover_Access message is based on:

- Handover Reference (received in handover message), which shall match the value received in the related Channel Activation from BSC
- Measured Access Delay, which must not exceed 63 (≥ 64 not accepted)

To accept the MS handover access, RBS shall receive:

- Two out of three acceptable Handover_Access messages (ABs) for channel combination (i)
- Two out of four acceptable Handover access messages (ABs) for channel combination (v) and (vii)

The TA difference between acceptable Access Bursts must be less than or equal to 4 bit periods.

On acceptance of the MS handover access, the RBS takes the following actions:

- Opens all logical channels for transceiving on the air (start Normal Burst reception) and starts active channel measurements on the dedicated resource
- Sends Handover detection to BSC /GSM 08.58:8.4.7/ including the measured access delay value

- Sends a Physical information message to the MS / GSM 04.08:3.4.4.2.2/. The Physical information shall be repeated.

If no correct frame is received from the MS, transmission of Physical information shall be repeated.

Example:

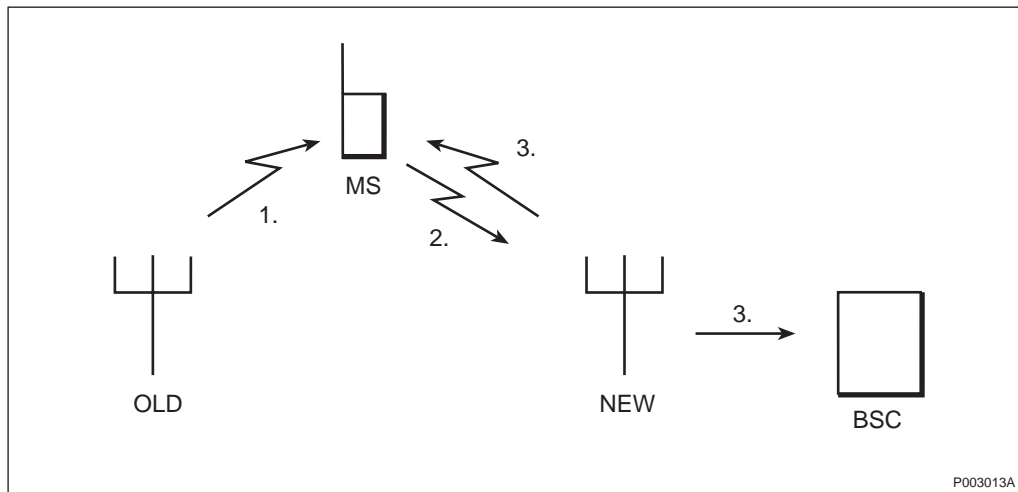

Figure 77

1. BSC sends a message to the MS through the old RBS containing information about the frequency and time slot to change to. This information is sent over FACCH.

2. The MS tunes to the new frequency, and transmits handover access bursts in the correct time slot. The access bursts are small enough to be sent without any Timing Advance information and do not disturb any other call.

3. (This function) RBS detects the handover access bursts and measures the delay. The delay gives information about the Timing Advance which is included in the Physical Information to the MS and the Handover Detection message to BSC.

23.5 RF Channel Release

Purpose

To release a radio channel which is no longer needed.

Precondition and initiation

See Channel Activation above.

The function is initiated when the RBS receives a Channel_Release message from BSC.

Description

All traffic and signalling on a group of dedicated logical channels are stopped, and all associated resources are released. After having released

the channel, or if the channel is already released, the RBS sends an RF_Channel_Acknowledge message to BSC /GSM 08.58:4.7/.

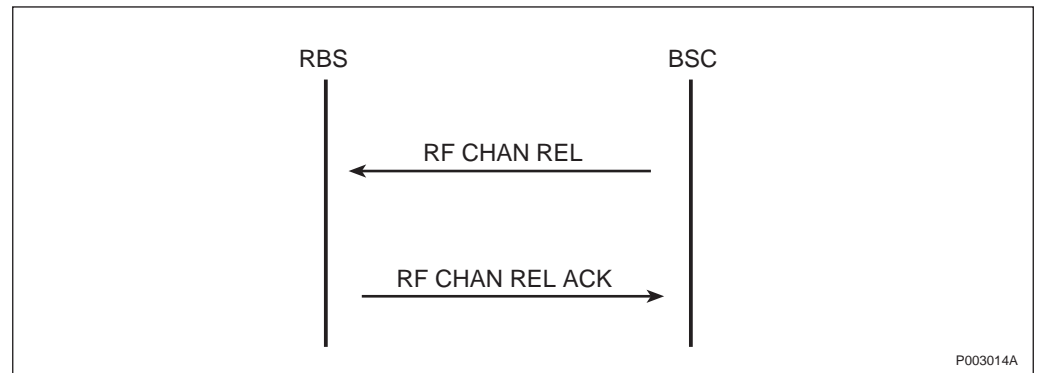

Figure 78

23.6 Deactivate SACCH

Purpose

To stop transmission on SACCH of the addressed channel group.

Precondition and initiation

See Channel Activation above.

The function is initiated when the RBS receives a Channel_Release message from BSC.

Description

The RBS immediately stops all transmission on SACCH of the addressed channel group. /GSM 08.58:4.6/

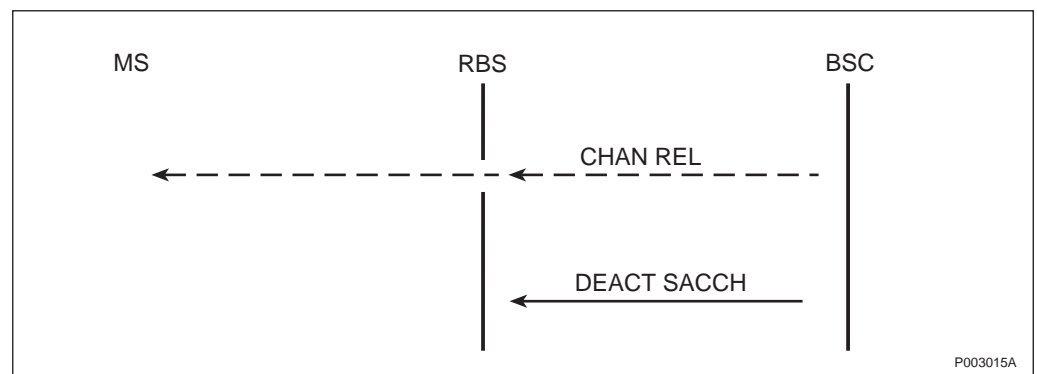

Figure 79

23.7 Link Establish Indication

Purpose

To establish a link layer connection between MS and network.

Precondition and initiation

Channel combination supported is defined in section Channel Activation above /GSM 04.06:5.4.4/.

The Link Establish Indication function is applicable for:

- SAPI-0 on SDCCH and FACCH
- SAPI-3 on SDCCH and FACCH/T

There are two cases of establishment as described in /GSM 04.06:5.4.1/:

- Normal establishment
- Contention resolution establishment

The function is initiated when the RBS receives an SABM from MS.

Description

The following procedure is used by RBS to indicate to BSC that a link layer on the air interface has been established by an initiative from the MS. After reception of a first SABM an indication (ESTablish INDication) is sent to the BSC that a link layer on the radio path has been established in multiframe mode.

It is the MS that takes initiative of the establishment. This is done when the mobile, for example, wants to send a measurement report to the network.

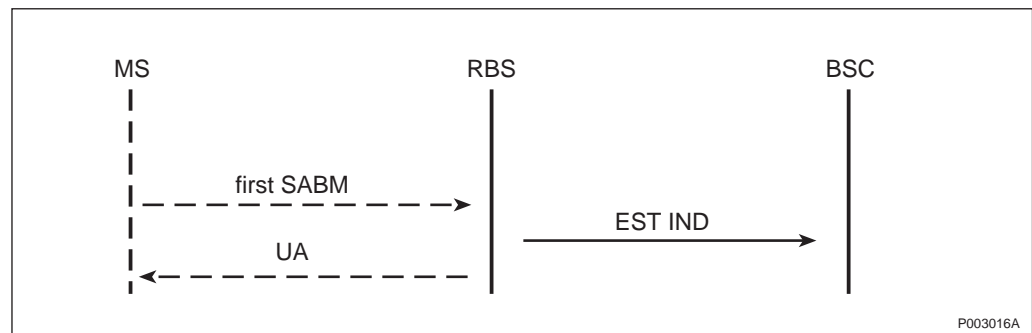

Figure 80

The Normal Establishment is utilized for SAPI-0 links (in conjunction with a normal assign or handover) as well as for SAPI-3 links (at SMS point-to-point).

The Contention Resolution Establishment is utilized for SAPI-0 links only (in conjunction with an immediate assign).

An attempt to establish an SAPI-3 link is rejected (Disconnect Mode response to MS if the SAPI-0 link is not established).

Messages queued for transmission are lost if the link is re-established.

- Collision cases are treated as specified in Technical Specification / GSM 04.06/
- Fault handling related to the link establish procedure is in accordance with /GSM 04.06:5.4.4/

- The link establishment procedure is in accordance with /GSM 08.58:3.1/ and /GSM 04.06:5.4.1/

23.8 Link Release Indication

Purpose

To release a link layer connection between MS and the network.

Precondition and initiation

Channel combination supported is defined in section Channel Activation above.

The Link Release Indication function is applicable for:

- SAPI-0 on SDCCH and FACCH
- SAPI-3 on SDCCH and FACCH/T

The function is initiated when the RBS receives a DISC frame from MS.

Description

The following procedure is used by RBS to indicate to BSC that a link layer on the air interface has been released by an initiative from the MS (disconnect). The MS sends a DISC frame on a link layer connection in multiframe mode. Multiframe mode means that an answer UA (unnumbered acknowledgment) is required. The RBS then sends a RELEase INDication message to BSC to confirm the release of the link layer. It is the mobile that takes initiative for the release. This is used when the signalling between MS and network is done and the link is no longer needed.

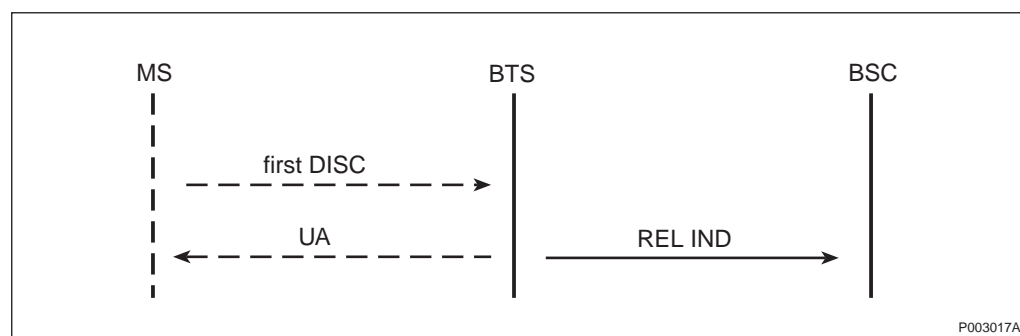

Figure 81

- The link release procedure is in accordance with /GSM 08.58:3.3/, /GSM 08.58:8.3.9/ and for RELEase INDication with /GSM 08.58:8.3.9/.
- Collision cases are treated as specified in Technical Specification GSM 04.06.
- Fault handling related to the link release procedure is in accordance with /GSM 04.06:5.4.4/.

23.9 Link Establishment Request

Purpose

To establish a signal link between MS and network.

Precondition and initiation

Channel combinations supported are defined in section Channel Activation above.

This function are applicable for:

- SAPI-3 links on SDCCH and SACCH/T

The function is initiated when the RBS receives an ESTablish REQuest from BSC.

Description

The following procedure is used by BSC to request the establishment of a link layer connection in multiframe mode on the air interface / GSM 08.58:3.2/.

The procedure starts when the RBS receives an ESTablish REQuest message from BSC. RBS then establishes the link by sending an SABM frame. Upon reception of the acknowledgment (UA-frame) from MS, RBS sends an ESTablish CONFirm message to BSC. It is the network (BSC) that takes initiative for the establishment. Measurement reports are one type of message which can be sent on the signal link.

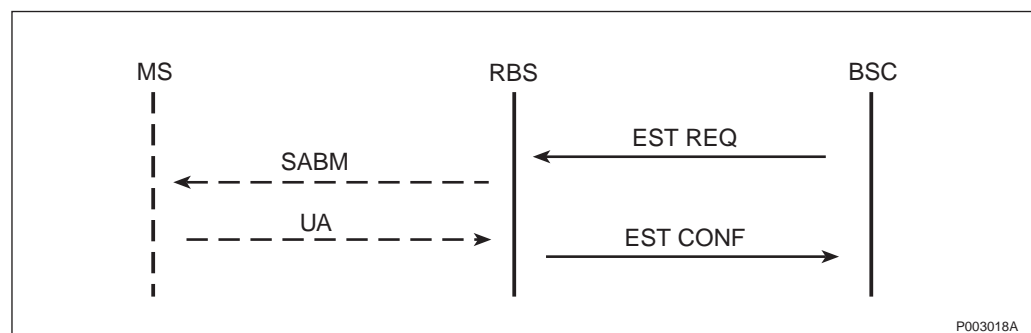

Figure 82

Messages queued for transmissions are lost if the link is re-established. When the link is established, an ESTablish CONFirm /GSM 08.58:3.5/ is to be sent to the BSC.

- The Link Establishment procedure is in accordance with / GSM 08.58:3.2/ and /GSM 04.06:4.1/.
- Fault Handling related to the link establishment procedure is in accordance with /GSM 04.06:5.4.1/.

23.10 Link Release Request

Purpose

To release a signal link between MS and network.

Precondition and initiation

Channel combinations supported are defined in section Channel Activation above.

This function are applicable for:

- SAPI-3 links on SDCCH and SACCH/M

The function is initiated when a RELease REQuEst is sent from BSC to RBS.

Description

The following procedure is used by BSC to request the release of a link layer connection on the air interface in multiframe mode / GSM 04.06:5.4.4/.

The procedure starts when the RBS receives a RELease REQuEst message from BSC. RBS then sends a DISC (disconnect) frame to MS. When it has received the acknowledgment (UA- or DM-frame), RBS sends an RELease CONFirm message to BSC.

It is the network (BSC) that takes initiative for the release. This is used when the signalling between MS and network is done and the link is no longer needed.

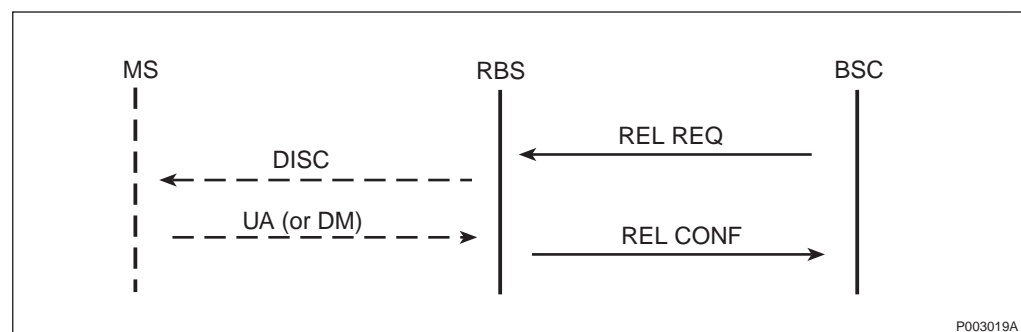

Figure 83

Messages queued for transmissions are lost if the link is re-established. When the link is established, an ESTablish CONFirm /GSM 08.58:3.5/ is to be sent to the BSC.

- The Link Release procedure is in accordance with / GSM 08.58:3.4/ and /GSM 04.06:5.4.4/.
- Fault Handling related to the link establishment procedure is in accordance with /GSM 04.06:5.4.4/.
- The RBS supports Normal Release as well as Local Release / GSM 04.06:5.4.4.4/.

23.11 Transparent Message Transmission

Purpose

To send transparent layer 3 information between MS and the network.

Precondition and initiation

Channel combinations supported are defined in section Channel Activation above.

This function are applicable for:

- SAPI-0 on SDCCH and FACCH
- SAPI-3 links on SDCCH and FACCH/T

The function is initiated when the RBS receives a RElease REQuest from BSC.

Description

The following procedure is used by BSC to send a layer 3 message to MS in acknowledged mode /GSM 08.58:3.5/. The message is sent through the RBS on the layer 2 link (the RBS is not affected by the message).

The function is initiated when a Data Request is received from BSC. The message contains the complete layer 3 message to be sent in acknowledged mode. The RBS sends the layer 3 message in accordance with /GSM 08.58:3.5/ to the MS inside an I (information field)-frame.

Transparent transmission in acknowledge mode requires that multiframe mode /GSM 08.58:3.1,3.2/ has been established. With multiframe mode means that an answer is needed. In this case an RR-frame (receiver ready) is sent back as a confirmation to the RBS.

The message is in this case sent from network (BSC) to MS. One example when this is used is for sending of SMS-message to the mobile.

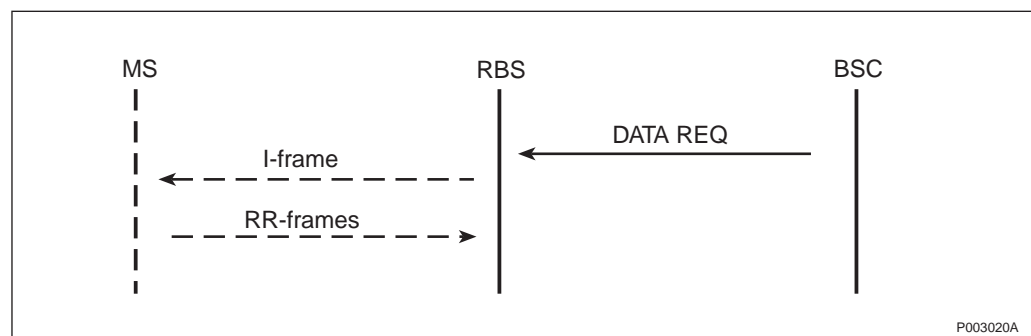

Figure 84

Transmission of SAPI-0 messages has higher priority than SAPI-3 messages. A separate queue for SAPI-3 messages (Short Message Service) exists.

23.12 Transparent Message Reception

Purpose

To send transparent layer 3 information between MS and the network.

Precondition and initiation

Channel combination supported is defined in section Channel Activation above.

This function are applicable for:

- SAPI-0 on SDCCH and FACCH
- SAPI-3 links on SDCCH and FACCH/T

The function is initiated when the RBS receives an I-frame from MS.

Description

The following procedure is used when the MS sends a transparent layer 3 message to RBS. The message is forwarded to the BSC. The message is sent through the RBS on the layer 2 link (the RBS is not affected by the message).

The RBS receives an I-frame containing the layer 3 message. When the message is received, an acknowledge (RR-frame) is sent back to the MS. RBS sends a Data Indication message to BSC. The message contains the received transparent layer 3 message from MS.

The message is in this case sent from mobile to network (BSC). One example when this is used is for sending an SMS-message to another subscriber.

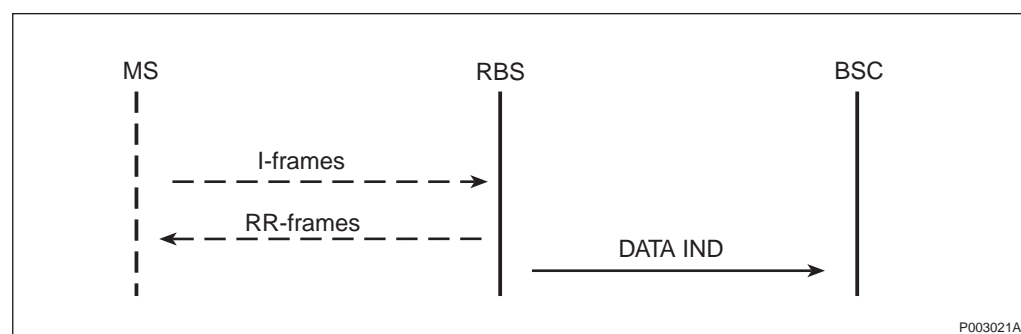

Figure 85

Transparent transmission in acknowledge mode requires that multiframe mode /GSM 08.58:3.1,3.2/ has been established. With multiframe mode means that an answer is needed. In this case an RR-frame (receiver ready) is sent back as a confirmation to the MS.

23.13 SACCH Info Modify

Purpose

To modify the SACCH information on an individual channel. The information from RBS is filtered so the unwanted data is removed.

Precondition and initiation

Channel combinations supported are defined in section Channel Activation above.

This function is initiated when the RBS receives a SACCH INFO MODIFY from BSC.

Description

This procedure is used by the BSC to modify the SACCH filling information (System Information) sent on an individual SACCH channel. For this purpose, the RBS receives a SACCH INFO MODIFY message from BSC. The SACCH filling information as given in the SACCH INFO MODIFY message shall be used on the indicated channel until the channel is released or the information is changed by another SACCH INFO MODIFY message.

The SACCH is used both uplink and downlink. On the uplink, the MS sends measurements on its own RBS (signal strength and quality) and neighbouring RBS (signal strength). On the downlink, the MS receives information concerning what transmitting power to use.

23.14 LAPDm

Purpose

To provide a reliable signalling link.

Precondition and initiation

Channel combinations supported are defined in section Channel Activation above.

LAPDm supports two modes of operation:

- unacknowledged
- acknowledged

Both SAPI-0 and SAPI-3 are supported; establishment of SAPI-3 requires that SAPI-0 is established.

SAPI-0

SAPI-0 is used for Call Control, Mobility Management and Radio Resource Management Signalling. The following channels are supported:

| | |
|-------------|--|
| BCCH + CCCH | Downlink. Unacknowledged mode is supported. |
| SDCCH | Acknowledged and unacknowledged modes are supported. |
| FACCH | Acknowledged and unacknowledged modes are supported. |
| SACCH/C | Unacknowledged mode is supported |
| SACCH/T | Unacknowledged mode is supported. |

SAPI-3

SAPI-3 is used for S MS point-to-point. The following channels are supported:

| | |
|---------|---------------------------------|
| SDCCH | Acknowledged mode is supported. |
| SACCH/T | Acknowledged mode is supported. |

Description

LAPDm (Link Access Procedure on the Dm-channel) is a protocol that operates at the data link layer of the OSI structure. It receives service from the physical link (layer 1) and provides services to the net (layer 3).

The LAPDm function denotes the overall functionality included in the LAPDm protocol and the radio link layer management procedures. LAPDm conforms to /GSM 04.06/.

This function is used to send signalling information in between MS and RBS on the air interface.

23.15 Channel Reactivation**Purpose**

To reactivate an already activated, dedicated channel resource with new parameters.

Precondition and initiation

The function is initiated when a CHANNEL_ACTIVATION / GSM 08.58:4.1/ message is received from BSC.

Supported channel combinations /GSM 05.02:6.4/

- (i) TCH/F + FACCH/F + SACCH/TF
- (ii) TCH/H(0.1) + FACCH/H(0.1) + SACCH/TH(0.1)
- (v) FCCH + SCH + BCCH + CCCH + SDCCH/4[0...3] + SACCH/C4[0...3]
- (vii) SDCCH/8[0...7] + SACCH/C8[0...7]
- (viii) TCH/F + FACCH/F + SACCH/M
- (ix) TCH/F + SACCH/M
- (x) TCH/FD + SACCH/MD

Supported channel numbers /GSM 08.58:9.3.1/

- Bm + ACCHs
- Lm + ACCHs
- SDCCH/4 + ACCH
- SDCCH/8 + ACCH

Supported reactivation types /GSM 08.58:9.3.3/

- Immediate Assign
- Normal Assign
- Asynchronous Handover

Supported channel modes /GSM 08.58:9.3.6/

| | |
|--------|---|
| TCH/F | Signalling |
| TCH/H | Signalling |
| TCH/FS | Full rate speech, GSM speech alg. Ver 1 |
| TCH/FS | Full rate speech, GSM speech alg. Ver 2 |
| TCH/HS | Half rate speech |
| SDCCH | Signalling |

For the non-transparent service

| | |
|----------|---|
| TCH/F9.6 | Full rate data 9.6 kbit/s non-transparent |
| TCH/H4.8 | Half rate data 4.8 kbit/s non-transparent |

For the transparent service

| | |
|----------|---|
| TCH/F9.6 | Full rate data 9.6 kbit/s transparent |
| TCH/F4.8 | Full rate data 4.8 kbit/s transparent |
| TCH/F2.4 | Full rate data 2.4 kbit/s transparent |
| TCH/F2.4 | Full rate data 1.2 kbit/s transparent |
| TCH/F2.4 | Full rate data 600 bit/s transparent |
| TCH/F2.4 | Full rate data 1200/75 bit/s (1200 network >MS, 75 MS >network) transparent |
| TCH/F | Signalling, Bi-directional (not allowed on channel combination ix) |
| TCH/FS | Full rate speech, GSM speech alg. Ver 1, Bi-directional |
| TCH/FS | Full rate speech, GSM speech alg. Ver 2, Bi-directional |
| TCH/F9.6 | Full rate data 9.6 kbit/s non-transparent, Bi-directional |
| TCH/H4.8 | Half rate data 4.8 kbit/s non-transparent, Bi-directional |

| | |
|----------|---|
| TCH/F9.6 | Full rate data 9.6 kbit/s transparent, Bi-directional |
| TCH/F4.8 | Full rate data 4.8 kbit/s transparent, Bi-directional |
| TCH/F2.4 | Full rate data 2.4 kbit/s transparent, Bi-directional |
| TCH/F2.4 | Full rate data 1.2 kbit/s transparent, Bi-directional |
| TCH/F2.4 | Full rate data 600 bit/s transparent, Bi-directional |
| TCH/F2.4 | Full rate data 1200/75 bit/s transparent, Bi-directional |
| TCH/FS | Full rate speech, GSM speech alg. Ver 1, Uni-directional |
| TCH/FS | Full rate speech, GSM speech alg. Ver 2, Uni-directional |
| TCH/F9.6 | Full rate data 9.6 kbit/s non-transparent, Uni-directional |
| TCH/H4.8 | Half rate data 4.8 kbit/s non-transparent, Uni-directional |
| TCH/F9.6 | Full rate data 9.6 kbit/s transparent, Uni-directional |
| TCH/F4.8 | Full rate data 4.8 kbit/s transparent, Uni-directional |
| TCH/F2.4 | Full rate data 2.4 kbit/s transparent, Uni-directional |
| TCH/F2.4 | Full rate data 1.2 kbit/s transparent, Uni-directional |
| TCH/F2.4 | Full rate data 600 bit/s transparent, Uni-directional |
| TCH/F2.4 | Full rate data 1200/75 bit/s transparent, Uni-directional |
| TCH/H4.8 | Half rate data 4.8 kbit/s non-transparent |
| TCH/H4.8 | Half rate data 4.8 kbit/s transparent |
| TCH/H2.4 | Half rate data 2.4 kbit/s transparent |

| | |
|----------|---|
| TCH/H2.4 | Half rate data 1.2 kbit/s transparent |
| TCH/H2.4 | Half rate data 600 bit/s transparent |
| TCH/H2.4 | Half rate data 1200/75 bit/s (1200 network >MS, 75 MS >network) transparent |

Note: TCH/F4.8 non-transparent is only hardware supported.

Classification (see section Concepts) of elements, common for all activation types

| | |
|------------------------|----------|
| Channel Identification | Ignored |
| BS Power | Optional |
| MS Power | Required |
| BS Power Parameters | Rejected |
| MS Power Parameters | Rejected |
| Physical Context | Rejected |

Normal Assignment /GSM 08.58:4.1/

The optional elements for Normal Assignment are:

| | |
|------------------------|----------|
| Encryption Information | Optional |
| Handover Reference | Rejected |
| Timing Advance | Required |
| SACCH Information | Optional |

If the parameter SACCH Information is present, the contents will be used for this channel group instead of the information received in the SACCH FILLING INFORMATION MODIFY procedure described in Broadcast.

Multislot configuration (secondary channels) /GSM 08.58:4.1/

The reactivation for the multislot configuration procedure is in accordance with /GSM 08.58:4.1/.

| | |
|------------------------|----------|
| Encryption Information | Optional |
| Handover Reference | Rejected |
| Timing Advance | Rejected |
| SACCH Information | Optional |

If the parameter SACCH Information is present, the contents will be used for this channel group instead of the information received in the SACCH FILLING INFORMATION MODIFY procedure described in Broadcast.

Description

The RBS receives a Channel_Activation message from BSC, in order to reactivate an already activated channel between MS and RBS. The RBS reactivates the channel with new parameters. /GSM 08.58:4.6/

During the reactivation, information flows are not interrupted.

If the reactivating of the channel is successful, the RBS answers with Channel_Activation_Acknowledgement. Otherwise, if the channel for some reason cannot activate, the answer is a Channel_Activation_Negative_Acknowledgement.

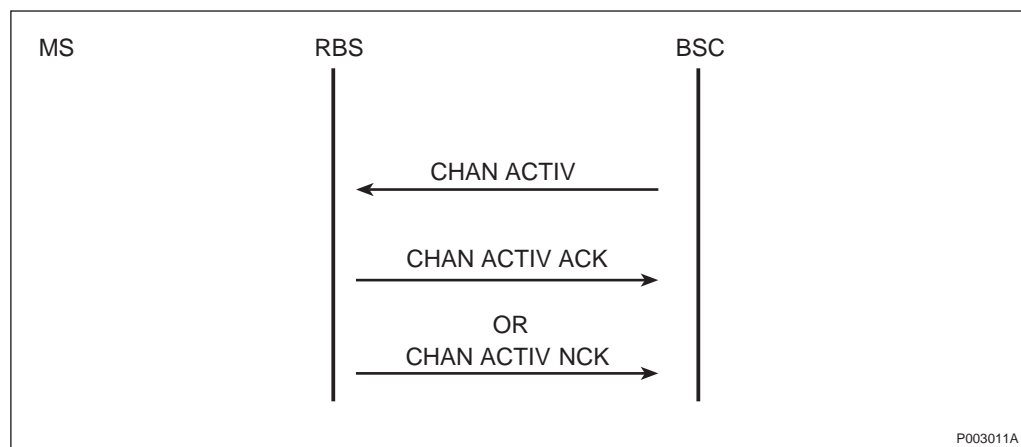

Figure 86

23.16 Power Information

Purpose

To change output power on the air interface between RBS and MS.

Precondition and initiation

Transparent transmission in acknowledged mode requires that multiframe mode has been established.

The function is initiated when a DATA REQUEST message containing information element Power Information is received by the RBS.

Description

By means of the POWER INFORMATION element, the transmission power of the RBS and the MS is immediately changed. It is an optional part of the DATA REQUEST message on Abis. /GSM 08.58:8.3.1/ The power information element contains the new power levels to be used by the RBS (BS Power Level) and the MS (MS Power Level) on the air interface.

The RBS will immediately, without waiting for the next measurement period, change output power to BS Power Level. The MS Power Level will be sent to the MS in the L1 header on SACCH as soon as possible.

If the RBS receives a value that would result in a setting below the lowest allowed level, the power is set to the lowest allowed level.

The function is terminated when Power Information has been acknowledged according to the LAPDm protocol.

24 Base Station Power Control

This document covers power regulation by means of the CHANNEL_ACTIVATION and BS_POWER_CONTROL messages from the BSC.

The "Base Station Power Control" function is implemented to minimise the transmit power required by the RBS TRXs (transceivers), while maintaining the quality of the radio link.

24.1 References

/GSM:05.02/ GSM 05.02 (phase 2) version 4.3.0

/GSM:05.05/ GSM 05.05 (phase 2) version 4.6.0

/GSM:05.08/ GSM 05.08 (phase 2) version 4.6.0

/GSM:08.58/ GSM 08.58 (phase 2) version 4.2.0

Whenever a reference is made to a function described in another chapter, please refer to the table of contents to find the appropriate chapter.

24.2 Concepts

Nominal Power The power level defined during configuration of the RBS TRXs.

24.3 Functions

24.3.1 Base Station Power Control at Channel Activation

By means of the TRANSMISSION POWER CONTROL procedure / GSM:08.58:4.9/, the BSC defines the TRX (transceiver) transmission power level.

The RBS supports:

- Interpretation of the BS Power information element in the CHANNEL_ACTIVATION message from BSC
- Storage of BS Power
- Adjustment of BS Power level

Supported Channel Numbers /GSM:08.58:9.3.1/:

- Bm + ACCHs
- Lm + ACCHs
- SDCCH/8 + ACCH
- SDCCH/4 + ACCH

Supported Channel combinations /GSM:05.02:6.4/:

- (i) TCH/F + FACCH/F + SACCH/TF
- (ii) TCH/H(0.1) + FACCH/H(0.1) + SACCH/TH(0.1)

- (v) $FCCH+SCH+BCCH+CCCH+SDCCH/4(0..3)+SACCH/C4(0..3)$
- (vii) $SDCCH/8(0..7) + SACCH/C8(0..7)$
- (viii) $TCH/F + FACCH/F + SACCH/M$
- (ix) $TCH/F + SACCH/M$
- (x) $TCH/FD + SACCH/MD$

The nominal power level is used if BS Power is not received at channel activation. The "BS Power" received is stored in the RBS to be used for the requested dedicated channel.

The RBS is able to reduce its BS power level (starting from the nominal power level) in up to 15 steps of 2 dB (nominal value), as defined by the BSC.

If the RBS receives a BS Power which would result in a setting below the lowest level allowed, the BS power level is tuned into the lowest level allowed. The maximum BS power level used for a specific channel never exceeds the nominal BS power level.

The commanded BS Power level is applied on each transmitted burst, except for bursts on a BCCH carrier, where the nominal BS Power level is used on all timeslots. An attempt to change the BS Power level for a channel on a BCCH carrier, is accepted but has no effect.

24.3.2 Base Station Power Control for an Active Channel

By means of the TRANSMISSION POWER CONTROL procedure / GSM:08.58:4.9/ the BSC defines the TRX transmission power level.

The RBS support:

- Interpretation of BS_POWER_CONTROL message from BSC
- Storage of BS Power
- Adjustment of BS power level

Supported channel numbers, channel combinations and handling of the received BS power level are as described in chapter Base Station Power Control, see table of contents.

The BS power change starts at the first TDMA frame belonging to a SACCH reporting period. When the RBS has received a new BS power level, the BS power is changed within two SACCH reporting periods

24.3.3 Base Station Power Control at Channel Reactivation

See Section 24.3.1 on page 275.

24.4 Operational Conditions

The power level setting follows /GSM:05.05:4.1.2/, according to power level step size, maximum output power and tolerances.

25 Channel Measurements

The RBS supports:

- Active Channel Measurements, that is quality and signal strength measurements on active uplink dedicated channels.
- Idle Channel Measurements, that is signal strength measurements on idle uplink dedicated channels.

25.1 References

| | |
|-------------|------------------------------------|
| /GSM:08.58/ | GSM 08.58 (phase 2) version 4.7.0 |
| /GSM:05.08/ | GSM 05.08 (phase 2) version 4.12.0 |
| /GSM:05.02/ | GSM 05.02 (phase 2) version 4.4.2 |

Whenever a reference is made to a function described in another chapter, please refer to the table of contents to find the appropriate chapter.

25.2 Concepts

| | |
|--------------------|--|
| RX Reference Point | Defined as the point where the RX antenna signal crosses the RBS border, that is the connector for the antenna feeder. |
| Reporting Period | TDMA frames used for measurements, as defined in /GSM 05.08:8.4/. |
| RXLEV | Measure of signal strength as defined in /GSM 05.08:8.1.4/. |
| RXLEV_FULL | RXLEV measured over a whole SACCH multiframe. |
| RXLEV_SUB | RXLEV measured over a subset of a SACCH multiframe. |
| RXQUAL | Measure of signal quality as defined in /GSM 05.08:8.2.4/. |
| RXQUAL_FULL | RXQUAL measured over a whole SACCH multiframe. |
| RXQUAL_SUB | RXQUAL measured over a subset of a SACCH multiframe. |

25.3 Functions

25.3.1 Active Channel Measurements

By means of the basic measurement reporting procedure /GSM:08.58:4.5.1/, the RBS performs quality and signal strength measurements on all active uplink dedicated channels. Measurements on channel combinations, (i), (ii), (v) and (vii) are supported, /GSM:05.02:6.4/.

The RBS measures BER (Bit Error Rate) and the signal strength over each active channel per reporting period. All SACCH frames are included in the measurements.

The reporting periods are different for different TNs, and for different channels, and are the same as for the MS, defined in /GSM 05.08:8.4/.

The measurements of signal strength are referred to the RX reference point. An R.M.S. (Root Mean Square) value is created for each burst. Then, the logarithm of this value, expressed in dBm, is averaged over the reporting period. The mapping of this average and RXLEV is as defined in /GSM 05.08:8.1.4/.

The signal quality measurements are sampled per reporting period.

The mapping between BER and RXQUAL is as defined in /GSM 05.08:8.2.4/.

RBS calculates RXLEV_FULL, RXLEV_SUB, RXQUAL_FULL and RXQUAL_SUB as an average of the frames as defined in the following table:

Table 108 Frame calculation

| Channel combination | RXQUAL_FULL, RXLEV_FULL | RXQUAL_SUB, RXLEV_SUB |
|---------------------|---|---|
| (i) | All TCH and SACCH frames (96 TCH, 4 SACCH) | 8 SID + 4 SACCH |
| (ii) | All TCH and SACCH frames (48 TCH, 4 SACCH) | TCH/S: 8 SID + 4 SACCH |
| | | TCH/Data: 10 SID + 4 SACCH |
| (v), (vii) | All SDCCH and SACCH frames (8 SDCCH, 4 SACCH) | Same frames as for RXLEV_FULL and RXQUAL_FULL |
| (viii), (ix) | All TCH and SACCH frames (96 TCH, 4 SACCH) | 8 SID + 4 SACCH |
| (x) | Channel measurements are unspecified | |

The SID frames for the TCH channels are defined in /GSM 05.08:8.3/.

Results from channel measurements are reported by A-bis message MEASUREMENT_RESULT /GSM 08.58:8.4.8/.

25.3.2 Idle Channel Measurements

The RBS can perform signal strength measurements of disturbances on all idle uplink dedicated channels.

The function is set to on or off on full rate or half rate basis when the TS is configured by the BSC.

Measurements of signal strength are made over an averaging period. The averaging period specifies the number of measurement periods from which an average value is to be calculated. The averaging period is specified for each TS by the BSC.

The measurements of signal strength are referred to the RX reference point. An R.M.S. value is formed for each timeslot. The logarithm of

this value, expressed in dBm, is coded as defined for RXLEV in /GSM 05.08:8.1.4/. The average value is calculated from the RXLEV value, After Initiation, a first average value is calculated after two completed measurement periods. The second value is calculated when the first averaging period is completed.

After this, a new average value is calculated after each new measurement, that is a sliding window principle is used where the oldest value within the averaging period is replaced by the new one.

The average value is classified into one of five Interference Level Bands.

Results from idle channel measurements are reported via the Abis message RF_RESOURCE_INDICATION /GSM 08.58:8.6.1/. This is done when the first value has been calculated and thereafter when the calculated average value is classified into a new Interference Level Band.

25.4 Operational Conditions

The measurements of R.M.S. signal level fulfil the requirements in /GSM:05.08:8.1.2/. When applicable, exceptions are stated within the context of Radio Reception.

The measurements of RXQUAL fulfil the requirements in /GSM 05.08:8.2/, that is for BER from < 0.2% to > 12.8%.

The MEASUREMENT_RESULT message and the RF_RESOURCE_INDICATION message are sent during the following reporting period.

This page is intentionally left blank

26 Discontinuous Transmission

"Discontinuous Transmission" is a mechanism which allows the radio transmitter to be switched off during speech or data (non-transparent) pauses.

The following benefits are achieved:

- Power is saved in the MS uplink
- The overall interference level on the air is reduced
- Reduced RBS power consumption downlink

The RBS supports downlink DTX (Discontinuous Transmission) as well as uplink DTX.

26.1 References

| | |
|-------------|-----------------------------------|
| /GSM:04.06/ | GSM 04.06 (phase 2) version 4.1.0 |
| /GSM:04.21/ | GSM 04.21 (phase 2) version 4.2.1 |
| /GSM:05.02/ | GSM 05.02 (phase 2) version 4.3.0 |
| /GSM:05.08/ | GSM 05.08 (phase 2) version 4.6.0 |
| /GSM:06.12/ | GSM 06.12 (phase 2) version 4.0.1 |
| /GSM:06.22/ | GSM 06.22 (phase 2) version 4.0.0 |
| /GSM:06.31/ | GSM 06.31 (phase 2) version 4.0.0 |
| /GSM:06.32/ | GSM 06.32 (phase 2) version 4.0.1 |
| /GSM:06.41/ | GSM 06.41 (phase 2) version 4.0.0 |
| /GSM:06.42/ | GSM 06.42 (phase 2) version 4.0.0 |
| /GSM:06.81/ | GSM 06.81 (phase 2) (t.b.d) |
| /GSM:08.20/ | GSM 08.20 (phase 2) version 4.1.0 |

Whenever a reference is made to a function described in another chapter, please refer to the table of contents to find the appropriate chapter.

26.2 Functions

26.2.1 DTX Downlink

The DTX function is described in:

| | |
|-------------|---|
| /GSM:06.12/ | Comfort Noise Aspects |
| /GSM:06.22/ | Comfort Noise Aspects (half rate speech) |
| /GSM:06.31/ | Overall DTX Operation (full rate speech) |
| /GSM:06.32/ | Voice Activity Detection (full rate speech) |
| /GSM:06.41/ | Overall DTX Operation (half rate speech) |

| | |
|-------------|---|
| /GSM:06.42/ | Voice Activity Detection (half rate speech) |
| /GSM:06.81/ | Overall DTX Operation (enhanced full rate speech) |

The downlink DTX function is supported for channel modes:

- TCH speech, full rate (GSM speech alg. version 1), uni-directional
- TCH speech, full rate (Speech full rate version 2), uni-directional
- TCH speech, full rate (GSM speech alg. version 1), bi-directional
- TCH speech, full rate (Speech full rate version 2), bi-directional
- TCH speech, half rate
- TCH data, 9.6 kbit/s, non-transparent, uni-directional
- TCH data, 4.8 kbit/s, non-transparent (Only half rate supported)
- TCH data, 9.6 kbit/s, non-transparent, bi-directional

For all other Channel Modes, the DTXd indicator is ignored, since the DTX function is not applicable.

Channel combinations supported /GSM:05.02:6.4/:

- (i) TCH/F + FACCH/F + SACCH/TF
- (ii) TCH/H(0,1) + FACCH/H(0,1) + SACCH/TH(0,1)
- (viii) TCH/F + FACCH/F + SACCH/M
- (ix) TCH/F + SACCH/M
- (x) TCH/FD + SACCH/MD

The downlink DTX function is enabled when a CHANNEL_ACTIVATION message, or a MODE_MODIFY message with the DTX downlink indicator set, is received from the BSC.

The downlink DTX function for speech is initiated when a speech frame containing comfort noise parameters, is received from the RTC (Remote Transcoder).

The downlink DTX function for non-transparent data is initiated when a complete RLP (Radio Link Protocol) frame, with all E1-bits/ GSM:04.21/ set to 1, is received from the RTC.

DTX handling speech

The usage of downlink DTX (ON/OFF) is indicated (as a flag) in the full rate RTH-SPEECH-IND/RTH-E-SPEECH-IND, half rate RTH-SPEECH-IND and RTH- IDLE SPEECH-IND frames to the RTC. To detect if a full rate RTH-SPEECH-IND/RTH-E-SPEECH-IND or half rate RTH-SPEECH-IND frame (received from the RTC) contains speech or comfort noise parameters /GSM:06.32 / or /GSM:06.42/, RBS analyses the SID code word /GSM:06.12:5.2/, /GSM:06.62:5.3/ or /GSM:06.22:5.3/.

SID frames (including comfort noise parameters) are scheduled in TDMA frames according to /GSM:05:08:8.3/. When a SID frame is stolen for signalling (FACCH) purposes, the scheduling in TDMA

frames will instead be according to /GSM:06.31:5.1.2/, /GSM:06.41:5.1.2/ or /GSM:06.81:5.1.2/.

The output power is turned off during periods of silence, except in the following cases:

- Transmission of SID frames (comfort noise parameters)
- Transmission of signalling (FACCH)
- Transmission on a C0 carrier (dummy bursts)
- Transmission on a transmitter configured for filling (dummy bursts)

DTX handling non-transparent data

To detect idle data transmission in the downlink direction, the E1-bits of a complete RLP frame received from the RTC, are analysed /GSM:08.20:4.2/. This frame is not transmitted on the air interface.

When idle data transmission is detected, an L2 (Layer 2 protocol) fill frame /GSM:04.06:5.4.2.3/ is transmitted (on FACCH) in the SID positions of the TDMA frame according to /GSM:05:08:8:3/.

The output power is turned off during periods of idle data transmission, as described in the section DTX handling speech above.

26.2.2 DTX Uplink

The DTXu indicator (of element Channel Mode) in the CHANNEL_ACTIVATION or MODE_MODIFY messages from the BCS is ignored, since the RBS is always prepared to handle uplink DTX.

The uplink DTX function is supported for the following services:

- TCH speech, full rate (GSM speech alg. version 1)
- TCH speech, full rate (Speech full rate version 2)
- TCH speech, half rate (GSM speech alg. version 1)
- TCH speech, full rate (GSM speech alg. version 1) bidirectional
- TCH speech, full rate (Speech full rate version 2) bidirectional

Data frames (transparent and non-transparent) are passed transparently from the MS to the RTC without consideration to DTX.

To detect if a speech frame (received from MS) contains speech or comfort noise parameters, RBS analyses the SID code word /GSM:06.12:5.2/, /GSM:06.62:5.3/ or /GSM:06.22:5.3/. An indication of comfort noise parameters (SID flag), is sent in the full rate RTH-SPEECH-IND/RTH-E-SPEECH-IND or half rate RTH-SPEECH-IND frames to the RTC.

Full Rate

During periods of silence, RTH-SPEECH-IND with the silence indicator (SID) set to “3” are sent to the RTC in case when GSM speech alg. version 1 are used.

If, during periods of silence, Speech full rate version 2 are used, RTH-SPEECH-IND frames are sent to the RTC with the BFI set.

Half Rate

During periods of silence, RTH-SPEECH-IND frames are sent to the RTC with the BFI set.

27 Encryption

Encryption is used for ciphering and deciphering of information to and from an MS over a dedicated resource. The RBS supports two encryption modes, either using no encryption or using a GSM encryption algorithm.

The BSC controls which encryption mode is used.

There are two product variants with different encryption algorithms implemented:

- No encryption — GSM encryption algorithm version 1 (A5/1).
- No encryption — GSM encryption algorithm version 2 (A5/2).

27.1 References

| | |
|-------------|-----------------------------------|
| /GSM 04.08/ | GSM 04.08 (phase 2) version 4.7.0 |
| /GSM 08.58/ | GSM 08.58 (phase 2) version 4.7.0 |

Whenever a reference is made to a function described in another chapter, please refer to the table of contents to find the appropriate chapter.

27.2 Start Encryption at Channel Activation

Purpose

To initiate encryption mode on a dedicated logical channel.

Precondition and initiation

The function starts encryption if element "Encryption Information" is provided in the "CHANNEL_ACTIVATION" message.

Element "Encryption Information" is optional when the Channel Activation types are:

- Normal Assign
- Asynchronous Handover
- Synchronous Handover
- Multislot Configuration

Element "Encryption Information" is not supported for Channel Activation type "Immediate Assign".

Access burst, which is received from MS at handover access, is not deciphered.

- Supported channel numbers: /GSM 05.02:6.4/
- Bm + ACCH
- Lm + ACCH
- SDCCH/8 + ACCH
- SDCCH/4 + ACCH (and TN=0)

This function is initiated during the set up of an encrypted channel between MS and RBS. The BSC controls initiation of encryption mode.

Description

To set up a dedicated logical channel, encryption mode has to be set. The RBS supports two encryption modes, "No encryption shall be used" and "encryption" (encrypted by a specific GSM encryption algorithm), see /GSM 08.58/. The RBS receives information of which encryption mode to use, from BSC in a Channel_Activation message containing "Encryption Information" (via ABIS RSL interface). This command starts the function, and the traffic channel is encrypted according to chosen algorithm.

The function is terminated when a "Channel_Activation_Acknowledge" is sent to BSC.

27.3 Encryption Mode Change

Purpose

This function is used to change the encryption mode (key and algorithm) on an established dedicated channel.

Precondition and initiation

Encryption Mode change is defined in the section above.

This function is initiated when RBS receives an Encryption Command from BSC.

Description

The RBS starts deciphering when the encryption command is received. A Ciphering Mode Command is sent to start the encryption at the MS. The MS then sends a Ciphering Mode Complete /GSM 04.08:-9.1.10/ as an acknowledgement to the RBS.

When the RBS receives a Ciphering Mode Complete, the encryption is initiated in the network, and a DI (Data Indication) is sent back to the BSC.

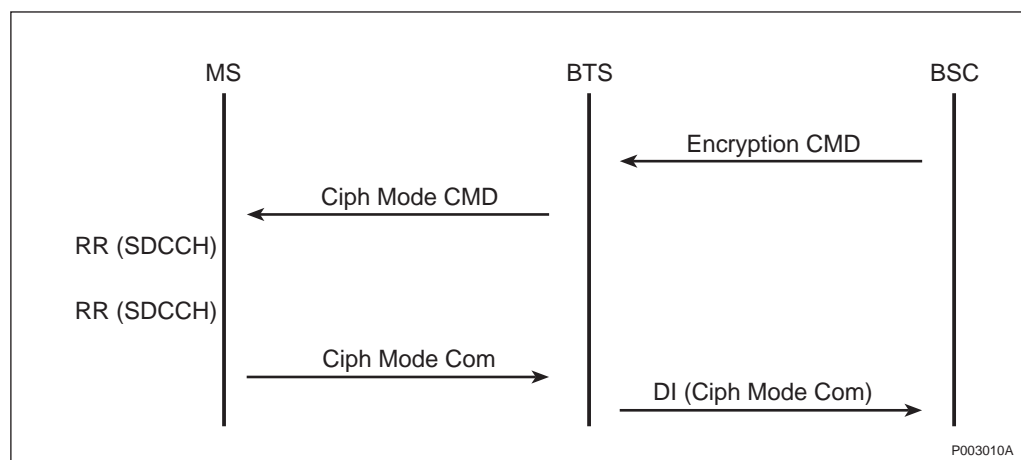

Figure 87

27.4 Encryption Mode Change at Mode Modify

Purpose

This function is used to change the encryption mode (key and algorithm) on an active dedicated channel group.

Preconditions and initiation

Encryption is either activated or deactivated.

The function is initiated when the RBS receives a `MODE_MODIFY_COMMAD` message from BSC.

Description

The message (`MODE_MODIFY_COMMAD`) contains the new key and algorithm to use. The ciphering key and algorithm identifier can be changed to any valid value.

If "Algorithm Identifier" is "No encryption shall be used", the RBS updates the key by clearing the stored key and ciphering is stopped / GSM 04.08:3.4.7/.

This page is intentionally left blank

28 Frequency Hopping

"Frequency hopping" means that the radio frequency channel of a BPC may change on a per TDMA frame basis. Frequency hopping improves the quality of the transmission on the air interface.

The Frequency hopping function is used to increase the efficiency of the channel coding and interleaving in the following situations:

- Multipath (or Rayleigh) fading
 - Is often frequency-dependent. In case of a dip, changing of frequencies reduces this problem.
- Interference problems
 - Without frequency hopping, a connection may experience high interference for a long time. With frequency hopping this time is shortened. However, frequency hopping does not reduce the overall system interference level, but averages it.

There are two types of frequency hopping available:

- Baseband hopping
- Synthesizer hopping

28.1 References

/GSM 08.58/ GSM 08.58 (phase 2) version: 4.2.0

/GSM 05.02/ GSM 05.02 (phase 2) version: 4.3.0

Whenever a reference is made to a function described in another chapter, please refer to the table of contents to find the appropriate chapter.

28.2 Concepts

Baseband Hopping Each transmitter will always transmit on the same frequency. The physical channel data will be sent from different transmitters with every burst.

Synthesizer Hopping The physical channel data will be sent from the same transmitter all the time. But the transmitter will use a new frequency with every burst.

28.3 Function

Frequency hopping is provided on a slot-by-slot basis according to /GSM:05.02.6.2/.

Supported channel combinations /GSM:05.02:6.4/:

- (i) TCH/F+FACCH/F+SACCH/TF
- (ii) TCH/H(0,1) + FACCH/H(0,1) + SACCH/TH(0,1)
- (vii) SDCCH/8 [0..7]+SACCH/C8 [0..7]

Supported channel numbers are:

- Bm + ACCH
- Lm + ACCH
- SDCCH/8 + ACCH

This function is initiated when a CHANNEL_ACTIVATION message / GSM:08.58:8.4.1/ is received from the BSC.

The information element Channel Identification as defined in / GSM:08.58:9.3.5/ is ignored.

The BPC must have already been configured for frequency hopping by the BSC (OML link). All frequency hopping parameters are defined for each BPC at configuration, and cannot be changed at channel activation.

Frequency hopping is performed according to /GSM: 05.02:6.2.3/. Frequency hopping is not supported for the BPC carrying BCCH.

Other BPCs on the BCCH frequency can be frequency hopping when baseband hopping is used. The following configuration parameters are used for administration of frequency hopping, the parameters are used in the frequency hopping algorithms as described in /GSM: 05.02:6.2.3/.

Table 109 Configuration parameters

| Parameter | Supported values | Description |
|----------------|--------------------|--|
| HSN | /GSM: 05.02 6.2.2/ | Hopping Sequence Number 0 = cyclic hopping 1-63 = random hopping |
| MAIO | /GSM: 05.02:6.2.2/ | Mobile Allocation Index Offset |
| Frequency list | 1-64 fields | Information element to provide a list of the ARFCNs used in a frequency hopping sequence |

28.4 Operational Conditions

Both baseband and synthesizer frequency hopping are supported. A maximum of 64 frequencies can be used in the hopping sequence.

29 Mode Modify

The "Mode Modify" procedure is used by BSC to request a change of the channel mode (speech to data, data to speech, etc.) of an active channel.

29.1 References

/GSM 05.02/ GSM 05.02 (phase2) version 4.3.0

/GSM 08.58/ GSM 08.58 (phase2) version 4.2.0

Whenever a reference is made to a function described in another chapter, please refer to the table of contents to find the appropriate chapter.

29.2 Function

By means of the MODE MODIFY procedure /GSM: 08.58:4.2./ BSC orders RBS to change channel mode of an active dedicated channel group.

Supported channel combinations /GSM:05.02:6.4/:

- (i) TCH/F + FACCH/F + SACCH/TF
- (ii) TCH/H(0.1) + FACCH/H(0.1) + SACCH/TH(0.1)
- (viii) TCH/F + FACCH/F + SACCH/M
- (ix) TCH/F + SACCH/M
- (x) TCH/FD + SACCH/MD

RBS actions:

- Interpretation of MODE_MODIFY message from BSC
- Channel Mode Modification

The function is initiated when a MODE_MODIFY message / GSM:08.58:8.4.9/, is received from BSC. Any transition between the following full rate channel modes /GSM:08.58:9.3.6/ is supported:

| | |
|-------------|---|
| TCH/F | Signalling |
| TCH/FS | Full rate speech, GSM speech alg. ver 1 |
| TCH/FS | Full rate speech, GSM speech alg. ver 2 |
| TCH/F9.6 NT | Full rate data 9.6 kbit/s non-transparent |
| TCH/F9.6 | Full rate data 9.6 kbit/s transparent |
| TCH/F4.8 | Full rate data 4.8 kbit/s transparent |
| TCH/F2.4 | Full rate data 2.4 kbit/s transparent |
| TCH/F2.4 | Full rate data 1.2 kbit/s transparent |
| TCH/F2.4 | Full rate data 1200/75 bit/s transparent |
| TCH/F2.4 | Full rate data 600 bit/s transparent |

Any transition between the following full rate, multislot, Channel Modes is supported:

| | |
|-------------|--|
| TCH/F | Signalling, Bi-directional (not allowed on channel combination ix) |
| TCH/FS | Full rate speech, GSM speech alg. ver 1 Bi-directional |
| TCH/FS | Full rate speech, GSM speech alg. ver 2 Bi-directional |
| TCH/F9.6 NT | Full rate data 9.6 kbit/s non-transparent, Bi-directional |
| TCH/F4.8 | Full rate data 4.8 kbit/s transparent, Bi-directional |
| TCH/F2.4 | Full rate data 2.4kbit/s transparent, Bi-directional |
| TCH/F2.4 | Full rate data 1.2 kbit/s transparent, Bi-directional |
| TCH/F2.4 | Full rate data 1200/75 bit/s transparent, Bi-directional |
| TCH/F2.4 | Full rate data 600 bit/s transparent, Bi-directional |
| TCH/FS | Full rate speech, GSM speech alg. ver 1 Uni-directional |
| TCH/FS | Full rate speech, GSM speech alg. ver 2 Uni-directional |
| TCH/F9.6 NT | Full rate data 9.6 kbit/s non-transparent, Uni-directional |
| TCH/F9.6 | Full rate data 9.6 kbit/s transparent, Uni-directional |
| TCH/F4.8 | Full rate data 4.8 kbit/s transparent, Uni-directional |
| TCH/F2.4 | Full rate data 2.4 kbit/s transparent, Uni-directional |
| TCH/F2.4 | Full rate data 1.2 kbit/s transparent, Uni-directional |
| TCH/F2.4 | Full rate data 1200/75 bit/s transparent, Uni-directional |
| TCH/F2.4 | Full rate data 600 bit/s transparent, Uni-directional |

Any transition between the following half rate Channel Modes/
GSM:08.58:4.2/ is supported:

| | |
|----------|---|
| TCH/H | Signalling |
| TCH/HS | Half rate speech |
| TCH/H4.8 | Half rate data 4.8 kbit/s non-transparent |
| TCH/H4.8 | Half rate data 4.8 kbit/s transparent |
| TCH/H2.4 | Half rate data 2.4 kbit/s transparent |
| TCH/H2.4 | Half rate data 1.2 kbit/s transparent |
| TCH/H2.4 | Half rate data 1200/75 kbit/s transparent |
| TCH/H2.4 | Half rate data 600 bit/s transparent |

Mode change between full rate channels, half rate channels and multislot channels is not accepted.

Mode change between secondary channels are supported.

The Mode Modify message has one optional element:

“Encryption information”.

RBS checks the availability of the requested resources and acknowledges the MODE_MODIFY message by sending a MODE_MODIFY_ACKNOWLEDGE message /GSM:08.58:8.4.10./ or a MODE_MODIFY_NEGATIVE_ACKNOWLEDGE message / GSM:08.58:8.4.11./ to the BSC.

The MODE_MODIFY_ACKNOWLEDGE message to BSC is not related to the Air Interface. That is, the acknowledgement will be sent before the actual transmission is started.

If the Mode Modify procedure fails after the MODE_MODIFY_ACKNOWLEDGE message has been sent, a CONNECTION_FAILURE_INDICATION /GSM:08.58:8.4.4/ message is sent to BSC and the channel mode is changed to the mode requested in the MODE_MODIFY message.

If the MODE_MODIFY_NEGATIVE_ACKNOWLEDGE message is sent to the BSC, the channel mode is left unchanged (same as before the MODE_MODIFY message was received).

After the positive acknowledgement of the MODE_MODIFY message, the active service is deactivated and the requested service is activated.

29.3 Operational Conditions

The maximum delay from reception of a MODE_MODIFY command until the command is acknowledged (MODE_MODIFY_ACKNOWLEDGEMENT or MODE_MODIFY_NEGATIVE_ACKNOWLEDGEMENT) is 25 ms.

This page is intentionally left blank

30 Mobile Station Power Control

By means of the "MS Power Control" procedure /GSM:08.58:- 4.8/, BSC gives RBS the power level to be used by MS, on a dedicated resource.

MS power control is employed to minimise the transmit power required by the MS while maintaining the quality of the radio links. By minimising the transmit power levels, interference to co-channel users is reduced.

Functionality supported:

- MS power control, at channel activation
- MS power control, for an active channel

Channel Activation function is not described here.

30.1 References

| | |
|-------------|----------------------------------|
| /GSM 04.04/ | GSM 04.04 (phase2) version 4.0.0 |
| /GSM 05.02/ | GSM 05.02 (phase2) version 4.3.0 |
| /GSM 08.58/ | GSM 08.58 (phase2) version 4.2.0 |

Whenever a reference is made to a function described in another chapter, please refer to the table of contents to find the appropriate chapter.

30.2 Functions

30.2.1 MS Power Control at Channel Activation

Supported channel numbers:

- Bm + ACCH
- Lm + ACCH
- SDCCH/8 + ACCH
- SDCCH/4 + ACCH and TN = 0

Supported channel combinations /GSM:05.02:6.4/:

- (i) TCH/F + FACCH/F + SACCH/TF
- (ii) TCH/H(0.1) + FACCH/H(0.1) + SACCH/TH(0.1)
- (v) FCCH+SCH+BCCH+CCCH+SDCCH/4(0..3)+SACCH/C4(0..3)
- (vii) SDCCH/8(0..7) + SACCH/C8(0..7)
- (viii) TCH/F + FACCH/F + SACCH/M
- (ix) TCH/F + SACCH/M
- (x) TCH/FD + SACCH/MD

RBS actions:

- Storage of MS power level

- Order MS to set the commanded power level

Description

The function is initiated when a CHANNEL_ACTIVATION message / GSM:08.58:8.4.1/ containing MS Power is received from the BSC.

The value of the ordered MS power /GSM:08.58:9.3.13/ is passed transparently to the MS.

RBS stores the MS power level received from BSC and includes it in the L1 header of all downlink SACCH blocks /GSM:04.04:7.1/.

30.2.2 MS Power Control for an Active Channel

Supported channel numbers and Supported channel combinations / GSM:05.02:6.4/, see the section above.

RBS actions:

- Interpretation of the MS_POWER_CONTROL message
- Storage of MS power level
- Order MS to set the commanded power level

Description

The function is initiated when an MS_POWER_CONTROL message / GSM:08.58:8.4.15/ containing MS Power is received from the BSC for an active dedicated channel.

The value of the ordered MS Power /GSM:08.58:9.3.13/ is passed transparently to the MS.

The MS Power parameters /GSM:08.58:9.3.31/ is not supported by the RBS.

RBS stores the MS power level received from BSC and includes it in the L1 header of all downlink SACCH blocks /GSM:04.04:7.1/. It overwrites the MS power value set by any previous "Channel Activation" or "MS Power Control" functions.

30.2.3 MS Power Control at Channel Reactivation

SeeSection 30.2.1 on page 295.

31 Short Message Service

SMS P-P (Short Message Service Point-to-Point) provides a means of sending messages of limited size to and from a mobile.

SMSCB (Short Message Service Cell Broadcast) is a service in which short messages may be broadcast to all mobiles in a cell.

RBS Functionality supported:

- SMS Point-to-point, Mobile Terminated
- SMS Point-to-point, Mobile Originated
- SMS Cell Broadcast

The SMS P-P function is based on the following functions, not described in this specification:

- Link Establishment
- Link Release
- Transparent Message Transfer

31.1 References

/GSM 04.12/ GSM 04.12 (phase2) version 3.2.1

/GSM 05.02/ GSM 05.02 (phase2) version 4.3.0

/GSM 08.58/ GSM 08.58 (phase2) version 4.2.0

Whenever a reference is made to a function described in another chapter, please refer to the table of contents to find the appropriate chapter.

31.2 Functions

31.2.1 SMS Point-to-Point, Mobile Terminated

RBS supports:

- Establishment of a SAPI-3 (Service Access Point Identifier 3) link
- Transparent transmission of SMS messages
- Release of a SAPI-3 link

Supported logical channels /GSM:05.02:3.3.4/:

SDCCH/4 Stand-Alone Dedicated Control Channel/4

SDCCH/8 Stand-Alone Dedicated Control Channel/8

SACCH/TF Slow Associated Control Channel, full rate traffic

SACCH/TH Slow Associated Control Channel, half rate traffic

Supported channel combinations /GSM:05.02:6.4/:

- (i) TCH/F + FACCH/F + SACCH/TF

- (ii) TCH/H(0.1) + FACCH/H(0.1) + SACCH/TH(0.1)
- (v) FCCH+SCH+BCCH+CCCH+SDCCH/4(0..3)+SACCH/C4(0..3)
- (vii) SDCCH/8(0..7) + SACCH/C8(0..7)
- (viii) TCH/F + FACCH/F + SACCH/M

The SMS P-P MT function is initiated when an ESTABLISH REQUEST message for a SAPI-3 link is received from the BSC.

SMS P-P MT messages are transmitted as transparent L3 (Layer 3) messages (in acknowledged mode), on a SAPI-3 link between the network and the MSs.

SAPI-3 link establishment and release is made on request from BSC. The function is terminated when a RELEASE_CONFIRM message is sent to the BSC, as a result of a SAPI-3 link release.

31.2.2 SMS Point-to-Point, Mobile Originated RBS

RBS supports:

- Establishment of a SAPI-3 link
- Transparent transmission of SMS messages
- Release of a SAPI-3 link

See section above for:

- Supported logical channels
- Supported channel combinations

The SMS P-P MO function is initiated when a SABM frame (link layer connection) is received from an MS. SMS P-P MO messages are transmitted as transparent L3-messages (in acknowledged mode), on a SAPI-3 link between the network and the MSs.

SAPI-3 link establishment and release is made on request from MS. The function is terminated when a RELEASE_INDICATION message is sent to the BSC, as a result of a SAPI-3 link release.

31.2.3 SMS Cell Broadcast

This procedure is used by the BSC to request the RBS for transmission of SMS cell broadcast messages on the logical channel CBCH/ GSM:08.58:5.6/.

The BSC handles the queuing and repetition of the SMSCB messages, taking the capacity of CBCH into account.

Supported Logical Channels /GSM:05.02:3.3.5/:

CBCH Cell Broadcast Channel, allocated on SDCCH sub-channel 2

Supported Channel Combinations /GSM:05.02:6.4/:

- (v) FCCH + SCH + BCCH + CCCH + SDCCH/4[0.1,3] + SACCH/C4[0.1,3] + CBCH
- (vii) SDCCH/8[0.1,3..7] + SACCH/C8[0.1,3..7] + CBCH

RBS Actions:

- Interpretation of SMS_BROADCAST_REQUEST messages
- Transmission of SMSCB messages
- Transmission of CBCH Fill-frame

Description

Configuration parameter CBCH Ind must be set to 1, to indicate the usage of SDCCH sub-channel 2, for SMSCB messages.

Transmission of SMSCB messages on channel combination (vii) requires that configuration parameter BS_AG_BLKES_RES is set to a value greater than zero, /GSM:05.02:6.5.4/ /GSM:05.02:3.3.2.3/. The function is initiated when the first (out of four)

SMS_BROADCAST_REQUEST message is received from the BSC.

Four SMS_BROADCAST_REQUEST messages together make a complete SMSCB message. All four blocks must be available before any transmission on the CBCH channel can take place.

Each SMS_BROADCAST_REQUEST message contains a complete frame (including a Message type field = Layer 2 header) /GSM:04.12:3/, to be transmitted on the CBCH channel.

The Message Type field contains a sequence number, used to check the order of arrival. The correct order of arrival is defined as: 0,1,2,3.

The SMSCB messages are transmitted in four consecutive multiframes / GSM:05.02:6.5.4/ during periods when TB = 0, 1, 2 and 3.

CBCH Fill-frames are transmitted on the CBCH channel when TB=0, 1, 2 and 3, and no SMSCB message is available for transmission. Nothing is transmitted for TB = 4, 5, 6 and 7. $TB = (FN \text{ DIV } 51) \text{ MOD } 8$ (where FN = Frame Number).

A CBCH fill-frame consists of:

- 1 octet, Message Type /GSM:04.12:3.3.1/ with Sequence Number = F (hex)
- 22 octets=2B (hex)

31.3 Operational Conditions**31.3.1 SMS MT/MO P-P**

The maximum length of a message can be 140 octets or 160 SMS characters.

31.3.2 SMS Cell Broadcast

The transmission time over the air interface for one SMSCB message (4 blocks, 23 octets each) is:

- $4 * 51 * 120/26 \text{ milliseconds} = 0.941 \text{ seconds.}$

The maximum sending intensity is one message per 1.88 seconds (4 blocks of data and 4 empty frames).RBS provides storage capacity for two complete SMSCB messages.

This page is intentionally left blank

32 Diversity Supervision

The "Diversity Supervision" function supervises the signal strength imbalance between the two diversity channels in an RBS with receiver diversity.

The function is capable of detecting major faults in the radio receiver paths or the receiver antenna system.

32.1 References

/GSM:05.08/ GSM Requirements 05.08 Phase 2 version 4.6.0

Whenever a reference is made to a function described in another chapter, please refer to the table of contents to find the appropriate chapter.

32.2 Concepts

| | |
|-------------------------------|--|
| Measurement Period | The Measurement Period corresponds to the "reporting period" of the radio link measurements as specified in /GSM 05.08/. The Measurement Period is defined only for dedicated channels. Basic channel measurements on dedicated channels, as the signal strength measurements, are made for each Measurement Period |
| Observation Period | The Observation Period defines a time window during which the signal strength relationship between the two diversity channels is observed before any decision regarding a possible disturbance is taken. |
| Channel Utilisation Threshold | The Channel Utilisation Threshold (CUT) is the criterion for an active dedicated channel to be regarded as utilised. It is that the receiver signal strength is above a certain level on at least one of the diversity channels. The Channel Utilisation Threshold is characterised by the required signal strength. |
| Channel Utilisation Ratio | The Channel Utilisation Ratio (CUR) is defined here as the relative rate of utilisation of a dedicated channel or a set of dedicated channels during a certain period of time. The CUR is calculated per observation period. (It is the same for both of the receiver's diversity channels.) |
| Minimum CUR | The Minimum Channel Utilisation Ratio is the lowest CUR at which the receiver diversity is supervised. The minimum CUR is applied to the entire transceiver |

| | |
|---------------------------|--|
| Signal Strength Imbalance | The SSI (Signal Strength Imbalance) is defined here as the mean difference (in decibels) between the receiver's two diversity channels. The SSI is calculated per observation period |
| Disturbance Threshold | The Disturbance Threshold defines the limit for the signal strength imbalance, at which it is classified as abnormal and is regarded as a disturbance |

32.3 Function

The signal strengths of the two diversity channels are measured and compared after the signals have passed through radio receiver equipment. The diversity supervision is applied to dedicated channels only.

The following actions are carried out separately for each TS:

- The signal strengths are measured separately for the two diversity channels during all measurement periods for all dedicated channel connections which qualify for the channel utilisation threshold criterion

In order to avoid degradation from possible DTX (Discontinuous Transmission) employed by MS, the signal strength measurements on TCH are restricted to the subset of 4 SACCH frames and 8 SID (Silence Descriptor) TDMA frames as defined in /GSM 05.08/.

- The CUR_i is calculated for the TS during each observation period
- The SSI_i value is calculated for the TS during each observation period

The CUR_i and the SSI_i values from all TSs are then evaluated together. The corresponding transceiver gross measures are calculated for each observation period:

$$SSI = i \sum (SSI_i * CUR_i) / i \sum CUR_i ; i = 0..7$$

$$CUR = i \sum CUR_i / i \sum 1 ; i = 0..7$$

A disturbance is assumed to exist when both of the following criteria are fulfilled:

- The gross CUR exceeds the minimum channel utilisation ratio
- The value of the gross SSI exceeds the disturbance threshold

A fault is reported after filtering of the detected disturbances. The fault condition ceases only after a leaky bucket filter is emptied by a number of valid observation periods without disturbances.

Only those observation periods where the gross CUR exceeds the minimum channel utilisation ratio are taken into account in the filtering process. This means that a fault condition is only raised or ceased during valid observation periods.

32.4 Operational Conditions

The diversity supervision is characterised by a number of parameters which are implemented as software constants. The parameter values are selected so that the risk of false disturbances during normal operation is negligible:

Table 110 Preliminary diversity supervision parameters

| | |
|-----------------------------------|-----------|
| Observation period | 5 minutes |
| Channel utilisation threshold | -96 dBm |
| Minimum channel utilisation ratio | 5 % |
| Disturbance threshold | 12 dB |

The disturbance filter characteristics will give the time to alarm. If 100% of the observation periods causes a disturbance, the time to alarm will be 50 minutes. If the disturbance ratio is less than 50% no alarm will be raised.

If 100% of the observation periods indicates no disturbance, the alarm will be terminated after 100 minutes. If the disturbance ratio is more than 15%, the alarm will not be terminated.

This page is intentionally left blank

33 Synchronization

The purpose of this function is to synchronize an RBS internally. The function is needed to achieve air timeslot synchronization, according to /GSM:05.10/ and /JTC PCS:7/.

The transition between different states and functions can be seen in the figure below.

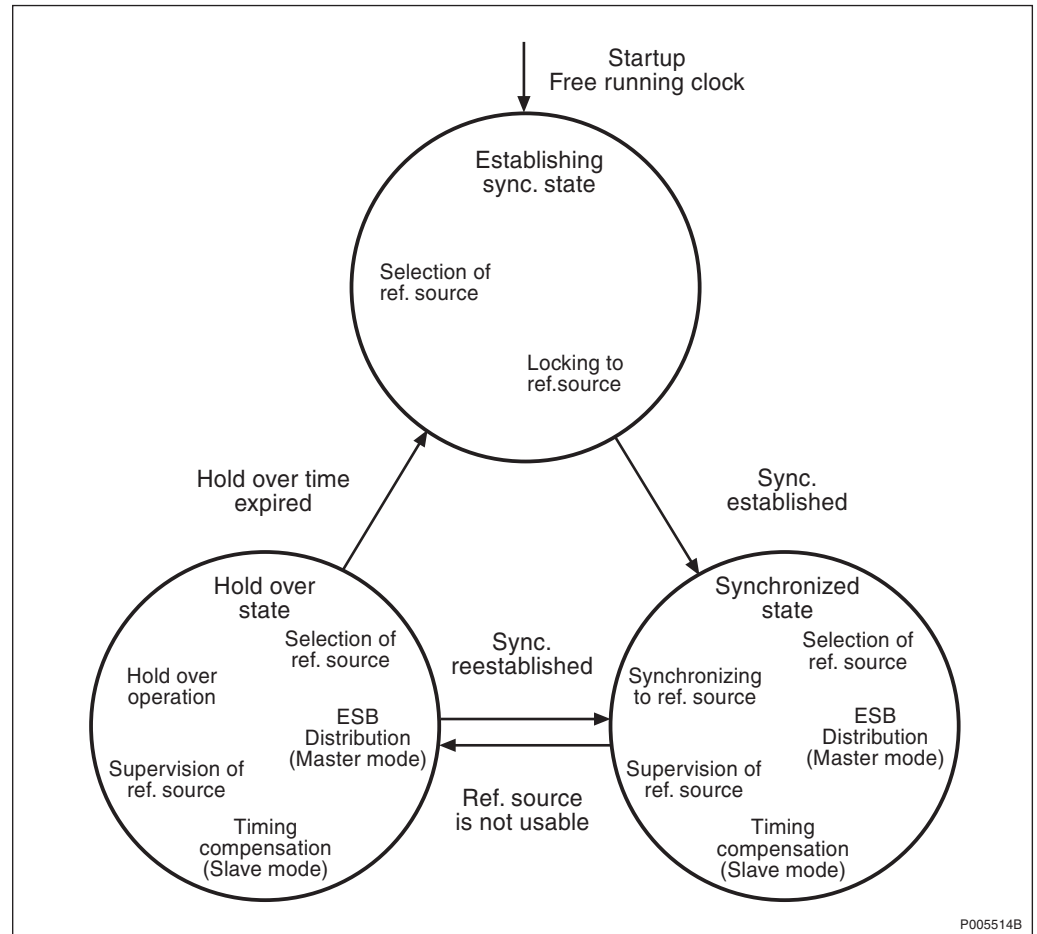

Figure 88 Synchronization function states

Short-term stability of the timing is achieved by the RBS itself. The long-term stability of the RBS will rely on an external or an optional synchronization reference.

The external synchronization reference is taken from one of the two PCM interfaces in the transport network interface or from another RBS via the External Synchronization Bus, ESB.

The optional synchronization reference is taken from an optional synchronization function in the RBS.

The three possible sources for synchronization are handled in the same way by the synchronization function. The BSC is able to request that either the transport network, the optional synchronization function or another RBS to be used for synchronization.

The synchronization function can have three different modes:

- Stand-alone

In this mode the RBS uses an incoming PCM-reference or the optional reference as synchronization reference. The RBS is not synchronized with any other RBS.

- Master

In this mode the RBS uses an incoming PCM-reference or the optional reference as synchronization reference. The generated timing is also distributed to other RBSes in the RBS cluster via the ESB.

- Slave

In this mode the RBS uses another RBS as synchronization reference. The RBS is synchronized with another RBS, configured as Master, in the RBS cluster via the ESB.

The mode is set by BSC. Default mode is internally set to Stand-alone.

The Master and Slave modes are used to synchronize RBSes within an RBS cluster with each other. The different RBSes within the RBS cluster work together according to the master and slave logic, see the figure below. One of the RBSes is selected as master by the BSC, and the other RBSes in the RBS cluster are configured as slaves. The master RBS synchronizes towards the PCM-reference or the optional reference. The slave RBS(es) synchronizes towards the master RBS via the ESB.

Reference source (PCM-reference or optional reference)

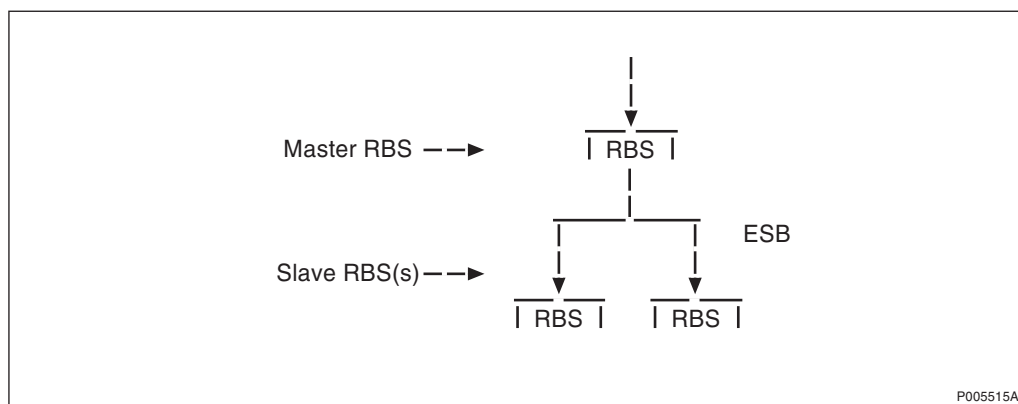

Figure 89 Master slave logic of RBSes

33.1 References

/GSM 05.10/

GSM TS 05.10 revision 4.3.0

/JTC PCS/

JTC(AIR) 940904–231R4 Technical Specification of PCS 1900 by the PCS 1900 Joint Technical Committee

/G.823/

CCITT G.823, White Book

Whenever a reference is made to a function described in another chapter, please refer to the table of contents to find the appropriate chapter.

33.2 Concepts

| | |
|------------------------------------|---|
| Locking | The process of acquiring a phase lock to the reference |
| Synchronizing | The process of maintaining a phase lock to the reference |
| Internal Source | An internal short-term stable oscillator |
| Optional Reference | An optional frequency reference source built into the RBS |
| PCM-reference | A frequency reference extracted from the PCM-network |
| External Synchronization Bus (ESB) | A bus for distribution of synchronization information between RBSes in an RBS cluster |
| RBS cluster | Two or more RBSes connected together via an External Synchronization Bus |

33.3 Synchronizing to the Reference Source

Purpose

The short-term stable oscillator built into the RBS needs to have a long-term stable synchronization reference. The function provides the RBS with the long-term synchronization source.

Precondition and Initiation

The function is initiated by two separate events:

- Synchronization established
- When synchronization is re-established after hold-over operation

Description

The RBS has its own short-term stable oscillator; this internal source is locked to the reference source. The generated frequency is used for both RF frequency and for clocking of the timebase counters (see / GSM:05.10:3/ and /JTC PCS:7-1/). The same source is used for all carriers.

Termination

The function is terminated by three separate events:

1. The executive reference source is considered faulty by the supervision function.
2. The control values of the RBS short-term frequency source of the TU are persistently at limit values.
3. Reconfiguration of TF mode to Slave.

Note: It is not possible to change TF mode to Slave in enabled state.

Operational Conditions

Synchronization is reached as noted below from function initiation.

| | | |
|---|--|--|
| Cold start | Transmission network or other RBS as source | 5 minutes |
| | Optional frequency source For both network and optional | 10 minutes |
| RBS is synchronized and Reset command received on ABIS | Transmission network, Optional frequency source or other RBS as source | 10 seconds |
| RBS is synchronized and Start command after Function Change is received | Transmission network, Optional frequency source or other RBS as source | 30 seconds |
| Warm start | Transmission network, Optional frequency source or other RBS as source | 90 s when there is not jitter in the synch. source |

33.4 Selection of the Reference Source

Purpose

The purpose is to increase the system's air time; that is to say, the possibility to use different synchronization sources decreases the possibility for system failure caused by lack of a synchronization source.

Precondition and Initiation

The PCM reference must be marked available in order to be considered for selection. The function is initiated by one of the following events:

- Start-up of RBS
- "Hold-over expired time" is reached (see Hold-over Operation)
- Synchronization reference source is re-established in Hold-over state
- At TF (Timing Function) configuration
- When locking to the reference source is terminated without successful locking

Description

The function decides which reference source is to be used for synchronization; that is to say, PCM interface, optional reference or other RBS. The choice depends on the type of equipment installed and parameters received at TF configuration according to the table below. Units equipped with an optional reference source will always use this

option as default. By a command over A-bis it is possible to change between the optional reference source (if installed) and the PCM interface.

Table 111

| TF Config. Parameters | | Selected Synch. Source Type | |
|------------------------|-----------------------|-----------------------------|-----------------------|
| TF Mode | TF Synch. Source Type | Optional Synch. HW | No Optional Synch. HW |
| Not defined | Not defined | Optional | PCM |
| Master/ Stand-alone | Not defined | Optional | PCM |
| | PCM | PCM | PCM |
| | Internal | Optional | PCM ¹⁾ |
| Slave | Does not care | Other RBS | Other RBS |

¹⁾ Rejected by the Capability Conformance Check function.

If the transport network is used for synchronization, the executive reference is taken from PCM interface A at start-up of the RBS on condition that interface A is available for synchronization and is fault free. Otherwise PCM interface B is selected if it is available and fault free.

The executive reference may change from one of the PCM interfaces to the other when signal on the executive reference is lost (AIS, LOF or LOS condition on the selected executive reference, see function Supervision of Reference Source), provided that a signal is detected at the other interface and that the other reference is marked "available".

The function is terminated when a new executive reference source has been selected or if the executive PCM reference regains its synchronization signal before a reselection is attempted or if a reselection is made to another synchronization source. There is no momentary change in phase or frequency of the RBS caused by reselection of synchronization source.

33.5 Hold-Over Operation

Purpose

If the reference signal is considered not to be usable, the RBS cannot use its values for regulation of the internal oscillator. The Hold-over operation function keeps the RBS synchronized for a period of time even though the reference signal is not present.

Precondition and Initiation

The function is initiated when the reference signal is not usable.

Description

The function when initiated freezes the control panel parameters for the internal oscillator at the present value, meaning that the oscillator frequency is kept constant except for ageing and temperature drift. The

RBS will still be considered as synchronized and the supervision of the reference source will continue. After 5 minutes lack of reference signal known as "Hold-over entered time" a fault is sent to the BSC reporting the lack of reference source. This fault actually implies for an ITU-T G.703 2048 kbit/s system that the reference on both PCM-A and PCM-B is not usable. If the RBS has not regained its synchronization either by re-establishment or reselection within 60 minutes (when TF mode is master and stand-alone) and within 15 minutes (when TF mode is slave), it is reported to the BSC which orders the RBS to disable all radio transmission. This maximum time for the internal oscillator to guarantee synchronization quality is known as "Hold-over expired time". The function is terminated when the reference source is considered as usable or after "Hold-over expired time".

33.6 Supervision of Reference Source

Purpose

The function should decide if the reference source is to be considered as usable or not. This is done by supervision of the synchronization source as well as the quality of the synchronization signal.

Precondition and Initiation

The function is initiated when synchronization to the reference source is established.

Description

Depending on if the PCM interface or the Optional reference source or another RBS is used as a reference, the following criteria are used for evaluation of the reference source.

PCM interface as reference:

- LOS (Loss Of Signal), LOF (Loss Of Frame alignment) or AIS (Alarm Indication Signal) detected by physical interface.
- Illegal high jitter and wander characteristics. The limit is specified in /G.823/.
- Illegal high relative frequency deviation. The limit is 0.1 ppm.

Optional reference source:

- Failure of the optional reference source.
- Illegal high jitter and wander characteristics. The limit is specified in /G.823/.
- Illegal high relative frequency deviation. The limit is 0.1 ppm.

Other RBS as reference:

- Interruption.
- Correct and continuous frame number.
- Illegal high wander characteristics. The limit is specified in /G.823/.

- Illegal high relative frequency deviation. The limit is 0.1 ppm.

The outcome of this continuous supervision of the reference is either that the reference is usable or not. The function terminates when "Hold-over expired time" ends in "Hold-over state".

33.7 Locking to the Reference Source

Purpose

The function supervises the locking process and limits the time for locking to the reference source.

Precondition and Initiation

The function is initiated when a locking attempt to a reference source is made.

Description

The function checks that the control values for the internal source have stabilised to within a range not including the highest and lowest values, with a margin. Depending if the PCM interface or the Optional reference source or another RBS is used as a reference, the following criteria are used for evaluation of the locking process.

Locking to the PCM interface:

- PCM-reference presence (detected by physical interface)
- Time, a time-out set at initiation
- The value of the oscillator control signal

Locking to the optional reference:

- Non-failure status of the optional sync. function
- Time, a time-out set at initiation
- The value of the oscillator control signal

Locking to other RBS:

- ESB synchronization presence
- Time; a time-out set at initiation
- The value of the oscillator control signal

The time-out, which is 6 minutes, is in both cases used to disqualify a locking attempt that takes too long. A fault is sent to the BSC at time-out, but the internal source will still try to lock an available reference. Limited functionality is reached within 4 minutes from function initiation. Calls can be established but performance criteria are not fulfilled, that is to say, the risk of dropped calls is higher. The function terminates when synchronization is established.

33.8 FN-Offset

Purpose

The purpose is to improve handover performance. If one RBS is configured for several cells and handover is done between two cells controlled by the same RBS, the handover execution time will be longer if the two cells are synchronized together.

Precondition and Initiation

The function is initiated by a request from the BSC.

Description

The FN (Frame Number) offset function makes it possible for a TRU at a site to use a defined offset from the TDMA number distributed from the central timing of the RBS. The offset value is added to the distributed TDMA frame number.

The offset is configurable from the BSC per timeslot, the condition is that all timeslots must be disabled. Configuration of one timeslot will reconfigure all the others. The configuration is carried out by the Functionality Administration function.

33.9 ESB Distribution

Purpose

This function defines that the timing information is distributed on the ESB interface, when TF mode is defined or changed to master.

Precondition and Initiation

The function is initiated by two separate events:

- At TF enable when TF mode is defined to master
- At TF configuration in enabled state when TF mode is changed to master

Description

The timing information is distributed on the ESB interface and the ESB measurement loop is closed. The function is terminated when TF state is changed from enabled, or TF mode is changed from master.

33.10 Timing Compensation

Purpose

This function displaces the internal timing bus towards the ESB with the TF compensation value received at TF configuration.

Precondition and Initiation

At TF configuration when TF mode is defined to Slave.

Description

The timing difference between different carriers within a cell shall be less than 1/4 bit in the air (920 ns). To fulfil this requirement the following delays must be compensated for:

- the distribution delay on the external synchronization bus
- the transmitter chain delay (delays in transmitter, combiner, feeder and antenna)

The BSC/OSS operator defines one RBS in the RBS cluster to master and the others to slave(s). For each slave the OMT operator also calculates and defines a TF compensation value. The TF compensation value is forwarded to the slave(s) at TF configuration.

The operator uses the following formula to calculate the TF compensation value, TF_{cv} , for each slave:

$$TF_{cv} = \text{master } t_{txd} - \text{slave } t_{txd} - t_{esb}$$

t_{esb} is the distribution delay on the external synchronization bus between the master and the slave. There can be different delays for each slave. Elements that affect this delay are cable length(s), cable type, cabinet type and the RBS-cluster topology.

t_{txd} is the transmitter chain delay (delays in transmitter, combiner, feeder and antenna). There can be different delays for each RBS.

A positive value on the TF_{cv} indicates that the internal timing bus is delayed relative to the ESB. A negative value indicates that the internal timing bus is advanced relative to the ESB.

The RBS also adopts the frame number from the ESB and distributes it on the internal timing bus. The function terminates when TF mode is changed from Slave.

This page is intentionally left blank

34 Radio Reception

Radio reception defines the function to receive an RF signal from the air interface and restore the bit stream. Diversity is used to improve the sensitivity on the receiver. It is achieved by having two antennas, and by that means take advantage of two or more receiver paths.

34.1 References

For GSM 900 and GSM 1800:

/GSM 05.04/ GSM Requirements 05.04 Phase 2

/GSM 05.05/ GSM Requirements 05.05 Phase 2

For GSM 1900:

The references PCS: 4-6 are chapters in the document: Volume 1, PCS 1900 Physical Layer 1 Specification marked: JTC(AIR)94.08.01-231R3

/PCS 4/ Modulation

/PCS 5/ Radio Transmission and Reception

/PCS 6/ Radio Subsystem Link Control

34.2 Radio Reception

Purpose

To receive an RF signal and restore the bit stream that constitutes a burst.

Precondition and initiation

The ATSR must be in traffic. The reception initiates when the ATSR is taken into traffic.

Description

The RBS receives an RF signal from the MS on the air interface. First the signal is filtered in order to isolate the targeted MS signal from other transmission. Then the signal is amplified and finally demodulated. In the demodulation phase the bit stream that constitutes a burst is restored.

The GSM 900 specification of Receiver characteristics is found in /GSM 05.04/ and /GSM 05.05/.

The GSM 1900 specification of Receiver characteristics is found in /PCS 4/, /PCS 5/ and /PCS 6/.

34.3 Diversity

Purpose

To improve sensitivity on received signal.

Precondition and initiation

The Air Time Slot Resources (ATSR) must be configured for diversity. The diversity initiates when the ATSR is taken into traffic.

Description

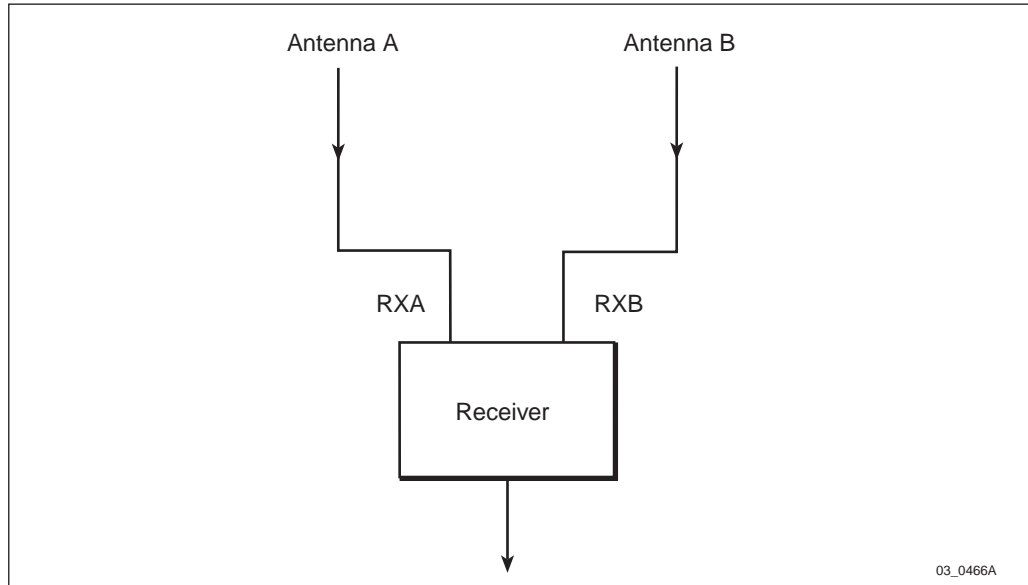

Figure 90 Diversity

One way to improve your performance on received signal is by using diversity. This can be achieved by using two reception channels that are independently influenced by fading. Both of the two insinals from the antennas are combined in the receiver. The receiver uses the weaker signal together with the stronger signal, with a factor proportional to SNR (Signal to Noise Ratio) on each antenna.

35 Radio Transmission

Radio transmission denotes the function to "Generate a Radio Frequency (RF) signal".

35.1 References

Whenever a reference is made to a function described in another document, please refer to the relevant Function Specification List to find the appropriate document.

35.1.1 For GSM 900 and GSM 1800:

| | |
|-------------|--------------------------------|
| /GSM:05.02/ | GSM Requirements 05.02 Phase |
| /GSM:05.04/ | GSM Requirements 05.04 Phase |
| /GSM:05.05/ | GSM Requirements 05.05 Phase |
| /GSM:05.08/ | GSM Requirements 05.08 Phase 2 |
| /GSM:05.10/ | GSM Requirements 05.10 Phase 2 |

35.1.2 For GSM 1900:

| | |
|-------------|--------------------------------|
| /GSM:05.02/ | GSM Requirements 05.02 Phase 2 |
|-------------|--------------------------------|

The references /PCS:1/-/PCS:8/ are chapters in the document: Volume 1, PCS 1900 Physical Layer 1 Specification;

The specification is labelled: JTC(AIR)94.08.01-231R3

| | |
|---------|--|
| /PCS:1/ | Physical Layer Overview |
| /PCS:2/ | Multiplexing and Multiple Access on the Radio Path |
| /PCS:3/ | Forward Error Protection Coding and Interleaving |
| /PCS:4/ | Modulation |
| /PCS:5/ | Radio Transmission and Reception |
| /PCS:6/ | Radio Subsystem Link Control |
| /PCS:7/ | Synchronization |
| /PCS:8/ | Change History |

References in the text may have a section number added. For example / ref:5.3.5/ refers to chapter 5, section 3.5.

35.2 Concepts

Base Transceiver Station (BTS), unit operating on a set of radio frequencies in one cell.

Radio Base Station (RBS), all equipment forming an Ericsson base station, may comprise several BTSs.

Combining System and Filtering, is the interface between transmitters and the antenna system. The functionality is:

- Antenna system supervision support
- RF filtering
- Duplex filtering

The TX reference point is defined as the point where the TX antenna signal crosses the RBS border, i.e. the connector for the antenna feeder.

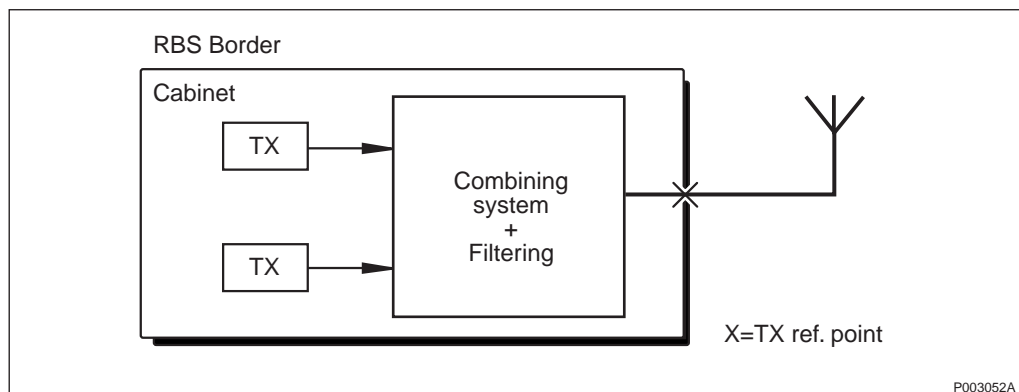

Figure 91 TX reference point

When the RBS is configured with integral antenna the TX reference point is the cabinet output RF connector.

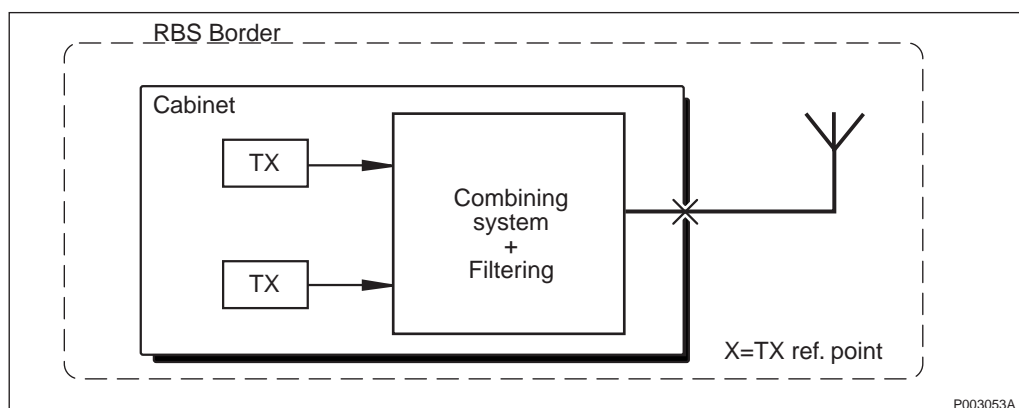

Figure 92 TX reference point with integral antenna

35.3 Functions

35.3.1 Radio Transmission

Radio transmission denotes the function to "Generate an RF signal" from the bit stream that constitutes a burst.

The transmitter uses the modulation format specified in /GSM:05.04/ for GSM 900 and GSM 1800, and /PCS:4/ for GSM 1900.

The RF transmission characteristics are in compliance with requirements in /GSM:05.05/ for GSM 900 and GSM 1800, and /PCS:5/ for GSM 1900.

The synchronization of the RF transmission is in compliance with requirements in /GSM:05.10/ for GSM 900 and GSM 1800, and /PCS:7/ for GSM 1900.

35.3.2 BCCH Carrier Filling

The output power for a transmitter sending the BCCH frequency is constant and equal to the nominal output power, except for the power ramping between bursts, see /GSM 05.08:7.1/ for GSM 900 and GSM 1800 and /PCS:6.5.1/ for GSM 1900.

During idle timeslots dummy bursts are transmitted, the dummy burst is defined in /GSM:05.02:5.2.6/.

35.3.3 Transmitter Filling

The RBS can be configured for transmitter filling. All transmitters serving a cell are then configured with a filling level which transmits dummy bursts in the idle timeslots.

Transmitter filling is not configurable for synthesized frequency hopping transmitters.

Transmitter filling is not configurable for transmitters configured for DTX.

Transmitters configured for BCCH carrier are not affected by the filling level.

35.3.4 SW Power Boost

In order to improve the downlink performance, the BTS can be configured for TX diversity. Two transmitters connected to different antennas are then transmitting with maximum power on the same frequency. One of the transmitters has its bursts forwarded in time two bits compared to the other. The MS receiver signal processing will then contribute to a downlink performance gain of some 3 dB.

SW Power Boost is initiated when the master transmitter is configured on A-bis to a nominal power value 2 dB higher than the maximum nominal power defined for the TX, and no Operation & Maintenance Link is established to the slave transmitter in the radio cabinet.

Faults from one of the two TX instances will result in that a class 2 fault, TX Diversity fault, is reported from the TX via fault reports over A-bis.

35.4 Operational Conditions

35.4.1 Capabilities

The transmitter can control the output power as defined by the Base Station Power Control function.

The transmitter is capable of frequency hopping as defined by the Frequency Hopping function.

35.4.2 Frequency Bands

Transmitters for the GSM band are capable to operate in the extended GSM frequency band, 925 - 960 MHz. The combining system supports the primary GSM 900 band, 935 - 960 MHz, see /GSM:05.05:2/.

Transmitters for the GSM 1800 band operates in the 1800 frequency band, 1805-1880 MHz, see /GSM:05.05:2/.

Transmitters for the GSM 1900 band operates in the 1900 frequency band, 1930-1990 MHz, see /PCS:5.1/.

35.4.3 Nominal Power

The nominal power is the maximum output power the transmitter is allowed to use. Nominal power is defined as the power level at the output of the transmitter which in the Micro Building System corresponds to the Tx ref point. The nominal power is set at configuration. It is possible to set 7 values in 2 dB steps with accuracy according to /GSM:05.05:4.1.2/ for GSM 900 and GSM 1800 and /PCS:3.3.3.1/ for GSM 1900.

35.4.4 Output Power

The output power is measured at the TX reference point, see Section 35.2 Concepts on page 317.

The output power is configuration dependent and is described in chapter Radio Configurations, RBS 2000 Micro.

36 Frequency Allocation Support

The FAS function measures the interference level on a number of frequencies, specified by the operator. The measurements are performed on idle channels or idle burst positions.

The TRXC:s execute the FAS function independently of each other (however all TRXC:s don't have to be used). Thus it is here described only how the FAS function works on one TRXC.

FAS measurements can start when the TRXC has been configured with a list of FAS frequencies. Measurements are performed during one or several FAS measurement periods.

Each FAS measurement period is started and stopped by Abis O&M messages. During the FAS measurement period the TRXC shall handle the measurement of the signal levels, on all specified frequencies, once every 15:th second and accumulate the result in one histogram for each frequency.

The result of the measurements is reported on Abis O&M interface on request as calculated median and percentile values for each frequency. The number of times each frequency has been measured on is also reported.

36.1 References

/GSM:05.05/

36.2 Concepts

Percentile value: The proportion of samples in a distribution.

An example: The 90 percentile value for a distribution is the value for which 90 percent of the samples have a value equal to or less than the percentile value.

36.3 Functions

36.3.1 FAS configuration

A Frequency List is received on Abis O&M interface containing maximum 150 frequencies to measure on. The frequencies are coded in a way that can be interpreted as ARFCN:s with a value ranging from 0 until 1023. This value range is accepted (The BTS can however only measure on frequencies for which it has capability). The relation between frequencies and ARFCN:s is specified in /GSM:05.5:1.1/.

The FAS support capability and the number of frequencies transferred are checked.

All eventually on-going measurements are stopped.

Measurement result are cleared.

36.3.2 Start measurement

FAS measurement will be started by O&M message. Old measurement results are Optionally cleared.

36.3.3 Stop measurement

FAS measurement will be stopped either by directed O&M message, or by receiving a new configuration.

36.3.4 FAS measurement

The FAS measurements are performed according to the following:

4. A FAS measurement is done every 15:th second. During that FAS measurement interval the signal strength of each frequency in the frequency list is measured once.
5. During the first 10 seconds of the FAS measurement interval, only idle channels will be measured on, then all available resources are used.
6. If the configuration includes frequencies, for which the TRXC lacks capability to measure on, they are neglected.
7. The measurements are done on idle traffic channels, TCH/F and TCH/H , and on the idle positions in active TCH/F.
8. Frequency hopping is supported, but limited to a maximum of 63 frequencies. Measurements on frequencies belonging to the own TRXC only take place when reception is scheduled for these frequencies (On idle bursts).
9. Measurements are started on a, from one FAS measurement interval to another, sliding position in the FAS frequency list (To avoid that some frequencies may be underrepresented if there isn't always time to measure on them all).
10. The measurements are as equally distributed as possible over all available time slots
11. The measurements are as equally distributed as possible in the multiframe structure, except for active channels where the positions are fixed.
12. The signal strength of each frequency is measured during one burst, in the same way and with the same resolution as in active channel measurement. Not more than four bursts are used for FAS measurements on one time slot during one SACCH measurement period.
13. The result of the measurements are stored in a histogram consisting of 64 counters for each frequency, one counter for each signal level. The number of times a specific signal level has been measured is accumulated in the corresponding counter.

36.3.5 Measurement reporting

Measurements are reported on request by O&M messages.

The TRXC will, for each frequency measured upon, calculate the median value, the percentile value according to the percentile parameter and the number of measurements done on the frequency.

The result of the calculations sent on Abis O&M link in "FM Reports". If a frequency has not been measured upon, i.e. if a number of

measurements equals zero, the median and percentile signal strength values are reported as zero.

36.4 Operational Conditions

At least one timeslot on TCH must be enabled. Measurements can only be performed on enabled timeslots configured as TCH/F or TCH/H. The RX must also be enabled.

This page is intentionally left blank

37 Restart and Recovery

The restart and recovery function allows the RBS or a specific Replaceable Unit, RU, (see CONCEPTS below) to be started or restarted in a controlled manner. Restart occurs with installation, repair or reset. The restart and recovery function is used with:

- power on
- spontaneous reset (watchdog, software fault, memory fault)
- reset button
- BSC ordered reset

The restart and recovery function determines whether a unit is capable of being brought into operation and, if needed, prepares the unit for operation. If the unit cannot be brought into operation then the restart and recovery function identifies the reason for the operator using the base stations visual indicators.

37.1 References

If a reference is made to a function described in another chapter please refer to the table of contents to locate the relevant information.

37.2 Concepts

| | |
|------------|--|
| RU | Replaceable Unit A RU is the smallest unit that can be handled on site or in a repair centre and about which information can be retrieved via OMT or BSC. |
| Main RU | Main Replaceable Unit A main replaceable unit contains one or more processors, to which software can be downloaded from the BSC. A Main RU is classed either as CMRU or DMRU, see below. |
| Sub RU | Sub Replaceable Unit A Sub RU is always connected to a superior Main RU. This connection is used for the retrieval of equipment information. A Sub RU does not normally have a processor. A RU with a processor that is not loadable is also classed as a Sub RU. |
| Passive RU | Passive Replaceable Unit A Passive RU has a very low level of intelligence and is independent of the processor system, e.g. it has no connection for O&M communication. In the RBS 2000 for example the cables are Passive |

| | |
|------|--|
| CMRU | Central Main Replaceable Unit A RBS has one CMRU. |
| DMRU | Distributed Main Replaceable Unit A Main RU is distributed if it is subordinated to the CMRU. |

37.3 Function

37.3.1 Purpose

The entire RBS is brought into operation in a controlled manner. The sequence of events is given below.

37.3.2 Description

The sequence of actions initiated is summarized below:

- 1 start CMRU-processor
- 2 start DMRU-processor
- 3 start Sub RU-processor (if any)
- 4 start CMRU basic functions
- 5 start DMRU basic functions
- 6 start Sub RU basic functions
- 7 conditional RBS DB(Data base)load
- 8 read parameters for OM bus
- 9 define OM address
- 10 link establish functions for Sub RUs connected to DMRU
- 11 link establish functions for Sub RUs connected to CMRU
- 12 update RBS database for Sub RUs connected to CMRU
- 13 link establish functions for all expected DMRUs
- 14 update RBS database for all expected DMRUs
- 15 update RBS database for Sub RUs connected to DMRU
- 16 wait for expected Passive RUs
- 17 internal configuration
- 18 check RBS operational ability
- 19 set fault indicator on all DMRUs with faults
- 20 set operation indicator on all DMRUs with no faults
- 21 set fault indicator on all Sub RUs with faults
- 22 set fault indicator on all DMRUs with faults
- 23 bring CMRU into remote operation

24 bring DMRU into remote operation

Start processor:

- If the checksum for the updated application software is correct, the updated application is chosen as application software.
- If the RU is a DMRU without non volatile memory, the DMRU must retrieve software from the CMRU.
- If database parameters are not useable, are inaccessible or out of range, default values are used instead.

Termination of start processor:

Terminated when the updated application software has started correctly, or with a new reset. If there are problems in starting updated application software, then the base application is chosen as application software.

37.4 Operational Conditions

37.4.1 Operation and Maintenance

Maintenance functions related to restart and recovery are described in the chapter "Operation and Maintenance Terminal". The visual indicators relevant to restart and recovery are described in the chapter "Operation and Maintenance Support Functions". All of the visual indicators associated with a RU are temporarily turned on for a minimum of 2 seconds during the initial restart of that RU. This allows visual identification of any faulty indicators.

37.4.2 Capabilities

The start time is defined as the time elapsed from when the power is turned on (after having been off), or from the reception of reset (reset button pushed or BSC reset order received) to when the RBS is ready to be taken into remote mode. Depending on the reason for restart, certain actions must be taken during start up, which results in various start-up times. Restart time after BSC ordered reset is less than 8 seconds if all RUs are preloaded with software with correct revision and a correct RBS DB is installed. For all other restart cases with a heated oscillator, restart time of the whole RBS is about half a minute. For the restart case with a cold oscillator (power on), restart time of the whole RBS is about 5 minutes. For information of the temperature's influence on start up time and the delay caused by the environment control unit, see the chapter "Radio Configuration, RBS 2000 Macro".

This page is intentionally left blank

38 Function Change

The purpose of "Function Change" is to facilitate the reload, change or upgrade of the RBS software and the subsequent activation of that software. The software is downloaded from the BSC to the RBS via the A-bis interface.

Function change incorporates the following features:

- Rapid initial start
 - Software preloaded in the non-volatile memory of the RBS during manufacture; permits rapid initial start.
- Rapid restart
 - At restart of an RBS following a power failure, the software does not have to be downloaded via the A-bis interface to the RBS. This is because of the non-volatile memory of the RBS.
- Minimised software download time
 - Software is distributed internally within the RBS. Only one copy of the software is downloaded to each RBS, minimising the time required for software download.
- Software download while in traffic
 - The RBS can perform download of software without affecting normal operation. Traffic is affected only when switching over to the downloaded software.

38.1 Concepts

| | |
|---------------|---|
| File Package | A set of individual software files which together constitute a revision of the software required by an entire RBS or by parts of the RBS |
| File Revision | The file revision identifies a specific software file. This includes the type of Main RU the software is intended for execution on as well as the software revision |
| Software file | The software necessary for a class of Main RU and its loadable Sub-RUs. A software file contains application software. |
| CMRU | Central Main Replaceable Unit. An RBS has exactly one CMRU. In the RBS 2000 hardware architecture, the DXU is the CMRU |
| DMRU | Distributed Main Replaceable Unit. A Main RU is said to be distributed if it is subordinated to the CMRU. |

| | |
|---------|---|
| Main RU | Contains one or more processors, to which software can be downloaded from the BSC. A Main RU is either central or distributed, see above. A Main RU may or may not have a direct signalling link to the BSC. |
| RU | Replaceable Unit. An RU is the smallest unit that can be handled on site or in a repair center and of which information can be retrieved via OMT or BSC. |
| Sub-RU | A Sub-RU is always connected to a superior Main RU. This connection is used for retrieval of equipment information. A Sub-RU normally does not have a processor. Note that an RU with a processor that is not loadable, is classified as a Sub-RU. In the RBS 2000 hardware architecture, for example the CDUs are Sub-RUs. |

38.2 Functions

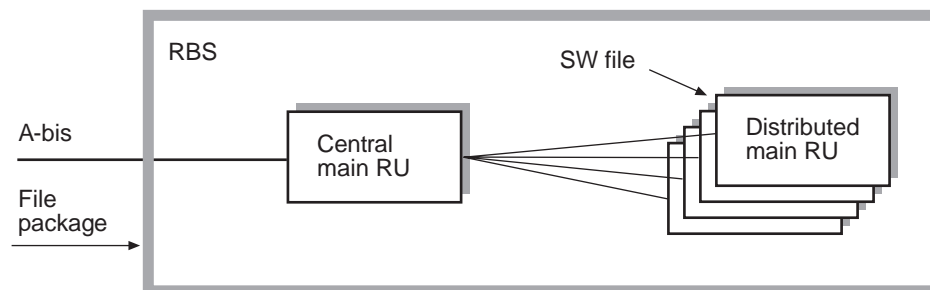

01_0285A

Figure 93 Overview of function change

38.2.1 Software Storage

Every Main RU is equipped with both volatile and non-volatile memory.

Application software, either downloaded via the A-bis interface, transferred internally, or installed during manufacture, is stored semi-permanently in the non-volatile memory.

Before execution, the software is copied from the non-volatile memory into the volatile memory, where it is executed. This arrangement permits the RBS to operate normally, i.e. executing one version of software while loading a new version of software as a background activity.

One area of the non-volatile memory contains the base application software. The base application software can only be updated by function change if the normal application software is valid, thus there is always one application software available. If the normal application is corrupt (or unavailable), the base application software is automatically selected instead.

38.2.2 Software File Relation

Each Main RU visible via the A-bis interface is offered every software file within the appropriate file package. The file revision of the offered software file is compared with that of the software files already held in non-volatile memory in order to determine whether download is necessary or not. Download is carried out only when the file offered has a different revision than the one held in RBS memory.

As an alternative to the above, unconditional download is also supported. In this case, there are no conditions on File Revision etc. for the download.

38.2.3 Software File Download

The CMRU accepts the download of software files intended for all Main RUs in the RBS.

A DMRU never accepts direct download of software files via A-bis, since this must be done via the CMRU.

This arrangement means that only the files actually needed by each Main RU are downloaded. Each individual file is downloaded only once, thus minimising the software download time required. Note that this is an improvement compared to the general A-bis concept; downloading a software file several times, once for each Main RU needing it.

Loading software to a Main RU is allowed in any state, even while operational.

The transfer of a software file is initiated and performed via the A-bis interface. The CMRU stores the transferred software file in non-volatile memory.

During software download to the central Main RU, appropriate software files are transferred internally to the distributed Main RU's.

Only the software files, appropriate to a specific Distributed Main RU, which are not already loaded on that RU are transferred. The software files transferred are stored directly in the non volatile memory of a Distributed Main RU.

38.2.4 Start Required

On completion of the internal distribution of software files, the RBS informs the BSC that a restart of the RBS is necessary to activate the new software.

38.2.5 Software Start

The activation of new software is ordered via the A-bis interface. When the order is received, the software is copied from non-volatile memory into volatile memory, where it is executed.

At switch-over to the new software, traffic is affected. This implies a restart as in the section *Restart and Recovery* followed by configuration and enabling as specified in the section *Functionality Administration*.

38.3 Operational Conditions

38.3.1 Operation and Maintenance

The visual indicators relevant to Function Change are described in the section *Operation and Maintenance Terminal*.

38.3.2 Capabilities

The download of software via the A-bis to the RBS and internal transfer of software files does not affect the normal operation of the RBS.

Switch-over, i.e. software start of an RBS, takes less than 60 seconds.

The switch-over time is defined as the time elapsed from the reception of a start command via A-bis to when the Main RU is ready for re-establishment of the link to the BSC.

39 Functionality Administration

"Functionality Administration" provides the functionality necessary to allow the BSC to configure, enable and disable AOs within the RBS. This function also includes general layer 3 A-bis OML support for other functions within the RBS.

39.1 References

Whenever a reference is made to a function described in another chapter, please refer to the table of contents to find the appropriate chapter.

39.2 Concepts

| | |
|----------------------|--|
| Elementary Procedure | The protocol over the A-bis OML at layer 3 consists of EPs (Elementary Procedures). An EP is a unit of interaction between the BSC and one of the MOs. An EP consists of an initiating message and a response. For example, an EP may consist of the BSC sending an initiating message CONFIGURE REQUEST and the MO in the RBS responding with a message CONFIGURE REQUEST ACK. |
| RU | Replaceable Unit. An RU is the smallest unit that can be handled on site or in a repair center and of which information can be retrieved via OMT or BSC. |
| AO | Application Object. An abstract subclass of MO, which provides part of the functionality of a BTS |
| MO | Managed Object. The BSC manages the O&M of the RBS via the A-bis O&M Interface. The RBS equipment is seen as MOs by the BSC. This is a means of describing the RBS in a functional-oriented way, and a logical model of the RBS in terms of MOs is built in the BSC. All O&M actions are based on this logical model structure created in the BSC. An MO does not necessarily have a one-to-one relation with a physical unit in the RBS, and the MO comprises either both hardware and software or software only. See also Figure 94 on page 334. |
| SO | Service Object. An abstract subclass of MO, which provides service functions for a set of MO instances including itself. |

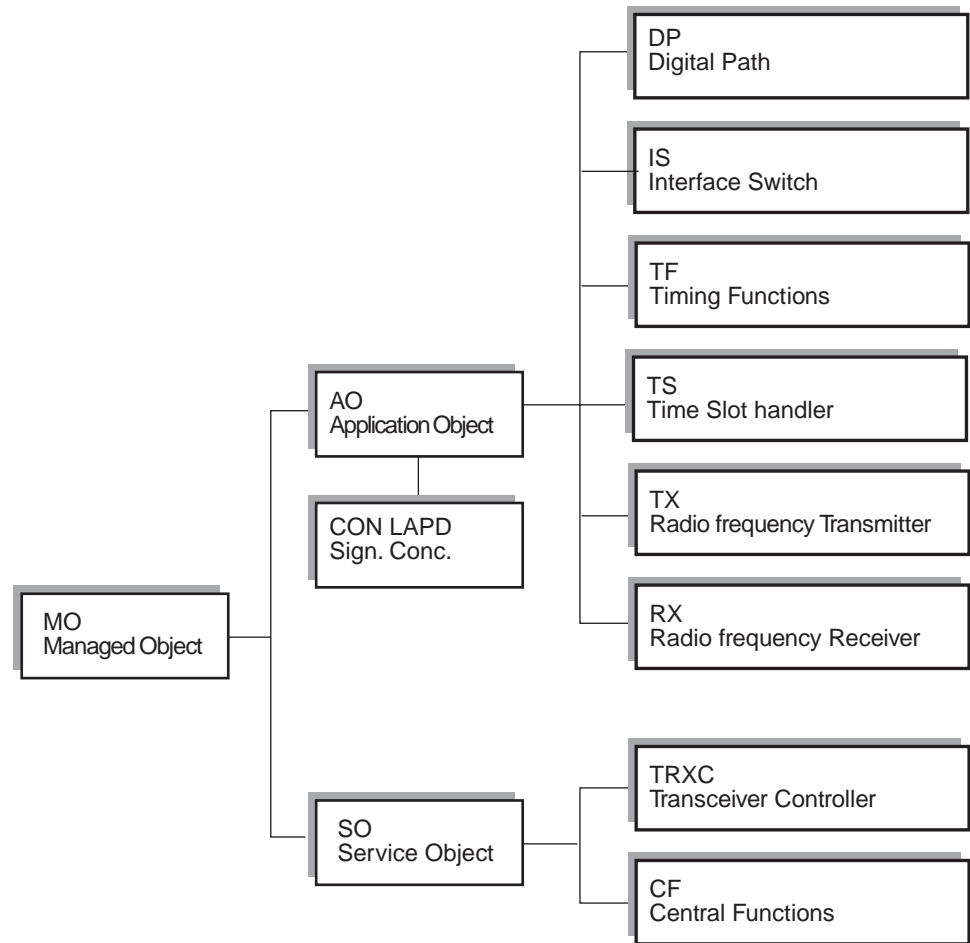

01_0286B

Figure 94 Managed Object classification

39.3 Functions

39.3.1 Application Object Connection

Before the BSC can communicate with an AO instance, that instance must be connected to its associated SO instance. This is performed by a command over the A-bis OML and includes both of the following:

- Connect an AO to an SO
- Disconnect an AO from an SO

39.3.2 Application Object Configuration

Each AO has a number of associated configuration parameters which control the way in which it functions.

An AO has two states relevant to configuration:

- Enabled
- Disabled

The configuration of an AO by the BSC involves three distinct operations performed over the A-bis OML:

- Configuration
- Enable
- Disable

Configuration

The process of setting the desired configuration parameters for an AO.

For most AOs and most configuration parameters this process must be performed while the AO is disabled. However there are a number of exceptions, certain parameters on certain AOs may be configured by the BSC while the AO is enabled.

When a configuration request is received over the A-bis, this function checks that all preconditions for a change in configuration are satisfied:

- All parameters are within the permitted range or have permitted values
- If the AO is enabled, parameters that cannot be changed in enabled state must not be changed
- For certain classes of AO, the configuration parameters must be consistent with each other

The BSC is informed of the successful configuration of the AO or, if unsuccessful, an indication of why the configuration failed is returned.

Enable

Enable attempts to activate an AO with the current configuration parameters.

When an enable request is received via A-bis, this function checks that all preconditions for a change to enabled state are satisfied:

- All required configuration parameters must be previously set by one or more configuration procedures
- Configuration parameters must be consistent with each other

If the checks are all successful, the function of the appropriate AO is enabled.

The BSC is informed of the successful enable of the AO or, if unsuccessful, an indication of why the enable was unsuccessful is returned.

Disable

Disable deactivates an AO.

When a disable request is received over the A-bis, this function only needs to check that all preconditions for a change to disabled state are satisfied.

If the check is successful, the function of the appropriate AO is disabled. The AO IS and AO CON are exceptions to this, they retain their normal functions even when disabled.

The BSC is informed of the successful disable of the AO or, if unsuccessful, an indication of why the disable was unsuccessful is returned.

39.3.3 A-bis OML Support

Layer 3 downlink Elementary Procedures

Downlink EPs are those EPs initiated by the BSC. The initiating message is checked for the following criteria:

- Valid header and message code
- Correct length
- All mandatory parameters are present
- Only mandatory or optional parameters are present
- Parameter values are in range

An initial message that fails to meet any of these criteria is rejected. If the message is so badly corrupted that it is not recognisable, the message is simply ignored.

A message which meets all of these criteria is forwarded to the appropriate handling function. The handling function is then responsible for responding to the initial message.

Layer 3 downlink Precondition Test

This is a general function which is implicitly used by all functions initiated on the Abis O&M interface. It is performed after the general Format Check. The function must not be explicitly referred to.

Layer 3 uplink Elementary Procedures

Uplink EPs are those EPs initiated by the RBS. All functions within the RBS which initiate uplink EPs use this function to provide supervision as defined below.

An initiated EP is time supervised. The initial message of an EP is repeated if timeout occurs before a response is received. The initial message is sent once, and then repeated a maximum of two times.

The response from the BSC is checked for the following criteria:

- Valid header and message code
- Correct length
- All mandatory parameters are present
- Only mandatory or optional parameters are present
- Parameter values are in range

A response message that fails to meet any of these criteria is simply ignored.

A response message that meets all of these criteria is forwarded to the function that initiated the EP.

After a timeout the message is retransmitted. A maximum of 2 retransmissions are performed. After 3 timeouts (including 2 retransmissions) Layer 3 supervision is terminated.

39.4 Operational Conditions

39.4.1 Operation and Maintenance

The visual indicators relevant to Functionality Administration are described within the context of Operation and Maintenance Support.

This page is intentionally left blank

40 Operation and Maintenance Support

Operation and Maintenance Support defines RBS functions related to:

- Buttons
- Visual indicators
- Change from Local to Remote Mode and vice versa
- Loop Control
- RF Loop Test Supervision
- Calendar Time
- RSSI Temperature Compensation

40.1 References

Whenever a reference is made to a function described in another chapter, please refer to the table of contents to find the appropriate chapter.

40.2 Concepts

| | |
|---------------------|--|
| CMRU | Central Main RU. The CMRU belongs to the RU type Main RU. The RBS is physically connected to the BSC via a CMRU. There is only one CMRU in each RBS. |
| DMRU | Distributed Main RU. A Main RU is said to be distributed if it is subordinate to the central main RU, CMRU. |
| Extension Cabinet | In a multiple cabinet configuration, the Extension Cabinet is the cabinet without the SO CF. The Extension Cabinet is connected to a master cabinet and cannot operate without the master cabinet. |
| ILO | In Local Operation (Op. State). When the RBS, CMRU or DMRU is in the state "local operation" the instance can be operated from the OMT. |
| IRO | In Remote Operation (Op. State), the RBS has a link established to the BSC. |
| IU | In Use (Op. State). When the RBS is in state "In Use", the instance is configured and enabled to fulfil its purpose. |
| Local Configuration | When a RU reads necessary information from its database and a signal is sent when it is ready. |
| Main RU | Contains one or more processors, to which SW can be downloaded from the BSC. A |

| | |
|----------------|---|
| | <p>main RU is either central or distributed. A main RU may or may not have a direct signalling link to the BSC.</p> |
| Master Cabinet | <p>In a multiple cabinet configuration, the Master Cabinet is the cabinet with the SO CF. In this document a Master Cabinet is considered to be equal to a stand-alone cabinet.</p> |
| MO | <p>Managed Object. The BSC manages the O & M of the RBS via the A-bis O & M interface. The RBS equipment is seen as MOs by the BSC. This is a means of describing the RBS in a functional-oriented way, and a logical model of the RBS in terms of MOs, is built in the BSC. All O & M actions are based on this logical model structure created in the BSC. An MO does not necessarily have a one-to-one relationship with a physical unit in the RBS and the MO comprises either both HW and SW or SW only.</p> |
| RFU | <p>Ready For Use (Op. State). When in operational state "Ready For Use" the instance is started by the BSC with the correct SW.</p> |
| RSSI | <p>Received Signal Strength Indicator</p> |
| RU | <p>Replaceable Unit. A RU is the smallest unit that can be handled on site or in a repair centre and of which information can be retrieved via OMT or BSC.</p> |
| SO | <p>Service Object. A Service Object is an abstract subclass of MO. A SO instance carries service functions for a set of MO instances, including itself. The Service functions include Layer 2 termination and Layer 3 distribution. They may also include HW supervision and SW handling.</p> |
| Sub-RU | <p>A sub-RU is always connected to a superior main RU. This connection is used for retrieval of equipment information. A sub-RU does not normally have a processor. It should be observed that a RU with a processor that is not loadable is classified as a sub-RU.</p> |
| TDMRU | <p>Transceiver DMRU. A TDMRU is a DMRU that handles transceiver functionality.</p> |

40.3 Buttons

Purpose

To be able to reset, to start test operation function and to change between local and remote mode.

Preconditions

For the CPU Reset-button and the Test-button there are no precondition requirements. For the Local/Remote-button, see Section 40.4 Change RU to Local Mode on page 341 and Section 40.5 Change RU to Remote Mode on page 342. The functions are initiated when the buttons are pushed.

Description

CPU Reset:

A CPU Reset button can be found on the cabinet. When the CPU Reset button is pushed the unit itself and all its sub-units will be reset.

Local/Remote:

A Local/Remote button can be found on the cabinet. The Local/Remote button is used to change RU mode to Local or Remote. For further description of the Local/Remote button, see Section 40.4 Change RU to Local Mode on page 341 and Section 40.5 Change RU to Remote Mode on page 342.

Test:

Test buttons can be found on the cabinet. The Test function is not used.

40.4 Change RU to Local Mode

Purpose

To change from Remote Mode to Local Mode which means to release and stop the layer 2 communication links on Abis interface and to disable MO TX and MO TS if they were enabled.

Preconditions and Initiation

The RU operational state should be IRO, RFU and IU. The RU Mode should be Remote. The function is initiated when the Local/Remote button on the cabinet is pushed.

Description

The Local Mode Indicator starts flashing to indicate that a change of RU mode is in progress. The Operational indicator is turned off if applicable, see Section 40.12 Operational Indicator on page 346 and the Local/Remote button is disabled.

The subfunction Local Mode in Progress is performed, see Section 40.19 Local Mode in Progress on page 350. After this the Local Mode indicator is turned on, the Operational Indicator is handled see Section

40.12 Operational Indicator on page 346 and the Local/Remote button is enabled.

If the RBS is the master cabinet, the SO CF is first taken into LOCAL MODE. Five seconds after the Abis Fault Report elementary procedure is terminated, the SO TRXCs in the master cabinet are taken into Local Mode. If the micro is the extension cabinet, both SO TRXCs are taken into LOCAL MODE immediately.

The following will occur when the function terminates:

- The Local Mode Indicator is turned on.
- The Operational Indicator indicates RU operational mode according to description.
- An external condition class 1, called Toggle Information is raised.

Limitations: The status of the external condition, Toggle Information, is stored in RAM that is not affected by SW reset. During start, the Toggle Information is set if the Local/Remote button is set to Local.

40.5 Change RU to Remote Mode

Purpose

To establish a link towards the BSC.

Preconditions and Initiation

The RU Operational State should be ILO and the RU Mode should be Local. The function is initiated when the Local/Remote button is pushed.

Description

An RU cannot be changed to Remote Mode until the local configuration on the RU has been performed.

The Local Mode Indicator starts flashing to indicate that a change of RU mode to Remote is in progress and the Operational Indicator is handled, see Section 40.12 Operational Indicator on page 346.

If the micro is the master cabinet, all layer 2 communication links in the master cabinet on the Abis interface enter a state where they await a link establishment attempt by the BSC. If the micro is the extension cabinet, the extension cabinet layer 2 communication links on the Abis interface enter a state where they await a link establishment attempt by BSC. By acknowledgement of such an attempt, the link will become established. The RU mode is changed to remote immediately after the OML towards the BSC is established. The external condition class 1, called switch information, is ceased. The ceased external condition is not reported to the BSC. The LOCAL MODE indicator is turned off to indicate that the RU is in REMOTE MODE.

40.6 Change RU to Remote Mode Cancel

Purpose

To cancel a change to Remote Mode when a change of RU mode from Local to Remote is in progress.

Preconditions and Initiation

The RU mode should be "Change to remote mode in progress". The function is initiated when Local/Remote button on RU is pushed.

Description

If the Local/Remote button is pushed during a change from Local to Remote Mode (the Local Mode Indicator will be flashing during the change of RU mode), the attempt of changing RU mode to Remote is interrupted. The Local/Remote button is then disabled.

All layer 2 communication links on Abis interface are released and stopped by RBS (refer to Terrestrial Link Handling Functionality) if they were started.

The Local Mode Indicator is turned on, the Operational Indicator is handled, see Section 40.12 Operational Indicator on page 346 and the Local/remote button is enabled.

At the termination of the function the Local Mode Indicator will be turned on, the Operational Indicator will indicate the RU operational mode according to description and an external condition class 1, called Toggle Information is raised.

40.7 Loop Control

Purpose

To test the transmission network by looping all traffic back to the BSC.

Preconditions and Initiation

The MO state should be Disabled and the RU Mode Remote. The Loop Control is initiated by the Loop Control command on the Abis interface.

Description

The Loop Control procedure is a part of the automatic loop test of speech/data links. The Loop Test can be opened or closed on command from the BSC. When the test loop is closed all traffic is looped back to the BSC in order to test the transmission network. The test loop is controlled by MO TS. The Loop Control is terminated when Loop Control Complete is sent on the Abis interface.

40.8 RF Loop Test Supervision

Purpose

To test the radio equipment during traffic.

Preconditions and Initiation

The RU Mode should be Local or Remote. The RF Loop test Supervision is initiated when the application SW is started.

Description

The radio equipment is tested during traffic by a radio loop test function. The test procedure is described by the Supervision and Selftest functionality.

The supervision parameters are defined by the IDB or the OMT. The supervision parameters define supervision status (active/inactive) and test interval. Each parameter has a default value. When the test loop is activated the test is continuously repeated with the defined test interval. The supervision is terminated at deactivation from the Operation and Maintenance Terminal.

Detected faults at RF Loop Test are handled by the Diagnostics and Fault handling functionality.

The default values are:

Supervision status: active

Test interval: 5 minutes

40.9 Calendar Time Request

Purpose

To update the system time.

Preconditions and Initiation

The RU Mode should be Remote. The Calendar Time Request function is initiated five seconds after the OML for CF has been established, and when RU Mode is switched from Local to Remote.

Description

All main RUs handle a real time clock which is internally used within the RUs as the system time. The system time is updated by the Calendar Time elementary procedure on Abis interface. Calendar time is distributed to all main RUs. System time is then updated for those RUs. Calendar time is periodically requested and updated while layer 2 communication link is established. The request interval is 24 hours. The Calendar Time request function is terminated when OML for SO CF is released and stopped and when RU Mode is switched from Remote to Local.

40.10 RSSI Temperature Compensation

Purpose

To be able to update the RSSI temperature compensation value.

Preconditions and Initiation

Applicable for any RBS operational state. The TMRU Mode should be Local or Remote. The RSSI Temperature Compensation is initiated by the Internal Configuration function in the Restart and Recovery sequence.

Description

The loss in the receiver path varies with the temperature. In order to get a more accurate estimate of the loss, the temperature for the receiver will be measured continuously. The temperature level is then used for update of the RSSI temperature compensation value. The RSSI compensation value will not be updated more frequently than every 10th second.

40.11 Fault Indicator**Purpose**

To indicate if there are any faults in the RU the indicator is located on.

Preconditions and Initiation

Applicable for any operational condition. The function is initiated when the SW is started.

Description

The Fault Indicator is controlled from the Diagnostics and Fault Handling Functionality and from the Restart and Recovery Functionality. When the RU is reset in any way the handling of the indicator is terminated.

| | |
|--------------------|---|
| Colour: | Red |
| Position: | Cabinet |
| ON: | One or more faults are detected in the RU. |
| FLASHING (0.5 Hz): | If the Micro base is the master cabinet: - Running on Base Application OR - One or more faults are detected in the RBS. |
| OFF: | No fault(s) is detected. |
| Priority | ON has a higher priority than FLASHING. If the conditions for two states are fulfilled, the one with the highest priority will control the indicator. |

40.12 Operational Indicator

This section also includes operational states, remote operational indication and operational information.

Purpose

To indicate if the RU is considered Operational/not Operational, if BSC initiated configuration is in progress, if SW is being received or if restart is pending after SW download.

Preconditions and Initiation

Set Operational Indicator:

Applicable for any operational condition. The function is initiated when the SW is started.

Remote Operational Indication:

The RU operational state should be IRO, RFU and IU and the RU mode should be Remote. The function is initiated by OPERATIONAL_INFORMATION on the Abis interface.

Operational Information:

The MO state should be "not reset" and the RU mode should be Remote. The function is initiated by OPERATIONAL_INFORMATION on the Abis interface.

Description

The Operational indicator is controlled from the Diagnostics and Fault handling functionality, Restart and Recovery functionality and Function Change Functionality. The indicator is turned off 2-10 seconds after the SW has started. When the RU is reset in any way the handling of the indicator is terminated.

For description of the Remote Operational Indication function and Operational Information function see the parts of this section called "Operational States" (part "RU in Remote Mode").

Colour: Green

Position: Cabinet

States of the indicator

ON: The RU is considered Operational.

FLASHING (0.5 Hz): - Configuration activity initiated from the BSC, (which may take more than 10 seconds to complete) in progress OR

If the Micro base is the master cabinet:

- SW is being received OR

- Restart pending (after SW download).

OFF The RU is considered Not Operational.

Priority FLASHING has a higher priority than ON and OFF. ON has a higher priority than OFF. If the conditions for two states are fulfilled, the one with the highest priority will control the indicator.

Operational States

Table 112 Operational States

| RU in Remote Mode | RU in Local Mode |
|---|---|
| The state of the operational indicator on the cabinet is determined on the operational mode of the MOs associated to the RU. | The master cabinet is considered operational if SO CF and at least one SO TRXC are considered free from class 1 HW faults and Local Configuration has been performed. |
| The MO operational mode is reported by the BSC with the OPERATIONAL_INFORMATION message. A MO is internally taken out of operation at reset (see chapter Function Change) or when its associated RU is taken into Local Mode. | The extension cabinet (if there is any) is considered operational if at least one SO TRXC is considered free from class 1 HW faults and Local Configuration has been performed. |
| The Master Cabinet is considered operational if SO CF, at least one SO TRXC, and at least one AO RX and at least one AO TS are considered operational by the BSC, set by the message OPERATIONAL_INFORMATION to each MO. | The Remote Operational Indication function is terminated when OPERATIONAL_INFORMATION_ACCEPT is sent on the Abis interface. |
| The extension cabinet (if there is any) is considered operational if SO TRXC, at least one AO RX and at least one AO TS are considered operational by the BSC, set by the message OPERATIONAL_INFORMATION to each MO. | |
| The Remote Operational Indication function and the Operational Information function are terminated when OPERATIONAL_INFORMATION_ACCEPT is sent on the Abis interface. | |

There is one operational indicator per cabinet.

40.13 Local Mode Indicator

Purpose

To indicate the current RU Mode.

Preconditions and Initiation

Applicable for any operational condition. The function is initiated when the SW is started.

Description

After a restart, the indicator is on until the Local Remote handling starts (see chapter Restart and Recovery). When the RU is reset in any way the handling of the indicator is terminated.

Colour: Yellow

Position: Cabinet

States of the indicator

ON: RU Mode is Local.

FLASHING (0.5 Hz): Change of RU mode is in progress:

- Waiting for layer 2 A-bis communication to be established OR
- Waiting for confirmation that the layer 2 A-bis communication has been released.

OFF RU Mode is Remote.

For description of changing an RU to Local Mode, see Section 40.4 Change RU to Local Mode on page 341

Limitations:

The Local Mode indicator will not indicate when the layer 2 A-bis communication with the BSC is lost when the RU Mode is Remote.

40.14 External Alarms Indicator

Purpose

To indicate if any external alarm defined by the operator is active.

Preconditions and Initiation

Applicable for any operational condition. The function is initiated when the SW is started. The functionality is initiated when the RBS DB has been read during the start-up sequence (refer to Restart and Recovery functionality).

Description

The External Alarms indicator indicates if any external alarm defined by the operator is active. The External Alarm Indicator is controlled from External Alarms functionality and from Restart and Recovery functionality. When the RU is reset in any way the handling of the indicator is terminated.

Colour: Yellow

Position: Cabinet

States of the indicator

ON: Any external alarm connected to an inlet in this cabinet is active.

| | |
|--------------------|---|
| FLASHING (0.5 Hz): | Any external alarm connected to an inlet in an extension cabinet is active. |
| OFF | No external alarm connected to an inlet in any cabinet is active. |

40.15 Test Result Indicators (not used)

There are two yellow indicators on the cabinet, one called "Test Result TDMRU1" and one called "Test Result TDMRU2".

The indicators are turned off 2-10 seconds after the SW has started.

40.16 Reduced Capacity Indicator

Purpose

To indicate if at least one of the transceivers in the cabinet is considered NOT Operational.

Preconditions and Initiation

Applicable for any operational condition. The function is initiated when the SW is started.

Description

The Reduced Capacity indicator indicates if both transceivers are Operational or not. The Reduced Capacity indicator is controlled from the Operational function, see Section 40.12 Operational Indicator on page 346 from Diagnostics and Fault handling functionality and from Restart and Recovery functionality. When the RU is reset in any way, the handling of the indicator is terminated.

Colour: Yellow

Position: Cabinet

States of the indicator

ON: At least one of the transceivers in the cabinet is considered Not Operational, see Section 40.12 Operational Indicator on page 346.

OFF: All transceivers in the cabinet are considered Operational, see Section 40.12 Operational Indicator on page 346.

40.17 AC Power on Indicator

Purpose

To indicate if the AC power is turned on.

Preconditions and Initiation

Applicable for any operational condition. The function is initiated by the HW when the RU is started.

Description

The AC Power On indicator indicates if the AC supply is turned on or not. The indicator is controlled from the Power Supply functionality and from the Restart and Recovery functionality. When the RU is reset in any way, the handling of the indicator is terminated.

| | |
|-------------------------|--------------------|
| Colour: | Yellow |
| Position: | Cabinet |
| States of the indicator | |
| ON: | AC Power Supply |
| OFF | No AC Power Supply |

40.18 Battery Fault Indicator

Purpose

To indicate if the battery is faulty or disconnected.

Preconditions and Initiation

Applicable for any operational condition. The function is initiated by the HW when the RU is started.

Description

The battery fault indicator indicates if the battery is faulty or disconnected. The indicator is controlled from the Power Supply functionality and from the Restart and Recovery functionality. When the RU is reset in any way, the handling of the indicator is terminated.

| | |
|-------------------------|--|
| Colour: | Yellow |
| Position: | Cabinet |
| States of the indicator | |
| ON: | The battery is disconnected or faulty. |
| OFF | The battery is connected and no faults are detected. |

40.19 Local Mode in Progress

Local Mode in Progress is a subfunction.

Purpose

To change RU mode from Remote to Local.

Preconditions and Initiation

The RU mode should be "Change to Local Mode in progress". The subfunction will be initiated when a change of RU mode to Local mode has been initiated.

Description

An external condition class 1, called switch information, is raised on the RU.

A Fault Report message is sent to the BSC on the Abis interface to inform the BSC that the unit is taken into Local operation. The RU mode for the cabinet is changed to Local when the Abis fault report procedure is terminated.

When Local Mode has been entered, the layer 2 communication links in Abis interface concerning the SO are released and stopped by RBS (see chapter Terrestrial Link Handling).

On the TDMRU, the MO TX and MO TS are disabled if they were enabled.

The function is terminated when the layer 2 communication links on Abis interface concerning the SO has been released and stopped and Local mode has been entered.

This page is intentionally left blank

41 Installation Data Handling

Information about specific areas regarding either the RBS as a whole or each of the Replaceable Units, RUs, is stored in a database in the RBS. The purpose of the database is to handle information and provide efficient help within the following areas:

- General operation and maintenance
- Fault diagnostics
- Fault localisation
- Traceability

The database mainly contains configuration data valid for the RBS as a whole and for individual RUs.

Of course, the database that handles this information is not public but it is at least partly accessible for:

- The operator who accesses the database via the OMT
- The BSC which reaches the database via the Abis interface
- Other functions within the RBS

41.1 References

Whenever a reference is made to a function described in another chapter, please refer to the table of contents to find the appropriate chapter.

OMT functions related to Installation Data Handling functions are described within the context of Operation and Maintenance Terminal.

41.2 Concepts

| | |
|------|--|
| ARAE | Antenna Related Auxiliary Equipment |
| | Auxiliary equipment affecting the antenna functionality, e.g. active antennas. |

41.3 General

The RBS database is stored in the CMRU which is a part of the RBS. Some parts of the content of the RBS database are relevant for specific RUs and those parts are stored in the Main RUs and sub-RUs.

The Installation Data Handling functions provide basic access to the content of the RBS database. As mentioned above, it is at least partly accessible for:

- the operator via the OMT
- the BSC via the Abis interface
- other functions within the RBS

41.4 Database Information Handling Elements

Several Database Information Handling elements are found in the RBS and RU databases. The most important ones are described below.

41.4.1 Elements Found in the RBS Database

RBS External Alarms

Specifies the alarm identity, alarm data, alarm severity and alarm criterion for each external alarm.

Access: BSC via the Abis interface (in fault reports and hardware information)
Operator via the OMT

RBS ARAE Supervision

Specifies the affected functionality, fault class and antenna instance number of each auxiliary fault.

Access: Operator via the OMT

RBS Transmission Interface Configuration

Stores configuration information for the transmission interface and the TEI for the CMRU.

Access: Operator via the OMT

RBS Configuration Identifier

Identifies the overall RBS configuration.

Access: Operator via the OMT

41.4.2 Elements Found in the RBS and RU Databases

RU Type

Describes the RU type and the RU instance in detail.

Access: Operator via the OMT

RU Identity

Includes product number, revision and serial number of the RU.

Access: BSC via Abis (in fault reports and hardware information)
Operator via the OMT

RU Physical Position

Identifies the location of the RU at a site, including information about cabinet, rack, shelf and slot.

Access: BSC via the Abis interface (in fault reports and hardware information)
Operator via the OMT

41.4.3 Elements Found in the RU Database

RU Specific

Includes the parameters specific to an RU. These parameters are dependent on the hardware design.

41.5 Functions

There are a number of functions and services connected to the Installation Database Handling. Some examples follow:

41.5.1 Read/Install the RBS Database

The entire RBS database can be both read and written. These functions are used when the RBS database needs to be transferred between the OMT and the RBS.

41.5.2 Read Hardware Information

This function makes it possible for the BSC to read detailed information from the hardware installed in the RBS, for example:

- Product number
- Revision
- Serial number
- Physical position

41.5.3 Read Information Element

This function allows the RBS to read information elements in the RU and RBS databases.

41.5.4 Write Information Element

This function makes it possible for the RBS to write information elements in the RU and RBS databases.

41.6 Operational Conditions

A reading of the entire RBS database from the RBS to the OMT takes less than four minutes.

An installation of the entire RBS database, from the OMT to the RBS, takes less than four minutes.

This page is intentionally left blank

42 Self Test and Supervision

Self Test comprises an initial boot test and X-bus receiver test. The initial boot test is performed during the start-up of an RU, in order to test the functionality of the hardware required for the execution of the application software. The X-bus receiver test is performed at TX configuration if TX is configured for SW Power Boost, in order to test the X-bus receiver on the master TX and slave TX.

Supervision is a subsequent activity, which continuously monitors the correct function of all supervised entities within the RBS. Faults detected by the supervision function are passed to the Diagnostics and Fault Handling function for further processing.

42.1 References

If a reference is made to a function described in another chapter please refer to the table of contents to locate the relevant information.

42.2 Concepts

CRC Cyclic Redundancy Code (CRC code).
The CRC code is often called polynomial code.

42.3 Self Test

42.3.1 Boot Test

Purpose

The Boot test is an initial test function that determines the functionality of the RBS hardware. The test ensures that the application software can be started in the processor.

Preconditions and Initiation

The Boot test is carried out before any normal application processes are started. The function Restart and Recovery invokes the test.

Description

Invoked by the function Restart and Recovery the processors are tested implicitly by the memory test.

Read/write memories are tested before any other functions. These tests are fast and destructive to the contents of the memory and control the two alternate states of a memory bit are tested.

Memory of non-volatile character such as flash and eeprom is tested checksums. The checksum must include the whole content of the memory, but does not include unused memory with predefined values to save time and start-up.

Finally, HW functions controlled by the processor, which are necessary to start the application software and which do not disturb other processes or associated HW are finally tested.

The Boot Test returns a state that indicates failure or success. However, the test will terminate permanently if a Read/Write-memory failure is detected. This causes a reset of the processor. The function can be upgraded remotely by replacing parts of the boot software.

42.3.2 X-Bus Receiver Test

Purpose

To detect any faults on the X-Bus before the SW Power Boost is started.

Preconditions and Initiation

Initiated by the functionality administration when an AO TX instance that is configured for SW Power Boost is enabled.

Description

The X-Bus receiver on the master TX and slave TX is tested by sending a test message on the X-Bus. It is terminated by reporting the outcome of the test.

42.4 Supervision of Memory

Purpose

Controlling the correctness of the memory contents.

Preconditions and Initiation

The Boot Test is carried out before any normal application processes are started. The function Restart and Recovery invokes the test.

Description

There are two kinds of memory, Read/Write memory and a Read only memory.

The Read/Write memory is supervised by parity checking. A parity bit is added to the data and is chosen so that the number of 1 bits in the data is even (or odd). For example, when using even parity the data 1011001 becomes 101101011 and the data 10110001 becomes 101100010. Parity bits are added when writing data to the memory and these bits are checked when reading the same data from the memory. If the parity bits are not even (or odd) a fault has occurred in the data.

The read only memory (and memory of non-volatile character such as Flash and EEPROM) is supervised by continuous control checksum (CRC-32). When copying a data burst from a non-volatile memory to a volatile memory both the original data burst and the copy must be checked. If a fault is detected the fault is reported to the fault handling functions.

42.4.1 Supervision of Buses

Purpose

The purpose of this function is to check the integrity of the data on the buses.

Preconditions and Initiation

The function is automatically initiated at the start of the functions driving and receiving information on the buses.

Description

Receive and transmit bus supervision encompasses buses between three or more RUs or major functional blocks. The address or data buses of the processors are not supervised by this specific function. The supervision of the buses is achieved by comparison of data sent to the bus driving function with the information on the bus, and by control information embedded in the data. The function looks for expected traffic on the bus. Traffic must be generated in absence of normal traffic. Disturbances are reported to fault handling for filtering and fault detection.

42.4.2 Supervision of Cables

Purpose

To detect removal of a cable.

Preconditions and Initiation

Initiates automatically at start of application software.

Description

All cables between the RUs are supervised. Removal of a cable during operation is always detected by one of the following conditions:

- No current in the cable
- Missing logical signal
- Missing traffic message

It is possible to disable and enable the fault reporting for the cables listed below using the OMT.

- CDU TRU PFWD cables
- CDU TRU PREF cables
- FU CU PFWD cables
- FU CU PREF cables

When the OMT is disconnected, the fault reporting is always enabled.

42.4.3 Supervision of Application Program

Purpose

Supervises the application software. If the execution of the software fails (for example a cyclic loop) the function exception processing interrupts the execution.

Preconditions and Initiation

Initiates automatically at start of application software.

Description

The main processor supervises the operation of the sub-processors by the regular reception of signals from the sub-processors. When no normal operation signals are generated dummy signals will be generated instead. Dummy signals generated from a subprocessor, tell the main processor that the sub processor is still in an operational state.

The main processor receives exceptions from a number of sources such as arithmetic overflows, I/O interrupts, system calls and when no operational or dummy signals from the sub-processors are generated. When the processor detects one of these exceptions it disables interrupts and forces execution of a software exception processor (called the handler) located at a fixed address. The handler saves the contents of the processor, including the context of the program counter, the current operating mode (user or supervisor) and the status of the interrupts (enabled or disabled). These contents are saved so it can be restored when the execution has been serviced. When an exception occurs, the CPU loads the Exception Program Counter (EPC) register with a location where execution can restart after the exception has been serviced.

42.4.4 Supervision of DMRU Loadfiles

Purpose

The function investigates that loadfiles are correctly stored in CMRU memory.

Preconditions and Initiation

The CMRU application software is loaded and activated. The function is then activated when the CMRU detects loadfiles in the DMRU that are expected in the CMRUs non-volatile memory. These are then transferred from the DMRU to the CMRU.

Description

The loadfiles in the non-volatile memory of the CMRU are supervised by continuous comparison of checksum. Detected errors are reported to the function Diagnostics and Fault Handling. The checksum comparison on each supervised loadfiles is performed with 5–minutes intervals. This supervising function has low system priority and is performed as a background activity.

42.4.5 Radio Transmission and Reception

Purpose

The transceiver is tested during traffic by a radio test loop function. The purpose is to detect a faulty transceiver by detecting an error in the signal strength or in the number of bit errors.

Preconditions and Initiation

The test requires two unused ATSR (AirTime Slot Resources) separated by three timeslots. The radio test loop function is initiated when the application software is started and is activated every fifth minute and is performed only if resources are available.

Description

The transceiver is tested by sending a dummy burst to the transmitter unit and looped back internally to the radio receiver unit. The test is performed in two steps, a primary test and, if necessary, a retest if the primary test fails. All loops are performed on the diversity channels A and B and the results from these channels are combined. A fault report is issued if at least one channel indicates an error. All transceivers are tested.

The output power to the antenna is turned off for the ATSR used in the loop. The primary test issues one dummy burst. The signal level of the looped burst for both the A- and B-channel returning to the receiver unit is compared with the sent burst and must exceed a lowest level. The number of detected bit errors must be less than a maximum permitted level. If the test is passed, the test is terminated and no fault is indicated.

If the primary test fails, a retest is performed. This test issues a preconfigured number of dummy bursts, and for each of these bursts, the looped signal level must exceed the lowest level. If the lowest level is not exceeded, the test is terminated and a fault is indicated.

The presence of an interferer is detected by measuring the mean signal level of all the looped bursts. This is done for both the A- and B-channels. If the signal exceeds a maximum defined level, an interferer is considered present.

If no interferer can be detected a final test of the bit error rate is conducted. If the number of bit errors exceeds a maximum permitted number a fault is reported. If all configured retests have failed and not recovered, the transceiver is blocked by the BSC.

42.4.6 Transmitter Antenna

Purpose

Transmitting characteristics are monitored in order to detect if an antenna has been damaged.

Preconditions and Initiation

Initiates when the signalling multiplexing application is started in the CMRU and when the corresponding application handling the signalling endpoints on the DMRUs, are started.

Description

The relation between the reflected power and the output power can be described by the voltage standing wave ratio (VSWR). The more reflection the higher value of the VSWR. At no reflection at all the value of VSWR will be equal to 1 and at total reflection the value of VSWR will be very large. The higher value of the VSWR the higher value of the return loss.

There are two kinds of return loss the Tx feeder return loss and the Tx feeder normal return loss. The Tx feeder Return loss, i.e. the RF attenuation between the RBS cabinet and the antenna (the cable and cable connections) including an ALNA shall be in the interval 0-4dB. The Tx feeder normal Return loss, i.e. the total attenuation from the RBS cabinet and to the antenna and back to the cabinet (i.e. the attenuation at the cable to the antenna and from the antenna, cable connections, ALNA, and the antenna). The attenuation should be \leq 14dB if the Tx feeder loss is \leq 2dB and \leq 18dB if the Tx feeder loss $>$ 2dB. If VSWR is too high a message is sent to the fault handling. It is possible to set two disturbance parameters from the OMT.

The two disturbance VSWR levels are in the range of 1.5-2.8. Allowed alarm level VSWR values are: 1.5, 1.6, 1.7, 1.8, 2.0, 2.2, 2.5, 2.8. The transmitter at the TRU measures the VSWR signal and if the signal is too high it may be harmful to the power amplifier. If the VSWR signal is too high the transmitter may reduce or turn off its output power.

42.4.7 Receiver Antenna

This is described within the context of Diversity Supervision

42.4.8 Layer 2 Data Link Transmission**Purpose**

To check the number of aborted and erroneous frames received by the CMRU from the DMRUs.

Preconditions and Initiation

Initiated when the signalling multiplexing application is started in the CMRU and when the corresponding application handling the signalling endpoints in the DMRUs is started.

Description

Signal messages between the CMRU and the endpoints of the DMRUs are supervised by the following events and conditions:

- Number of aborted frames received
- Number of error frames received

Aborted frames are those frames ended by an abort flag sequence. Erroneous frames have the following conditions:

- A CRC-error (Cyclic Redundancy Code, CRC-16).
- Frames shorter than 4 bytes.
- Frames longer than the maximum frame length (260 bytes).
- Not ended on byte boundary.
- Data loss caused by lack of buffers or memory access problems.

Disturbances are generated such that all malfunctions related to these are detected and can be pinpointed by diagnostics, without generating false alarms.

This supervision is performed with internal links using HDLC type transmission.

42.4.9 Supervision of LAPD Concentration

Purpose

The purpose is to supervise the length of concentrator uplink message queues. A fault report is sent when an overflow occurs.

Preconditions and Initiation

The supervising function is initiated when the LAPD concentrator is started.

Description

The purpose of LAPD concentration is to reduce the number of required physical links between the BSC and the RBS on the Abis interface. This is achieved by letting a number of DMRUs use the same subrate for LAPD signalling on A-bis. To accomplish this, the CMRU shall concentrate LAPD uplink messages from a number of DMRUs onto one physical link to the BSC.

The LAPD concentration function is modelled on A-bis with a managed object, AO CON, which is supported by the RBS.

The supervising function checks the concentrator uplink queues in the CMRU. If the maximum queue time for a message is exceeded, the oldest message in the queue shall be removed when a new is inserted. The fault criteria is set to generate a fault when the message queue is more than 70% full, or when the message is discarded due to queue overflow. Fault messages are not removed. The queue time is calculated using the total number of bytes in the queue and the transmission speed between the BTS and the BSC. The maximum queue time is set to 120 ms. That corresponds to 960 bytes at a transmission speed of 64 kbps.

42.4.10 Supervision of Environmental Conditions

Purpose

Controlling the climate in the BTS.

Preconditions and Initiation

Initiates automatically at application software start.

Description

All BTS have inbuilt fans, which may run at four different speeds full, middle, low and stop. The main task of the fans is to circulate the air in the BTS and replace old, warm air with new, cooler air. The RBS 2102 and 2101 has a climate system with a control unit that controls the temperature and the humidity of the RBS. The control unit is divided into three units:

| | |
|-----|---|
| ECU | The ECU supervises the climate unit, handles the alarms and controls the FCU. |
| CCU | The CCU controls the climate unit independently, but in case of abnormal function the ECU can disconnect the climate unit and override the CCU, (emergency stop). |
| FCU | The FCU is a speed control of the magazine fans and a distributor of their alarms. |

The climate unit consists of among other things a heater, temperature- and humidity sensors, a compressor and a condenser. The compressor will start at an initial temperature of 32°C and will stop when the temperature falls to 25°C. If the enclosure temperature falls below 10°C, the heating unit will be switched on and it will be switched off when the temperature rises above 15°C.

The cabinet heating up time to >0°C depends on the ambient temperature and the time the cabinet has been shut down. However, the heating up time shall not exceed 2 hours under any circumstances.

42.4.11 Power Conditions**Purpose**

Supervises the units used for energy control and the power level of the AC and DC power.

Preconditions and Initiation

Initiates automatically at activation of the application software.

Description

Supervises the units used for energy control. Detects faults in those units for example power supplies, internal or external batteries, fans, cooler, heater or climate sensors. Supervises the power level for AC power and DC power. AC mains failure is detected.

42.4.12 Synchronization Sources

Purpose

Supervise the ability of the transmitter and the receiver to lock to the reference frequency.

Preconditions and Initiation

Initiated when the application software is started. The faults associated are installed in the fault handling function at initiation.

Description

Frequency generators of the transmitter and receiver are supervised for adequate locking to the reference frequency. Failure to lock within time generates a disturbance. Ability to stay locked to reference is monitored until a new frequency is set. Disturbances are reported to fault handling for filtering and eventually fault detection. The supervision of the frequency source is restarted each time a new frequency is set.

42.4.13 Tower Mounted Amplifier

Purpose

Supervises the functionality of the TMA.

Preconditions and Initiation

Initiates automatically at application software start.

Description

The faults associated are installed in the fault handling function at initiation. The functionality of the TMA is supervised by measuring the power consumption of the TMA. A disturbance is generated if the power consumption is outside a predefined interval.

42.4.14 Supervision of Door Alarm

Purpose

Detection of opening the cabinet door or the mounting base door.

Preconditions and Initiation

Automatically at application software start.

Description

A disturbance is generated when the cabinet door or the mounting base door is opened. The disturbance is reported to the fault handling for filtering and eventual fault detection. When raising a fault, there is a short filtering time to avoid contact bouncing. It takes approximately 5 minutes after the fault has been deactivated (that is to say the door has

been closed) for the fault message to cease. The fault is reported as External Condition Fault. This function is valid for the outdoor cabinets only.

43 Diagnostics and Fault Handling

"Diagnostics and Fault Handling" supervises the handling of faults and disturbances detected by the "Selftest and Supervision" function.

Fault handling performs the following:

- Filters spurious disturbances. (Disturbances are events which may indicate a fault only under certain conditions)
- Evaluates the underlying fault cause
- Determines the impact of a fault
- Localizes faults to an offending RU
- Attempts to minimise the effect of a fault
- Reports any change in fault status of an MO to the BSC
- Maintains logs of faults

43.1 References

Whenever a reference is made to a function described in another chapter, please refer to the table of contents to find the appropriate chapter.

Maintenance functions related to Diagnostics and Fault Handling are described within the context of Operation and Maintenance Terminal.

The visual indicators relevant to Diagnostics and Fault Handling are described within the context of Operation and Maintenance Support.

43.2 Concepts

| | |
|-------------|---|
| AO | Application Object. An AO is an abstract subclass of MO. AO provides a part of the functionality of a GSM BTS. The functionality is specified for each concrete descendant class. An AO instance has O&M communication with BSC on Layer 3 via a SO instance. |
| Disturbance | An event which may indicate a fault only under certain conditions. |
| Fault map | Information about a ME fault status is stored in fault maps capable of indicating the presence or absence of all possible faults for a ME. |
| HWU | An Hardware Unit (HWU) consists of one or more SEs. An HWU is a functional unit within the RBS. The HWU is either active (equipped with a processor) or passive (without a processor). |
| ME | Managed Entity. A HWU, RU, SO or AO. |
| MO | Managed Object. The BSC manages the O&M of the RBS via the A-bis O&M |

| | |
|----|---|
| | <p>Interface. The RBS equipment is seen as a set of MOs by the BSC. (This is a way of describing the RBS in a functional-oriented way. A logical model of the RBS in terms of MOs is built in the BSC). All O&M actions are based on this logical model structure created in the BSC.</p> <p>An MO does not necessarily have a one-to-one relation with a physical unit in the RBS and the MO comprises either both hardware and software or software only.</p> |
| RU | <p>Replaceable Unit. An RU is the smallest unit that can be handled on site or in a repair center and of which information can be retrieved via OMT or BSC.</p> |
| SE | <p>Supervised Entity. It is the lowest level in the RBS hardware model. A SE is a property, which is supervised. Examples on SEs are communication fault on a bus and interruption on a PCM reference.</p> |
| SO | <p>Service Object. A SO is an abstract subclass of MO. A SO instance carries service functions for a set of MO instances, including itself. The service functions include Layer 2 termination and Layer 3 distribution. They may also include HW supervision and SW handling.</p> |

43.3 Fault Detection

Purpose

This function detects hardware and functionality faults in the RBS system. The RBS always supervises itself, even without traffic.

Preconditions and initiation

The selftest and supervision function has detected a disturbance.

Description

The fault detection function is processed by the following subfunctions; fault filtering, fault evaluation and fault classification. These subfunctions are described below in detail. The types of faults that are detected are specified within the context of “Selftest and Supervision”.

43.3.1 Fault Filtering

Purpose

The purpose of the subfunction is to determine whether a fault is present or absent, see figure below, and the nature of the fault.

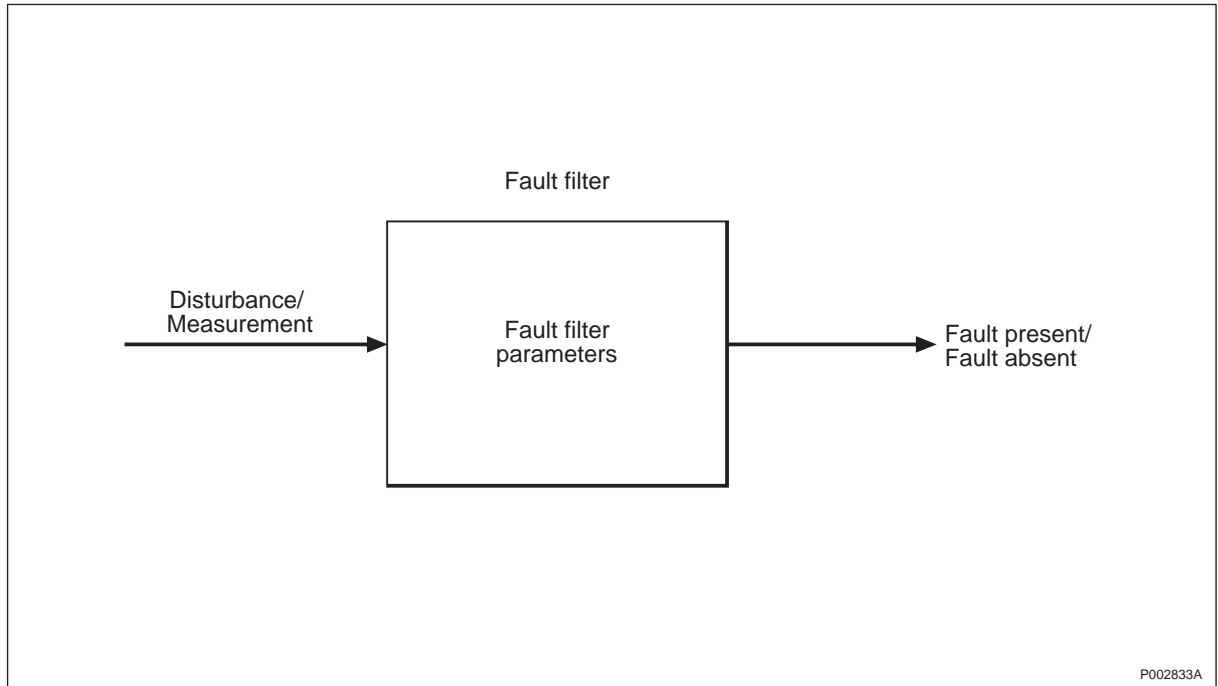

Figure 95 Fault Filter

Preconditions and initiation

The selftest and supervision function has detected a disturbance.

Description

All disturbances are filtered before a fault is considered to be present or absent. The filtering function is adapted to each fault situation for optimum performance. Each fault has its own specified fault filter parameters. For example, the following parameters (or combinations of parameters) may be used for the filter function:

- Frequency of disturbances
 - A frequency which is too high is considered to be a fault
- The measurement value of a parameter
 - A parameter exceeding a threshold is considered to be a fault.
- Time
 - A condition which is valid for too long is considered to be a fault

43.3.2 Fault Evaluation

Purpose

Detected faults are evaluated to determine the underlying fault.

Preconditions and initiation

A change in fault status for HWU or a RU.

Description

This function evaluates the input fault maps and tries to find out the actual fault cause. This is done by analyzing faults reported on a low level (specified hardware units) and mapping them to a high level (RUs and MOs), thus taking the complete fault situation into account.

43.3.3 Fault Classification

Purpose

The fault classification subfunction decides the severity of the fault, whether it affects functionality of the MO or not and also if the fault is internal or external.

Preconditions and initiation

The fault filtering function or the fault evaluation has detected or ceased a fault.

Description

Faults detected by an MO are classified according to:

- Severity
 - Either affects (may affect) functionality of the MO or does not affect functionality of the MO
- Fault origin
 - Either internal or external to the MO
 - Either internal or external to the RBS

43.4 Fault Localization

Purpose

This function is used to localize a detected fault to possible faulty RU.

Preconditions and initiation

The fault detection function has found a change in fault status for a RU.

Description

When detecting a fault, the RBS automatically evaluates the fault situation and indicates the suspected faulty RU. The fault status of the RBS is updated with this information.

When a fault is pin-pointed to a specific RU this is visually indicated as specified within the context of Operation and Maintenance Support.

43.5 Local Action**Purpose**

When a fault is detected for a SE it may be necessary to minimize the effect of the fault. It is called a local action.

Preconditions and initiation

The fault detection function has detected a fault for a SE.

Description

The impact of certain faults can sometimes be minimized by local actions. This is done automatically by the RBS.

Permitted actions are:

- Re-initiation
 - Certain faults can sometimes be cleared by re-initiating the offending hardware. For example, if a communication circuit behaves unexpectedly, it is reinitiated. Note that re-initiation of an entire RU or a processor is not allowed as a local action.
- Fault isolation
 - If a detected fault could cause equipment damage, the equipment is isolated. For example, if a transmitter is overheated, it is switched off.
- Fault compensation
 - Certain faults can sometimes be compensated for elsewhere in the RBS. For example, if a fan is faulty, the speed of the other fans is increased.

Supervision continues after performing a local action. If the fault ceases, the local action is stopped.

43.6 Fault Reporting**Purpose**

This function reports MO faults to the BSC.

Preconditions and initiation

The fault detection function and the fault localization function reports new fault status for a MO. Both functions must have been completed before start of this function.

Description

The RBSs automatically informs the BSC of each change in the fault status. The old fault status is compared with the new fault status. If the fault status has changed for MO, a fault report procedure is initiated on A-bis. A certain fault can be detected and reported by several MOs.

The BSC may request the current fault status for a specified MO at any time.

43.7 Fault Logging

Purpose

All fault changes are logged in the SW log with timestamp.

Preconditions and initiation

A fault has been raised or ceased by the fault filtering function and fault classification function.

Description

All changes in the fault status of the RBS are logged in a software log. The software log is distributed on the RUs. A log entry is stored in the RU where the fault is detected. The software log is stored in volatile memory.

43.8 RBS Diagnostics

Purpose

The purpose of this function is to make conclusions about where the original fault source is located.

Preconditions and initiation

The fault detecting function has reported a change in fault status for a HWU.

Description

The diagnostics function has access to fault maps for the whole RBS, not only for a MO. The RU fault map has information about which information SE(s) that has reported a fault. If there is any fault at the RBS, this function will switch on "BS Fault Indicator". If this function can pinpoint the fault to a RU with 100% probability, it will switch on the Fault Indicator on that RU. If the fault affects functionality and the RU is not in remote mode then the Operational Indicator on the RU will be switched off.

44 Operation and Maintenance Terminal

The OMT is a tool that provides efficient aid for installation, site acceptance, diagnostics and maintenance of RBSs within the RBS 2000 series.

44.1 References

/G.703/ CCITT Recommendation G.703, White Book

/G.704/ CCITT Recommendation G.704, White Book

/GSM:11.20/ GSM 11.20 (phase 1) version 3.11.0

/GSM:05.05/ GSM 05.05 (phase 2) version 4.10.0

Whenever a reference is made to a function described in another chapter, please refer to the table of contents to find the appropriate chapter.

44.2 Concepts

| | |
|-----------------------|---|
| Installation Database | Each RBS has a built-in database where information about installed hardware is stored. The information reflects the configuration as well as the history of the hardware. Within the RBS, each RU carries a database. The installation database is used by the operator (via the OMT), by RBS internal functions and partly by the BSC (via A-bis). |
| MO | Managed Object. The BSC manages the O&M of the RBS via the A-bis O&M Interface. The RBS equipment is seen as MOs by the BSC. This is a means of describing the RBS in a functional-oriented way, and a logical model of the RBS in terms of MOs is built in the BSC. All O&M actions are based on this logical model structure created in the BSC. An MO does not necessarily have a one-to-one relation with a physical unit in the RBS, and the MO comprises either both hardware and software or software only. |
| Spare Bits | A number of additional bits for spare use in a timeslot 0 multiframe structure. This is defined in /G.704/. The use of these bits is defined by the customer. |
| Timeslot 0 | The timeslot 0 multiframe structure is defined in /G.704/. |

| | |
|------------|---|
| CMRU | Central Main Replaceable Unit. An RBS has exactly one CMRU. In the RBS 2000 hardware architecture, the DXU is the CMRU. |
| DMRU | Distributed Main Replaceable Unit. A Main RU is said to be distributed if it is subordinated to the CMRU. |
| Main RU | Contains one or more processors, to which software can be downloaded from the BSC. A Main RU is either central or distributed, see above. A Main RU may or may not have a direct signalling link to the BSC. |
| Passive RU | A passive RU is an RU with a very low level of intelligence. It is independent of the processor system, for example, it has no connection for O&M communication. In the RBS 2000, for example, the cables are Passive RUs. |
| RU | Replaceable Unit. An RU is the smallest unit that can be handled on site or in a repair center and of which information can be retrieved via OMT or BSC. |
| Sub-RU | A Sub-RU is always connected to a superior Main RU. This connection is used for retrieval of equipment information. A Sub-RU normally does not have a processor. Note that an RU with a processor that is not loadable, is classified as a Sub-RU. In the RBS 2000 hardware architecture, for example the CDUs are Sub-RUs. |

44.3 Functions

44.3.1 User Interface

The OMT provides an easy-to-use graphical user interface. Well-known hardware units and functions, for example, a transmitter, appear as graphical objects. There are a number of operations attached to each graphical object, for example for retrieving information about it.

The user interface is based on a number of views. Each view contains a set of objects, chosen so that the natural work flow of the user is supported.

For user convenience there is an on-line help facility in the OMT.

44.3.2 Radio Base Station

The following user functions, related to the RBS as a whole, are available in the OMT:

- Display RBS configuration, see the chapter "Installation Data Handling".

Configurations possible to display, comprise all RBS 2000 products and the configurations as specified for each product.

The following RU and connections are graphically displayed:

- DXU
 - TRU
 - ECU
 - CDU
 - Local bus
 - CDU bus
 - Number of antenna systems (1 or 3)
- Display RBS software revisions, display RU software revisions for all Main RUs, see the section Replaceable Unit.
 - Display TEI/RU list, display list of TEI and RU Instances for the CMRU and for the DMRUs with a direct signalling link to the BSC in the cabinet (see also the paragraph 1.3.10 Replaceable Unit).

The functions above are normally used for:

- General purpose (display RBS configuration)
- Maintenance (display RBS software revisions)
- Installation (display TEI/RU list)

44.3.3 OMT Connection

The following user functions, related to the OMT, are available in the OMT:

- Connect, establish a connection between the OMT and the RBS. A functionality and compatibility check is performed on RBS and OMT software versions. If the OMT is connected remotely an RBS address can be given in order to select one of several RBSs connected in a multidrop chain. In case of different versions the OMT operator is informed about this fact and that all functionality is not supported.
- Disconnect, release the connection between the OMT and the RBS.

The functions above are for general purpose use.

44.3.4 Installation Database

The following user functions, related to the IDB, are available in the OMT:

| | |
|----------------------------|--|
| Read | Copy the IDB from the RBS to the OMT. |
| Install | Install the IDB from the OMT to the RBS. |
| Cable mounting list | Display a cable mounting list based upon information from the IDB. |
| Display site specific data | Site specific data, that is, IDB information that is changeable from the OMT, is displayed. |
| Export site specific data | Copy site specific data from the IDB to other media. |
| Import site specific data | Copy site specific data to the IDB from other media. |
| Save | Copy the IDB from the OMT to any file medium, for example a floppy disk or a hard disk. |
| Open | Copy the IDB from any file medium to the OMT. |
| Display inventory list | An inventory list, containing RU data, based upon information from the IDB, is displayed, saved on file medium or printed. |
| Configure | Generate a new configuration. |
| Modify | Increase or decrease the number of activated RUs in the IDB. |

The functions above are for general purpose use.

44.3.5 External Alarms

The following user functions, related to the external alarms, are available in the OMT:

- Display external alarm setup, display the external alarm setup parameters (see chapter External Alarms) associated with each of the external alarm inputs
- Define external alarm setup
- Monitor external alarms status, the status (on/off) of the external alarms is continuously monitored and displayed

The output can be displayed or directed to file (output stored in a file on the OMT).

The functions above are normally used at:

- installation (display/define external alarm setup)

- site acceptance (monitor external alarms status)

The fault status for all inlets defined for auxiliary faults can be monitored.

44.3.6 ARAE Supervision Parameters

The following user functions, related to the ARAE , are available in the OMT:

- Auxiliary Faults are possible to define for each alarm inlet.
- The alarm inlets can be used for both External Alarms and for ARAE Supervision.
- The definition of the ARAE Supervision Parameters is displayed.
- Monitor ARAE fault status.

The output can be displayed or directed to file (output stored in a file on the OMT).

44.3.7 Modify TN O&M Values

This function modifies the Transport Network O&M parameters in the IDB. There are three TN O&M parameters in the TNOM_information element that are possible to modify:

TNOM_use. Indicates if TN O&M functionality is activated or not.

TNOM_timeslot. Indicates which 64 kbit/s timeslot on the PCM link to use for TN O&M communication.

TNOM_nodeid. Holds the identity of the BTS node in the TN O&M network.

44.3.8 Display TN O&M Values

This function displays the value of the TN O&M parameters, which are stored in the TNOM_information element in the IDB (see parameters above).

44.3.9 Calibration of Optional Reference Oscillator

This function is used to calibrate the optional reference oscillator.

44.3.10 Cable Loss

The following user function, related to Cable loss, is available in the OMT:

- Define cable loss, defines cable and feeder loss values.
- Display cable loss, displays cable and feeder loss values.

44.3.11 ALNA/TMA Parameters

The following functions, related to ALNA/TMA parameters are available in the OMT.

- Define ALNA/TMA parameters.

In OMT state LOCAL and in OMT state CONNECTED, it is possible to define values for the following:

- Current Supervision Limits
 - Current Supervision Limit Low
 - Current Supervision Limit High

It is possible to define values for the following parameters only in OMT state LOCAL:

- RX Group Delay
- Loss
- RX Frequency Range
 - RX Frequency Low
 - RX Frequency High
- Display ALNA/TMA parameters, displays any of the following parameters associated with ALNA/TMA:
 - Current Supervision Limits
 - Current Supervision Limit Low
 - Current Supervision Limit High
 - RX Group Delay
 - Loss
 - RX Frequency Range
 - RX Frequency Low
 - RX Frequency High

44.3.12 PCM Network

The following user functions, related to the PCM network, are available in the OMT:

- Set transmission interface type, sets transmission interface type in the database to G.703 2048 kbit/s or DS1 1544 kbit/s.
- Modify available synchronization source sets whether PCM link A and B, or anyone of them is to be available as synchronization source. Possible settings are: Activated or Not activated.
- Display available synchronization source displays whether PCM link A and B, or anyone of them is available as synchronization source. Possible settings are: Activated or Not activated.
- Set Network_topology value.
Sets Network_topology value for stand alone or cascade connection of RBSs.
- Display Network_topology value.

Displays whether the network topology of the RBSs is stand alone or cascade connection.

The following user functions, related to the /G. 703/ 2048 kbit/s PCM network, are available in the OMT:

- Display spare bits, display spare bits in timeslot 0 on G.703, values (0 or 1) for bits Sa4-Sa8.
- Define spare bits (bits can be defined independently of each other).
- Display CRC-4 (Cyclic Redundancy Check /G.704/), display whether handling of CRC-4 in timeslot 0 on G.703 is on or off.
- Switch on CRC-4.
- Switch off CRC-4.
- Monitor maintenance data, display PCM reference data and update changes continuously.
- Modify PCM Receiver Sensitivity

Sets the individual PCM Receiver Sensitivity values for an E1 transmission interface. The values are defined and referred as parameters PCM-A-REC-SENS and PCM-B-REC-SENS in the IDB.

- Display PCM Receiver Sensitivity

Displays the individual PCM Receiver Sensitivity values for an E1 transmission. The values are defined and referred as parameters PCM-A-REC-SENS and PCM-B-REC-SENS in the IDB.

The following user functions, related to the /DS1/ 1544 kbit/s PCM network, are available in the OMT:

- Modify LBO values for transmission interface.

Sets the individual LBO values for a T1 transmission interface. The values are defined and referred as parameters LBO-A and LBO-B in the IDB.

- Display LBO values for transmission interface.

Displays the individual LBO values for a T1 transmission interface. The values are defined and stored as parameters LBO-A and LBO-B in the IDB.

- Modify FDL use values for transmission interface.

Sets the individual Facility Data Link (FDL) use values for a T1 transmission interface. The values are defined and referred as parameter "FDL_use" in the IDB.

- Display FDL use values for transmission interface.

Displays the individual FDL use values for a T1 transmission interface. The values are defined and stored as parameter "FDL_use" in the IDB.

The functions above are normally used at:

- Installation (set transmission interface type, set/display available synchronization source, display/define spare bits, display/switch on/switch off CRC-4).
- Maintenance (monitor maintenance data).

44.3.13 Antenna System

The following user functions, related to the antenna system, are available in the OMT:

- Monitor maintenance data, display any of the following data and update changes continuously
 - Diversity

The functions above are normally used for maintenance.

44.3.14 Transceiver

The following user functions, related to the transceivers, are available in the OMT:

- Switch on QIU, switch on subjective speech quality improvements uplink for one or more traffic channels within one transceiver¹⁾
- Switch off QIU¹⁾
 - ¹⁾ Facilitates BER measurements according to /GSM:11.20/ and /GSM:05.05/.
- Monitor maintenance data, display any of the following data and update changes continuously
 - Transmission and reception
 - Timing advance
- Switch on Measurement Reports, switch on Measurement Reports for one or several time slots.
- Switch off Measurement Reports, switch off Measurement Reports for one or several time slots.

The functions above are normally used during

- maintenance (switch on/off QIU, Monitor maintenance data)
- installation (switch on/off Measurement Reports)

44.3.15 Managed Object

The following user functions, related to the MOs, are available in the OMT:

- Display state, display the current state of the selected MO
- Display relation, display which Main RU the selected MO is executing on
- Display channel combination, display the channel combination of MO Timeslot

The functions above are normally used for maintenance.

44.3.16 Replaceable Unit

The following user functions, related to the RUs in general, are available in the OMT:

- Display RU info, display any of the following parameters associated with a specific RU
 - RU instance
 - TEI
 - Product number
 - Hardware revision
 - Serial number
 - Position (cabinet, rack, shelf, slot)
 - Logical RU identifier
 - Free text comment
- Define RU HW info, define any of the following parameters associated with a passive RU
 - Product number
 - Hardware revision
 - Serial number
 - Free text comment
- Display RU software revision, for a specific Main RU, display the revision for the following software
 - Currently executing software
 - Base application software stored in non-volatile memory
 - Normal application software in non-volatile memory
- Define RU, define the following parameter associated with the CMRU
 - TEI

The functions above are normally used for

- Maintenance (display RU software revision, display RU HW info)
- Installation (define RU)

44.3.17 Faults

The following user functions, related to fault information, are available in the OMT:

- Monitor current fault status, read the fault status from the RBS and display changes continuously.
- Display fault info, display the current fault information for a specific object such as an RU or a PCM line.

The functions above are normally used at

- Site acceptance (monitor current fault status)
- Maintenance (display fault info)

44.3.18 Remote OMT

A connection between the RBS and a remotely connected OMT can be established. The remote OMT is placed at a BSC site.

The Remote OMT and the locally connected OMT are not interchangeable with each other. They are two separate products performing the same functions.

All functions available in a locally connected OMT are also available in a remotely connected OMT.

The function can fail due to software incompatibility, if no RBS confirms the connection attempt or if an OMT already is connected (locally or remotely). In these cases the operator is informed about the failure. No further action is taken due to the failed connection.

The connection between the RBS and a remotely connected OMT is established on one PCM timeslot and the maximum transmission rate is 64 kbps.

44.4 Operational Conditions

The transmission rate between the OMT and the RBS is 19200 bit/s. The IDB transfer time (between the OMT and the RBS) is specified within the context of Installation Data Handling.

45 External Alarms

45.1 References

Whenever a reference is made to a function described in another chapter, please refer to the table of contents to find the appropriate chapter.

45.2 Concepts

| | |
|---------------------|---|
| External Alarm | An alarm that originates from a source defined by the customer. The alarm is reported over A-bis transparently through the RBS. An example is a fire alarm. |
| Auxiliary Faults | Detected by supervision of auxiliary equipment. |
| Auxiliary Equipment | Equipment connected to the RBS but normally situated outside the RBS cabinet. |
| Alarm Inlet | The binary inlet to which the supervised equipment is connected. Used for both Auxiliary Faults and External Alarms. |
| Alarm Setup | The parameter definition for the alarm inlets, which is set by OMT. |
| Basic Character Set | A subset of the CCITT International Alphabet No 5, International Reference Version. See the table below: |

Table 113 Basic Character set

| Character | Code |
|-------------------------------|---------------------------------------|
| Space | 20 _{hex} |
| 0 1 2 3 4 5 6 7 8 9 | 30 _{hex} - 39 _{hex} |
| : ; < = > ? @ | 3A _{hex} - 40 _{hex} |
| A B C D E F G H I J K L M N O | 41 _{hex} - 4F _{hex} |
| P Q R S T U V W X Y Z | 50 _{hex} - 5A _{hex} |
| - | 5F _{hex} |

45.3 Function

Purpose

This function facilitates external alarms reported via the RBS. Example of this is "fire alarm".

Each active alarm will activate one common indicator light, which will be deactivated when there is no alarm active.

Preconditions and initiation

The external alarms function is started by the restart and recovery function.

Description

The following parameters are associated with each supervised external alarm:

| | |
|---------------------------|--|
| Inlet Number | 1–16. Defines which inlet the external alarm source equipment is connected to. |
| Inlet Usage | "Auxiliary Fault", "External Alarm" or "Not Defined". The default alarm setup is that alarm inlets are "Not Defined". |
| Alarm Identity | The numeric identity of a specific external alarm within the RBS. |
| Alarm Severity | There are two possible severity classifications, "Level 1" or "Level 2". The classification of a specific external alarm is fixed when defining the external alarm. How to handle a severity level is customer-defined. |
| Alarm Data | An alphanumeric string which is presented to the operator when the external alarm is raised. The basic character set, that is presented in Concepts, should be used. The alphanumeric string associated with each external alarm may contain a maximum of 62 characters. |
| Fault Activation Criteria | The way in which the external alarm is activated, either by breaking or closing the circuit on the external alarm inlet. |

The RBS supervises each configured external alarm. An external alarm is filtered, i.e. must remain in a state for a fixed period of time (approximately 3 seconds) before the BSC is notified of the external alarm raising or termination.

The raising or termination of each external alarm is reported to the BSC with the associated Alarm identity, Alarm severity and Alarm data.

To determine which external alarms are raised, the BSC can request this information from the RBS via A-bis.

45.4 Operation and Maintenance

Purpose

Maintenance functions related to external alarms are described within the context of Operation and Maintenance Terminal.

The visual indicators relevant to external alarms are described within the context of Operation and Maintenance Support.

Capabilities

The Capabilities of the different Radio Base Stations are shown in the table below:

Table 114 Maximum number of external alarms defined by the customer

| Radio Base Station | RBS 2301 | RBS 2302 | RBS 2401 |
|----------------------|----------|-----------------|----------|
| External Alarms max. | 4 | 8 ¹⁾ | 0 |

¹⁾ In case of three cascaded RBS 2302, the maximum number of External Alarms is 16.

This page is intentionally left blank

46 Handling of Auxiliary Equipment

A number of customer defined, antenna related auxiliary equipment can be supervised by the RBS. The raising of an auxiliary fault is, after analysis in the RBS, reported to the BSC. Depending on what severity the operator has defined for the fault, the concerned MO could be taken out of operation.

46.1 References

Whenever a reference is made to a function described in another chapter, please refer to the table of contents to find the appropriate chapter.

46.2 Concepts

| | |
|---------------------|--|
| Auxiliary Equipment | Equipment connected to the RBS but normally situated outside the RBS cabinet. |
| ARAE | Antenna Related Auxiliary Equipment. |
| Auxiliary Faults | Detected by supervision of auxiliary equipment. |
| External Alarms | Binary alarms that are reported over Abis transparently through the RBS. An example is fire alarm. |
| Alarm Inlet | The binary inlet to which the supervised equipment is connected. Used for both Auxiliary Faults and External Alarms. |
| Alarm Setup | The parameter definition for the alarm inlets, which is set by OMT. |

46.3 Function

The following ARAE supervision parameters are associated with each auxiliary fault:

| | |
|--|---|
| Inlet number | 1–8. Defines which inlet the Auxiliary Equipment is connected to. |
| Inlet usage | "Auxiliary Fault", "External Alarm" or "Not defined". The default alarm setup is that all alarm inlets are "Not Defined", which means that they have no effect on fault reports for auxiliary equipment, external alarms or fault indicators. |
| Fault activation criteria | Either closing or breaking the sensor loop. |
| If inlet usage is set as "Auxiliary Fault", the following fault information parameters are also set: | |
| Affected functionality | RX and/or TX |

47 Power Supply

The Power System rectifies the incoming power supply to DC voltage for the users in the RBS. The internal DC power is converted centrally with several internal DC voltage levels.

Distribution of system voltage is possible if the DC/DC conversion is distributed.

Since the RBS is designed to apply to different national power systems, there will be a number of connection possibilities to achieve suitable mains power for the RBS.

Battery backup is internal.

47.1 References

Whenever a reference is made to a function described in another chapter, please refer to the table of contents to find the appropriate chapter.

47.2 Concepts

| | |
|------------------|---|
| IT power system | A power distribution system having no direct connection to earth. The exposed conductive parts of the electrical installation are earthed. |
| TN power system | A power distribution system having one point directly earthed. The exposed conductive parts of the installation are connected to that point by protective earth conductors. |
| TT power system | A power distribution system having one point directly earthed. The exposed conductive parts of the installation are connected to earth electrodes electrically independent of the earth electrodes of the power system. |
| Hold-up | The ability to hold the DC output voltage within the allowed range on AC mains interruption, without batteries |
| RBS power system | The function within the RBS that provides the users with power. This comprises the following equipment: rectifiers, batteries, battery fuses, power distribution (cables and so forth) and the power control logic. |
| User | In this document, any unit that needs power from the RBS power system in order to function. |

47.3 Functions

47.3.1 Central AC-DC Conversion

The incoming AC mains is converted by the Cabinet power system to several DC voltages adapted to the users need.

To get the required AC power for the Cabinet, the Cabinet power system can be connected to the following alternative AC mains:

- Single-phase (2-wire; earthed end of phase), TN and TT power systems
- Single-phase (3-wire; earthed mid point), TN and TT power systems
- Single-phase (2-wire; impedance grounded (earthed) neutral, IT power system

TN, TT and IT power systems according to IEC 950.

47.3.2 DC Power Distribution

The users are disconnected from the DC power in cases of low system voltage. The users are reconnected to the DC power when the system voltage is restored.

The units for control and supervision of the Cabinet power system are powered independently of user disconnection.

The DC power is produced and distributed in different modes:

- Produced from incoming power and distributed
- Produced from backup batteries and distributed
- No distribution

47.4 Operational Conditions

47.4.1 Operation and Maintenance

Maintenance functions related to Power Supply are described in chapter Operation and Maintenance Terminal.

47.4.2 Capabilities

Central AC-DC Conversion

Table 116 Electrical data at 50 Hz

| | | |
|--|--|-------------------|
| AC input single-phase voltage: (2-wire; earthed end of phase) (2-wire; impedance grounded (earthed) neutral) | Nominal | 200 V- 250 V |
| | Tolerance | ±10% |
| | Non-destruction range: (phase voltage) | |
| | Permanent | 0 V- 280 V |
| | Overvoltage < 10 ms | 280 V- 300 V |
| AC input frequency | Nominal | 50 Hz |
| | Tolerance | ±10% |
| AC input current | Inrush current (total, all phases) | Cabinet dependent |
| | Short circuit current | Cabinet dependent |

Table 117 Electrical data at 60 Hz

| | | |
|---|--|----------------------|
| AC input single-phase voltage: (2-wire; earthed end of phase) | Nominal | 100 V - 127 V |
| | Tolerance | ±10% |
| | Non-destruction range: (phase voltage) | |
| | Permanent | 0 V - 140 V |
| | Overvoltage < 10 ms | 140 V - 150 V |
| AC input single-phase voltage: (3-wire; earthed mid-point) | Nominal (line voltage/phase voltage) | 200/100 V- 240/120 V |
| | Tolerance | ±10% |
| | Non-destruction range: (line voltage) | |
| | Permanent | 0 V - 270 V |
| | Overvoltage < 10 ms | 270 V - 300 V |
| AC input frequency | Nominal | 60 Hz |
| | Tolerance | ±8% |
| AC input current | Inrush current (total, all phases) | Cabinet dependent |
| | Short circuit current | Cabinet dependent |

Battery backup

See chapter Site Configurations, RBS 2000 Micro.

48 Climate Protection

The "Climate Protection" function:

- Supervises and maintains the internal temperature within allowed ranges for the units in the RBS
- Controls the connection and disconnection of power, at start (or restart) of the RBS and at extreme internal temperature.

The external temperature range for each RBS type is product-specific. To get a complete picture of the climate protection system's capacity, this document should be read in conjunction with the relevant product specification.

The Climate Protection of an RBS can be maintained with one or a combination of the functions described in this chapter.

48.1 Concepts

| | |
|---|--|
| External | Outside the RBS cabinet. |
| Internal | Inside the RBS cabinet. |
| Normal range | Is internal temperature within +5°C to +70°C. |
| Safe range | Is internal temperature range which guarantees full function of the most temperature sensitive internal equipment. |
| Normal operation | Is internal temperature range which is 5°C to 10°C within safe range in both high and low limits. |
| Specified external Normal Condition range | Are stated in relevant product chapter. |
| Normal Condition, safe function and non-destruction | Are defined within the context of Environmental Capability. |
| User | In this chapter, any unit that needs power from the RBS power system in order to function. |

48.2 Functions

48.2.1 Cooling by Natural Convection

Operational Conditions

This function is available when the external temperature is below safe function high level and above 0°C.

Description

This function will maintain the internal temperature by natural convection between the cabinet surface and the external environment.

48.2.2 Climate Supervision

The internal temperature in the RBS is measured by sensors.

The following parameters are measured:

- The internal temperature outside the normal operation.
- The internal temperature outside the safe range.

48.2.3 Heating by Heat Conduction and Radiation

Operational Conditions

This function is available down to an external temperature corresponding to the normal condition low limit.

Description

This heating function works with a heating element placed inside the RBS. The heating function controls the internal temperature to above the normal operation low limit.

48.2.4 Reliability

The cooling Climate Protection is available when the temperature is within the specified external normal condition range. Alarm reporting is available within the safe range.

The Heating function is available when the temperature is above the specified external normal condition low limit and up to normal operation low limit. Alarm reporting is available within the safe range.

48.2.5 Power Connection

At start and restart of the RBS, the connection of the RBS power system to the incoming AC mains and the connection of the users to the DC power in the RBS depends on the current internal temperature.

There are a number of start-up scenarios, based on the internal temperature at the moment of startup:

- The internal temperature is within the safe range.
 - The RBS power system and the user are connected.
- The internal temperature is below the lower limit for safe function.
 - The internal temperature is increased by heating to above the lower limit for safe. Then the power system and the users are connected.
- The internal temperature is above the upper limit for safe function.

- The RBS power system is connected but the users are not. However, as soon as the internal temperature falls below the upper limit for safe function, the users are connected.

48.2.6 Power Disconnection and Reconnection

The users are disconnected from the DC power when the internal temperature is outside the safe range.

When the internal temperature has returned back within the safe range, the users are reconnected to the DC power.

This page is intentionally left blank

49 Transmission Interface Handling G.703 2048 kbit/s

This function specification covers RBS functions for layer 1 communications on A-bis.

The function Layer 1 Termination terminates a 2048 kbit/s G.703 PCM line.

The function Supervision of Transmission faults detects faults in the transmission interface.

The function Supervision of Transmission Quality monitors the quality of the transmission.

49.1 References

/GSM 08.54/ GSM Technical Specification 08.54

All ITU-T references refer to the White Book (ITU = International Telecommunications Union).

49.2 Concepts

Timeslot 0 (TS0) The content and structure of timeslot 0 is described in the table below. This figure is included to ease the understanding of the functions Layer 1 Termination and Supervision of Transmission Faults.

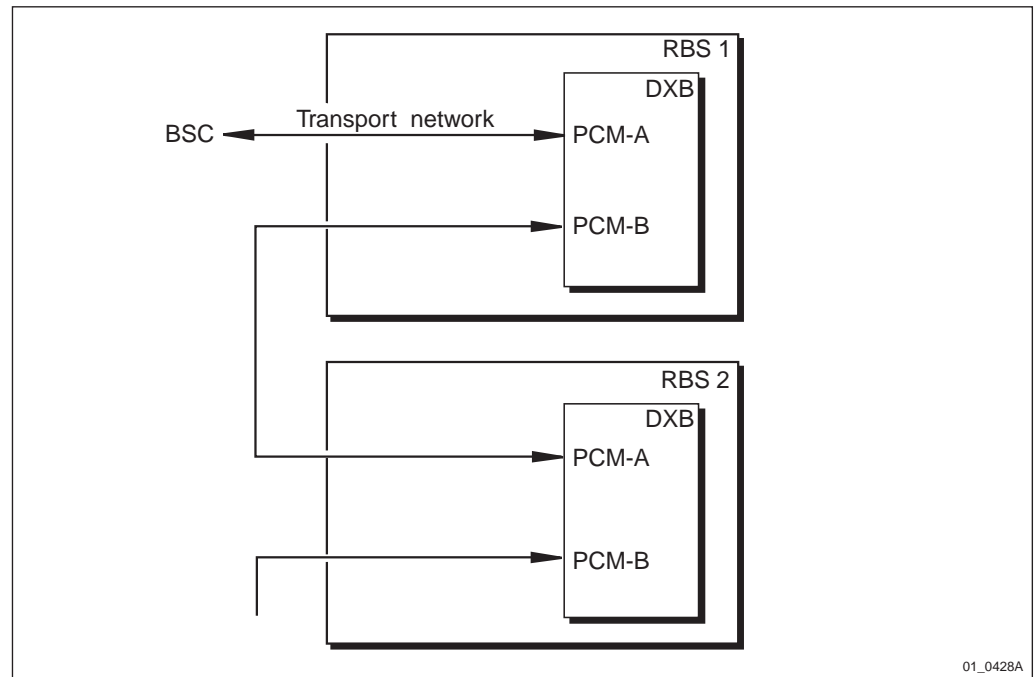

01_0428A

Figure 96 Upstream and Downstream

CMRU Central Main Replaceable Unit. An RBS has exactly one CMRU. In the RBS 2000 hardware architecture the Distribution Switch is the CMRU.

For further information, see ITU-T G.704 White Book.

49.3 Functions

49.3.1 Layer 1 Termination 2048 kbit/s, 75 Ohm

The function is initiated during restart of CMRU.

Layer 1 termination of the transport network interface is handled according to /GSM:08.54:4.0.0/. This includes:

- Physical and electrical characteristics according to ITU-T rec. G.703 (interface at 2048 kbit/s, 75 ohm and over-voltage protection according to Annex B)
- Frame structure according to ITU-T rec. G.704 section 2.3 (includes handling of the E-bit in timeslot 0)
- Frame alignment and CRC-4 procedures according to ITU-T rec. G.706 section 4
- Synchronization of layer 1 handling is described in Section 49.3.3 on page 400.
- Detection of fault conditions, alarm states, and consequent actions. This includes detection of:
 - LOS (Loss Of Signal)
 - LOF (Loss Of Frame alignment)

- ERATE (Error RATE)
- AIS (Alarm Indication Signal)
- RAI (Remote Alarm Indication)

The consequent actions are transmission of:

- Alarm indication to the remote end (A-bit in time slot 0 equal to "1")
- CRC-4 error indicator (E-bit in time slot 0 equal to "0")

Both actions are according to ITU-T recommendations G.704 and G.732.

- Transmission of spare bits (Sa4-Sa8). The spare bits form a fixed bit pattern (see section Section 49.4.1 Operation and Maintenance on page 407)

Two PCM paths are supported: PCM-A and PCM-B. However, PCM-B can only be used when the function Multidrop (see chapter Channel Distribution Function) is activated.

49.3.2 Layer 1 Termination with Long Haul Performance, 2048 kbit/s, 120 Ohm

Long Haul is available from the Ericsson GSM system R6.1. Long Haul is initiated during restart of the CMRU.

The function is handled according to Section 49.3.1 on page 399, except for the receiver sensitivity and cable type.

Long Haul makes it possible to use longer cables for transmission.

The Long Haul functionality is accomplished by high sensitivity in the receiver.

The receiver dynamic range is from 0 down to –30 dB at 1024 kHz for 120 ohms twisted pair cables (0 dB = 6.0 Vp-p). To cope with noise, a margin should be used for the receiver dynamic range. The maximum cable length is calculated as:

Max. cable length = Receiver sensitivity/(Cable attenuation per metre).

To take advantage of the Long Haul function the Far End, for example a DXX, Mini DXC, BSC, or another RBS must support Long Haul.

Two PCM paths are supported: PCM-A and PCM-B. If only one port is connected to the transport network, that one has to be PCM-A.

49.3.3 Layer 1 Synchronization

Synchronization of layer 1 is either derived from PCM A or taken from a free running oscillator. If PCM-A is in one of the alarm states

- LOF (Loss Of Frame), or
- LOS (Loss Of Signal)
- AIS (Alarm Indication Signal)

it cannot be used as reference source.

The synchronization of layer 1 is in one of two states:

1. PCM-A can be used as reference source.

PCM-A is selected as the reference source.

PCM-A incoming is used to synchronize PCM-A outgoing.

PCM-A incoming is used to synchronize PCM-B outgoing.

2. PCM-A cannot be used as reference source.

The free running oscillator is selected as reference source.

The free running oscillator is used to synchronize both PCM-A and B outgoing.

49.3.4 Supervision of Transmission Faults

The function is initiated during restart of DXU.

The configuration of fault supervision can only be performed when the AO DP (Digital Path) is in state "Disable". The reporting to the BSC is performed when the AO DP is in state "Enable". When the AO DP is enabled, all fault supervision states are set to zero.

Reports are sent to the BSC when the alarm status is changed or when the BSC requires it.

Fault supervision of the PCM line is performed according to /ITU-T rec. G.732 section 4/ and /GSM:08.54:4.0.0/.

This includes detection of the following fault conditions:

- LOF (Loss of Frame Alignment)
- CSES (Consecutive Severely Errored Seconds) or excessive bit ERATE (Error RATE)
- LOS (Loss Of incoming Signal)
- AIS (Alarm Indication Signal)
- RAI (Remote Alarm Indication)
- UAST (UnAvailable STate supervision)

Fault handling is according to Diagnostic and Fault Handling functionality.

LOF Commences

CRC-4 is OFF: Three consecutive frame alignment signals in TS0 received with an error.

CRC-4 is ON: CRC multiframe alignment has not been achieved within a search time of 500 ms or three consecutive frame alignment signals in TS0 received with an error or CRC multiframe alignment is lost during monitoring for incorrect frame alignment (≥ 915 errored CRC blocks out of 1000).

LOF Ceases

CRC-4 is OFF: Recovery of frame alignment signal.

CRC-4 is ON: Recovery of CRC multiframe alignment signal.

CSES Commences

More than N SES (Severely Errored Seconds) detected consecutively. The criteria for SES are described in Section Severely Errored Seconds Supervision on page 405.

This condition is set instead of ERATE when quality supervision including CRC-4 is used.

CSES Ceases

More than N non-SES detected consecutively.

ERATE Commences

Detection of bit error ratio equal to or more than 10^{-3} .

The frame alignment word in time slot 0 even frames is used to determine the error rate.

ERATE Ceases

Detection of bit error ratio less than 10^{-3} .

LOS Commences

Three or less 1s are received in a time interval of 250 μ s.

LOS Ceases

More than three 1s are received in a time interval of 250 μ s.

AIS Commences

A continuous stream of 1s during two frames. A limited number of 0s corresponding to $BER = 10^{-3}$ is allowed.

AIS Ceases

Frame alignment signal is detected or recognised.

RAI Commences

The A-bit (in timeslot 0) = 1.

RAI Ceases

The A-bit (in timeslot 0) = 0.

UAST Commences

UAST commences when unavailable state is declared. Each direction (upstream and downstream) is supervised independently of the other.

An unavailable state for one direction is declared at the onset of P consecutive SES for the direction of interest. These P seconds are considered to be part of the unavailable time.

Together with the alarm status, time information for each direction of UAST is reported to the BSC. When UAST commences, zero is reported as time information. When UAST ceases, the time that the UAST alarm has been activated is reported.

When the BSC requests the alarm status, two scenarios are possible: UAST is activated and UAST is not activated. If it is activated, zero is reported as time information. Otherwise, the time that the UAST alarm was activated the latest time, is reported to the BSC.

UAST Ceases

UAST ceases when available state is declared. Each direction (upstream and downstream) is supervised independently of the other.

A new period of available state begins at the onset of Q consecutive seconds with no SES detected. These Q seconds are considered to be part of the available time.

49.3.5 Supervision of Transmission Quality

The function is initiated when the AO DP is enabled from the BSC.

The configuration of quality supervision can only be performed when the AO DP is in state "Disable". The reporting to the BSC is performed when the AO DP is in state "Enable".

Quality supervision consists of six supervision functions:

- BFF (Bit Fault Frequency)
- DF (Disturbance Frequency)
- SF (Slip Frequency)
- ES (Errored Seconds)
- SES (Severely Errored Seconds)
- UAS (Unavailable Seconds)

Bit Fault Frequency Supervision

The frame alignment word in time slot 0 in even frames is used to determine an error rate. The actual error rate is established by taking the number of faulty frame alignment words and dividing them by the total number of checked bits during the BI (Base Interval).

The bit fault frequency is supervised and reported as the mean bit error ratio in ppm (parts per million) during the BI.

Disturbance Frequency Supervision

This supervision monitors the detected fault situations which are regarded as disturbances upon detection. Upon detection the following events are regarded as disturbances:

- LOF (Loss Of Frame) alignment
- LOS (Loss Of Signal)
- AIS (Alarm Indication Signal)

- RAI (Remote Alarm Indication) received from remote end

Two disturbance frequency counters exist. Both are derived from the downstream PCM port, but one is closely connected to downstream faults while the other one is related to upstream faults.

The DF downstream counter is incremented by 1 for each occurrence of

- LOF or
- LOS or
- AIS

The DF upstream counter is incremented by 1 for each occurrence of RAI.

Every detected fault situation is registered and regarded as a disturbance, even if it does not last long enough to be recognised as a fault.

The DF is supervised and reported as the number of disturbances during the BI. Both counters are handled separately.

Slip Frequency Supervision

This supervision monitors the number of slips per time interval. A slip is defined as where one frame (256 bits) is either lost or duplicated.

The SF counter is incremented by one for each slip on the PCM port downstream.

The SF is supervised and reported as the number of slips during the BI.

Errored Seconds Supervision

An ES is a second with at least one of the following events:

- CRC-4 is OFF: At least one frame bit error
- CRC-4 is ON: At least one CRC-4 error
- LOF alignment
- LOS
- Slip
- AIS
- A-bit equal to "1" from the remote end
- E-bit indication received from the remote end (only valid when CRC-4 is used)

Two counters for errored seconds exist. Both are derived from the downstream PCM port, but one is closely connected to downstream faults while the other one is related to upstream faults.

The downstream counter is incremented by 1 for each second with at least one of the events:

- CRC-4 error (only valid when CRC-4 is used) or
- Frame bit error (only valid when CRC-4 is not used) or
- LOF or

- LOS or
- AIS or
- Slip

The upstream counter is incremented by 1 for each second with at least one of the events:

- A-bit="1" or
- E-bit="0" (only valid when CRC-4 is used)

ES are not counted during unavailable state.

Both ES counters are reported after each BI.

Severely Errored Seconds Supervision

An SES is a second with at least one of the events:

- CRC-4 is OFF: At least N4 frame bit errors
- CRC-4 is ON: At least N1 CRC-4 errors
- LOF alignment
- LOS
- AIS
- A-bit equal to "1" from the remote end
- N1 E-bit indication received from the remote end (only valid when CRC-4 is used)

Two counters for severely errored seconds exist. Both are derived from the downstream PCM port, but one is closely connected to downstream faults while the other one is related to upstream faults.

The downstream counter is incremented by 1 for each second with at least one of the following events:

- N1 CRC-4 errors (only valid when CRC-4 is used) or
- N4 frame bit errors (only valid when CRC-4 is not used) or
- 1 LOF or
- 1 LOS or
- 1 AIS

The upstream counter is incremented by 1 for each second with at least one of the following events:

- 1 A-bit="1" or
- N1 E-bit="0" (only valid when CRC-4 is used)

SES are not counted during unavailable state.

Both SES counters are reported after each BI.

UAS and Unavailable State Supervision

UAS is a count of one-second intervals during which service is unavailable. This period of time is referred to as the unavailable state.

The two directions (upstream and downstream) are supervised separately. That is, one of the directions can be in the unavailable state but the other is in the available state.

The counting of ES and SES is stopped for both directions as soon as at least one of the directions is in the unavailable state.

An unavailable state for one direction is declared at the onset of P consecutive SES for the direction of interest. These P seconds are considered to be part of the unavailable time. A new period of available state begins at the onset of Q consecutive seconds with no SES detected. These Q seconds are considered to be part of the available time.

The number of unavailable seconds for each direction is reported after each BI.

49.3.6 Administration

Supervision of transmission faults and transmission quality can be performed in different ways. With the help of parameters, the supervision can be configured to meet a wide range of requirements. The configuration parameters can only be changed when the AO DP is in state "Disable". The parameters of interest are given below:

- The configuration parameter N
 - Defines the threshold number (SES) for commence, and cease, of CSES
 - Value range is 5-60
 - Default value is 10
- The parameters P and Q
 - Used for defining unavailable state
 - Value range is 5-15 s
 - Default value is 10 s
- The parameters N1 and N4
 - Define the threshold numbers for ES and SES. Value range and default values are listed below:

Table 119 Parameters N1-N4

| Parameter | Value | Range | Description (number of...) |
|-----------|-------|--------|--|
| N1 | 805 | 1-1000 | CRC-4 errors for SES and E-bits equal to "0" |
| N2 | - | | Not used |
| N3 | - | | Not used |
| N4 | 28 | 1-100 | Frame errors for SES |

- The configuration parameter T

- The parameter T defines the time interval for ERATE supervision
- Value range is 1-5 s
- Default value is 2 s
- The configuration parameter AFT
 - The configuration parameter AFT defines the Alarm Filtering Time for all the fault supervision functions
 - Value range is 50-5000 ms
 - Default value is 125 ms
 - The resolution is 1 ms, but the accuracy is ± 25 ms
- Base interval for ES, SES, UAS, BFF and SF
 - Valid values: 60 and 80 s
- Base interval for DF and SF
 - Value range: 1-24 h

49.3.7 Multidrop Layer 1

Multidrop is available from the Ericsson GSM system R6.1.

For an RBS configured for multidrop, the function is initiated during restart of CMRU.

For an RBS not configured for multidrop, the function is initiated when the parameter Network Topology is set by the OMT to indicate multidrop (cascade).

AIS Generation

- When entering one of the alarm states LOF, LOS or AIS at PCM-A input, AIS is transmitted on PCM-B output. AIS is transmitted until the alarm state is left.
- When entering and leaving alarm states, the alarm filtering time is used (AFT).

49.4 Operational Conditions

49.4.1 Operation and Maintenance

Maintenance data such as CRC-4 status and the values of the spare bits in timeslot 0 can be set by the OMT. The OMT part is described in chapter Operation and Maintenance Terminal.

The values of the spare bits in timeslot 0 can also be set by the BSC. The BSC can set the data when the AO DP is in state "Disable". The new settings will take effect next time the AO DP is enabled. The IDB is not updated if a new setting is ordered from the BSC.

This page is intentionally left blank

50 Transmission Interface Handling DS1 1544 kbit/s

This function specification covers RBS functions for layer 1 communications on A-bis.

The function Layer 1 Termination terminates a 1544 kbit/s DS1 PCM line.

The function Supervision of Transmission faults detects faults in the transmission interface.

The function Supervision of Transmission Quality monitors the quality of the transmission.

50.1 References

Transmission references:

- ANSI T1.102–1993
- ANSI T1.403-1989
- AT&T T1.5 Service (TR 62411) Dec. 1990
- Bellcore TR-NWT-000499 Apr. 1992

50.2 Concepts

| | |
|--|--|
| ESF | Extended Superframe Format. The content and structure of the F-bit is described in Table 120 on page 410. This table is included to ease the understanding of the functions: Layer 1 Termination, and Supervision of Transmission Faults. |
| RBS Operational State Not Ready For Operation | When in state "Not Ready For Operation", the RBS is neither prepared for BSC communication nor for local operation. |

Table 120 Extended Superframe Format (ESF)

| Frame number | F bits | | | | Bit use in each timeslot | | Signalling bit use options | | | |
|--------------|------------|-----|----|-----|--------------------------|---------------------|----------------------------|---|---|----|
| | Bit number | FPS | DL | CRC | Traffic ¹⁾ | Sign. ¹⁾ | T ¹⁾ | 2 | 4 | 16 |
| 1 | 0 | - | m | - | 1 - 8 | - | - | - | - | - |
| 2 | 193 | - | - | C1 | 1 - 8 | - | - | - | - | - |
| 3 | 386 | - | m | - | 1 - 8 | - | - | - | - | - |
| 4 | 579 | 0 | - | - | 1 - 8 | - | - | - | - | - |
| 5 | 772 | - | m | - | 1 - 8 | - | - | - | - | - |
| 6 | 965 | - | - | C2 | 1 - 7 | 8 | - | A | A | A |
| 7 | 1158 | - | m | - | 1 - 8 | - | - | - | - | - |
| 8 | 1351 | 0 | - | - | 1 - 8 | - | - | - | - | - |
| 9 | 1544 | - | m | - | 1 - 8 | - | - | - | - | - |
| 10 | 1737 | - | - | C3 | 1 - 8 | - | - | - | - | - |
| 11 | 1930 | - | m | - | 1 - 8 | - | - | - | - | - |
| 12 | 2123 | 1 | - | - | 1 - 7 | 8 | - | A | B | B |
| 13 | 2316 | - | m | - | 1 - 8 | - | - | - | - | - |
| 14 | 2509 | - | - | C4 | 1 - 8 | - | - | - | - | - |
| 15 | 2702 | - | m | - | 1 - 8 | - | - | - | - | - |
| 16 | 2895 | 0 | - | - | 1 - 8 | - | - | - | - | - |
| 17 | 3088 | - | m | - | 1 - 8 | - | - | - | - | - |
| 18 | 3281 | - | - | C5 | 1 - 7 | 8 | - | A | A | C |
| 19 | 3474 | - | m | - | 1 - 8 | - | - | - | - | - |
| 20 | 3667 | 1 | - | - | 1 - 8 | - | - | - | - | - |
| 21 | 3860 | - | m | - | 1 - 8 | - | - | - | - | - |
| 22 | 4053 | - | - | C6 | 1 - 8 | - | - | - | - | - |
| 23 | 4246 | - | m | - | 1 - 8 | - | - | - | - | - |
| 24 | 4439 | 1 | - | - | 1 - 7 | 8 | - | A | B | D |

¹⁾ No channel associated signalling, only T-column applicable. 8 traffic bits in every frame.

| | |
|-------------------------|--|
| Frame 1 | Transmitted first |
| Frames 6, 12, 18 and 24 | Denoted signalling frames |
| FPS | Framing Pattern Sequence (...001011...) |
| DL | 4 kbit/s Data Link (Message bits m) |
| CRC | CRC-6 Cyclic Redundancy Check (Bits C1-C6) |
| Option T | Traffic (Bit 8 not used for Robbed-bit signalling) |
| Option 2 | 2-State Signalling (Channel A) |
| Option 4 | 4-State Signalling (Channel A and B) |
| Option 16 | 16-State Signalling (Channel A, B, C and D) |

| | |
|----------------------|--|
| Downstream | The path for information from the BSC to the MS. |
| Upstream | The path for information from the MS to the BSC. |
| Linear Cascade Chain | A cascade of RBS:s according to Figure 97 on page 411. |

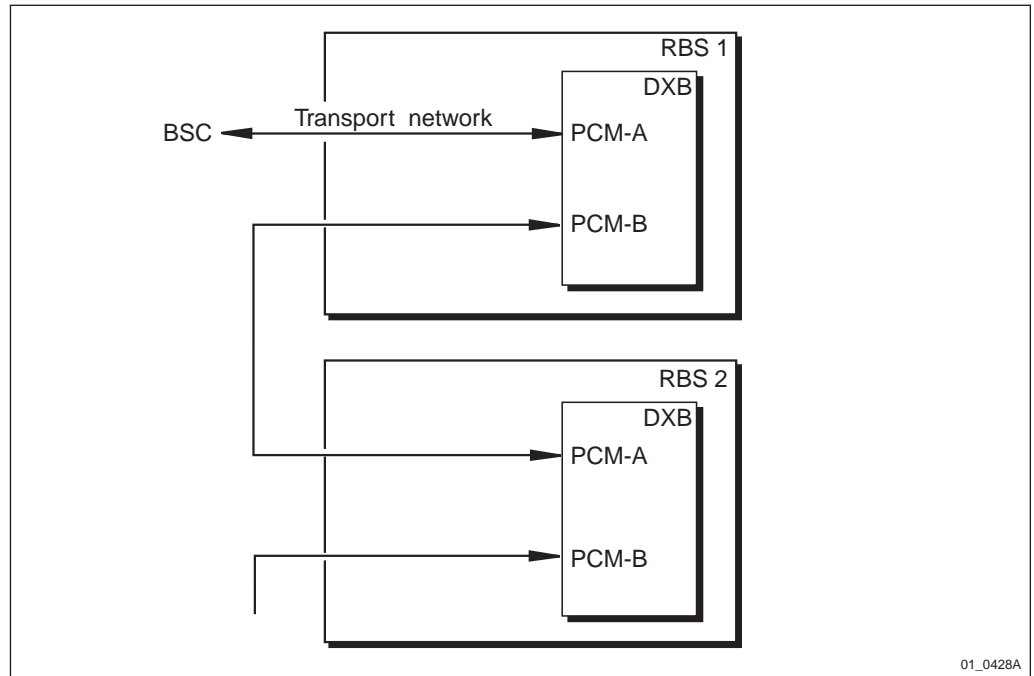

Figure 97 Two RBSs in a linear cascade chain

| | |
|------|--|
| CMRU | Central Main Replaceable Unit. An RBS has exactly one CMRU. In the RBS 2000 hardware architecture the Distribution Switch is the CMRU. |
|------|--|

50.3 Functions

50.3.1 Long Haul DS1

Purpose

Long Haul makes it possible to use longer cables for transmission.

Precondition and initiation

Operational condition for initiation: All RBS operational states except RBS not ready for operation.

Long Haul is configured in OMT by using the LBO-parameter. The updated parameter is used directly after the selection of the LBO-parameter is performed.

Description

The Long Haul functionality is accomplished by high sensitivity in the receiver.

The receiver dynamic range is from 0 down to -30 dB at 772 kHz for 100 ohms twisted pair cables (0 dB = 6.0 Vp-p). To cope with noise, a margin should be used for the receiver dynamic range. The maximum cable length is calculated as:

Max. cable length = Receiver sensitivity/(Cable attenuation per metre).

To take advantage of the Long Haul function the Far End, for example a DXX, Mini DXC, BSC, or another RBS, must support Long Haul.

Two PCM paths are supported: PCM-A and PCM-B. If only one PCM port is connected to the transport network, that one has to be PCM-A.

50.3.2 Line Build Out (LBO)

Purpose

There are two purposes for LBO. Some receivers at the Far End may not be able to receive signals higher than -7.5 dB, and the output signal from the RBS must therefore be attenuated. The other purpose is to keep two or more input signals to the equipment at roughly the same signal level in order to minimise Far End cross talk. Some Far End equipment requires that the input signals do not differ more than 7.5 dB.

Precondition and initiation

LBO is only available when using Long Haul.

Operational condition for initiation: All RBS operational states except RBS not ready for operation.

LBO is configured in OMT by using the LBO-parameter. The updated parameter is used directly after the selection of the LBO-parameter is performed.

Description

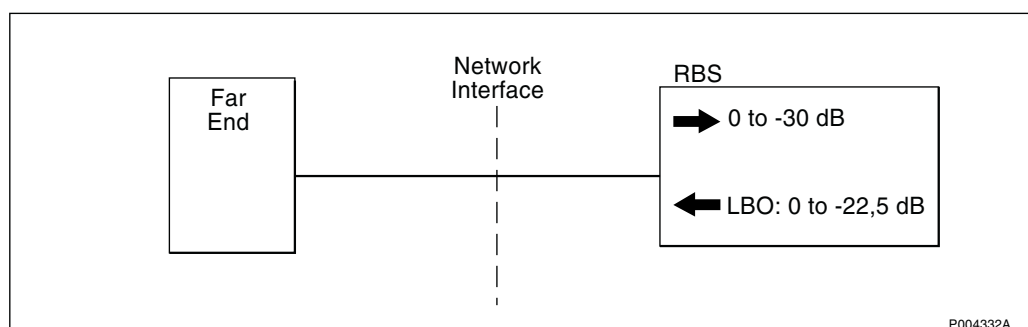

Figure 98 Line Build Out (LBO)

LBO attenuates the output signal from a PCM port. The possible LBO attenuation values are 0 , -7.5 , -15 and -22.5 dB. The LBO simulates Line attenuation so that the Far End can handle the resulting signal correctly. Two PCM paths are supported: PCM-A and PCM-B.

By the OMT the operator can set manual or automatic LBO (ALBO).

Manual LBO for Carrier Advised Code

If the carrier provider has advised a defined signal level, Carrier Advised Code, at the Network Interface (NI), the LBO value set at the RBS depends on the Line attenuation between the RBS and the NI. See the table below.

Table 121 LBO-parameter values in case of Carrier Advised Code (dB)

| Line Attenuation (dB) | Carrier Advise Code, NI (dB) | | | |
|-----------------------|------------------------------|------|------|-------|
| | A | B | C | D |
| | 0 | -7.5 | -15 | -22.5 |
| 0 - 5.5 | 0 | -7.5 | -15 | -22.5 |
| 7.5 - 13 | N/A | 0 | -7.5 | -15 |
| 15 - 20.5 | N/A | N/A | 0 | -7.5 |
| 22.5 - | N/A | N/A | N/A | 0 |

Example: If the carrier provider advises an LBO-code of B, it indicates that the overall attenuation between the RBS and the NI is presumed to be 7.5 to 13 dB. The customer has then the option to position the RBS further from the NI, using the LBO-parameter value 0 dB as long as the Line attenuation is between 7.5 and 13 dB.

Manual LBO for maximum input signal level at the Far End

In order to manually set the LBO attenuation values in the OMT, the operator has to know:

- Maximum input signal level of the equipment at the Far End
- Line attenuation

The Line attenuation is either calculated or measured. The LBO attenuation value is calculated as follows:

Maximum output level = Maximum input signal level at the Far End + Line attenuation. The LBO standard value with the closest higher attenuation is chosen.

Automatic LBO

The input information to the OMT for choosing automatic LBO (ALBO) is the maximum input signal level at the Far End. The default value is 0 dB. The following is automatically performed by the OMT:

- The Line attenuation is calculated by measuring the receiver signal at the PCM port of the RBS. The output signal from the Far End is always assumed to be 0 dB.
- The appropriate standard LBO value is set from the Line attenuation and the maximum input signal level at the Far End.

The Line attenuation value can be seen in OMT2.

LBO with Multidrop

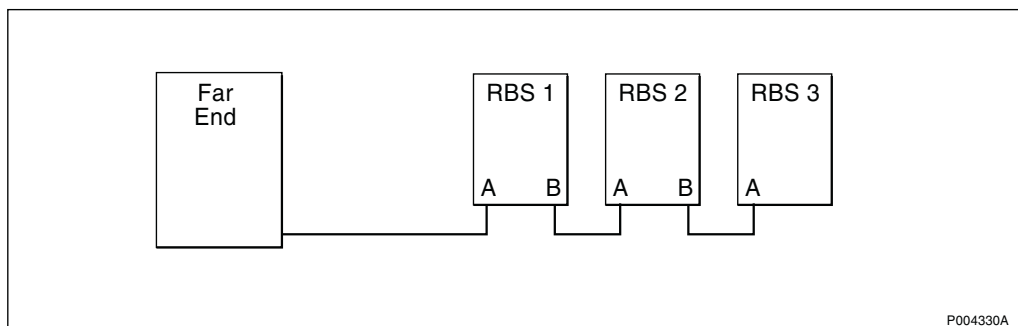

Figure 99 RBS cascade chain

Automatic or manual LBO can be used between the Far End and RBS1 port A as in the Stand Alone case. The LBO at port A in the other RBSs must be set manually.

The LBO-parameter at port A of RBS2 should be set as if RBS1 were in Bypass State.

For Carrier Advised Code at the NI, the total Line attenuation is the line attenuation between the NI and the RBS1 plus the Line attenuation between RBS1 and RBS2.

For a maximum input signal level at the Far End, the total Line attenuation is the Line attenuation between the Far End and the RBS1 plus the Line attenuation between RBS1 and RBS2.

The port A of RBS3 is set as if RBS2 and RBS3 were in Bypass State and so on. The port B outputs will always have 0 dB LBO attenuation for all RBSs.

50.3.3 Short Haul DSX-1

Purpose

The Short Haul functionality is used to reach a signal level of 0 dB at the DSX-1 cross-connect interface described in ANSI T1.102–1993.

Precondition and initiation

Operational condition for initiation: All RBS operational states except RBS not ready for operation.

Short Haul is configured in OMT by using the LBO-parameter. The updated parameter is used directly after the selection of the LBO-parameter is performed.

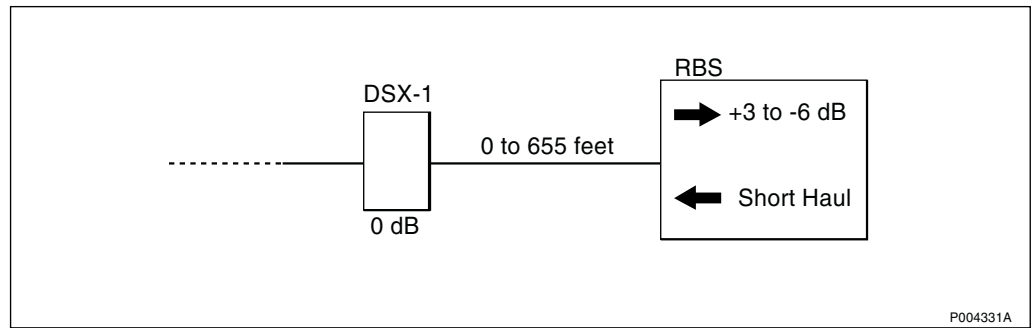
Description*Figure 100 Short Haul DSX-1*

In order to reach 0 dB at the DSX-1 cross-connect interface, the PCM port output signal can be amplified to five different levels. In the OMT, the signal level is chosen according to the cable length between the RBS and the DSX-1 interface. The reference cable is a multi-pair 22 AWG office cable with overall outer shield (22 AWG ABAM).

The following values are supported:

- 0 – 133 feet
- 133 – 266 feet
- 266 – 399 feet
- 399 – 533 feet
- 533 – 655 feet

The receiver dynamic range is +3 to –6 dB (0 dB = 6.0 Vp-p) at 772 kHz for 100 ohms twisted pair cables.

50.3.4 Layer 1 Termination Long Haul 1544 kbit/s

The function is initiated during restart of CMRU.

Layer 1 termination on the transport network interface includes:

- Physical and electrical characteristics according to ANSI T1.403 (interface at 1544 kbit/s, one pair for each direction of transmission, test load impedance 100 Ohm resistive), except the receiver dynamic, see below.
- Frame structure according to ANSI T1.403, ESF. T option only. See Table 120 on page 410.
8 traffic bits in all frames in the ESF.
- Line coding B8ZS according to AT&T T1.107. B8ZS is the only technology to provide 64 kb/s Clear Channel Capacity (64CCC).
- When no message is sent on the Data Link (DL, message bit m in the ESF, an idle pattern (01111110) (ref. ANSI 6.4(2)) is transmitted. The datalink is used for RAI information in both directions. See Table 120 on page 410.
- Frame alignment and CRC–6 procedures according to ANSI T1.403, 24–frame ESF.

- Fault supervision of each PCM path is performed according to:
 - ANSI T1.403 section 9 (1995)
 - AT&T T1.5, paragraph 7

This includes detection of the fault conditions LOF, LOS, ERATE, AIS and RAI. It also includes a consequent action. The consequent action for the faults LOF, LOS, ERATE, AIS and UAST downlink is to send RAI patterns (...1111111100000000...) continuously on the 4 kbit/s link to the remote end. This is performed for at least one second.

Two PCM paths are supported: PCM-A and PCM-B. However PCM-B can only be used when the function Multidrop (see chapter Channel Distribution Function) is activated.

The receiver dynamic range for layer 1 transmission long haul is 0 to -30 dB at 772 kHz (0 dB = 6.0 Vp-p, 100 ohms twisted pair cables).

50.3.5 DS1 Synchronization

Synchronization of layer 1 is derived either from one of the incoming PCM paths or taken from a free running oscillator.

The following cannot be used as a reference source:

- A PCM path with LOF, LOS or AIS.
- A PCM path that is "not available for synchronization" according to RBS DB.

The synchronization of layer 1 is in one of four states:

- Both PCM-A and PCM-B can be used as reference source.
 - PCM-A is selected as the reference source.
 - PCM-A incoming is used to synchronize PCM-A outgoing.
 - PCM-B incoming is used to synchronize PCM-B outgoing.
- PCM-A can be used as reference source, PCM-B cannot.
 - PCM-A is selected as the reference source.
 - PCM-A incoming is used to synchronize PCM-A outgoing.
 - PCM-A incoming is used to synchronize PCM-B outgoing.
- PCM-B can be used as reference source, PCM-A cannot.
 - PCM-B is selected as the reference source.
 - PCM-B incoming is used to synchronize PCM-A outgoing.

- PCM-B incoming is used to synchronize PCM-B outgoing.
- Neither PCM-A nor PCM-B can be used as reference source.
 - The free running oscillator is selected as reference source.
 - The free running oscillator is used to synchronize both PCM-A and PCM-B outgoing.

The default setting is:

- PMC-A: "Available for synchronization"
- PMC-B: "Not available for synchronization"

The parameters can be modified from OMT. The new setting is activated instantly. Thus the updated parameters are used when the synchronization source is selected.

50.3.6 Supervision of Transmission Faults

The supervision is initiated during restart of CMRU.

Fault supervision of each PCM line is performed according to:

- ANSI T1.403, section 8
- AT&T T1.5 SERVICE, paragraph 7

The configuration of fault supervision can only be performed when the AO DP (Digital Path) is in state "Disable". The reporting to the BSC is performed when the AO DP is in state "Enable". When the AO DP is enabled, all fault supervision states are set to zero.

Reports are sent to the BSC when the alarm status is changed or when required from the BSC.

The fault supervision includes detection and reporting of the following fault conditions:

- LOF (Loss of Frame Alignment)
- ERATE (Excessive Error RATE)
- LOS (Loss Of incoming Signal)
- AIS (Alarm Indication Signal), "Blue Alarm"
- RAI (Remote Alarm Indication), "Yellow Alarm"
- UAST (UnAvailable STate supervision). Consists of two directions; upstream and downstream.

Fault handling is according to Diagnostic and Fault Handling functionality.

LOS commences

At least 31 successive pulse positions with no pulses of either positive or negative polarity have occurred.

LOS ceases

Recovery of frame alignment signal.

LOF commences

A LOF condition is declared when any two of five consecutive received framing bits contain bit errors in the framing pattern or when LOS condition is declared.

LOF ceases

Recovery of frame alignment signal.

ERATE commences

An ERATE condition is declared when the bit error rate is equal to or greater than $1 \cdot 10^{-3}$ during time T. The number of CRC-6 errors is used in this evaluation.

ERATE ceases

The ERATE condition ceases when the bit error rate is less than $1 \cdot 10^{-3}$ during time T.

AIS commences

LOF and a continuous received stream of 1's during 24 frames (all-ones) is detected. The "all-ones" are detectable in the presence of a $1 \cdot 10^{-3}$ BER (Bit Error Rate).

AIS ceases

When at least one of the conditions LOF and "all-ones" is cleared.

RAI commences

At least four consecutive 16-bit patterns consisting of eight 1's followed by eight 0's (i.e. 4 times 1111111100000000), is detected over the ESF data link. The signal is detected in less than one second and in the presence of a $1 \cdot 10^{-3}$ BER.

RAI ceases

The RAI signal pattern does not occur in 8 to 13 contiguous 16-bit signal pattern intervals.

UAST commences

UAST commences when unavailable state is declared. Each direction (upstream and downstream) is supervised independently of the other.

Together with the alarm status, time information for each direction of UAST is reported to the BSC. When UAST commences, zero is reported as time information. When UAST ceases, the time that the UAST alarm has been activated is reported.

When the BSC requests the alarm status, two scenarios are possible: UAST is activated and UAST is not activated. If it is activated, zero is reported as time information. Otherwise, the time that the UAST alarm was activated the latest time, is reported to the BSC.

UAST ceases

UAST ceases when available state is declared. Each direction (upstream and downstream) is supervised independently of the other.

50.3.7 Supervision of Transmission Quality

The function is initiated when the AO DP is enabled from the BSC.

The configuration of quality supervision can only be performed when the AO DP is in state "Disable". The reporting to the BSC is performed when the AO DP is in state "Enable".

Quality supervision consists of six supervision functions:

- BFF (Bit Fault Frequency)
- DF (Disturbance Frequency)
- SF (Slip Frequency)
- ES (Errored Seconds)
- SES (Severely Errored Seconds)
- UAS (Unavailable Seconds)

Bit Fault Frequency supervision

The number of bit errors in the received 1544 kbit/s signal is used to establish an error rate. The CRC-6 sequence is used to obtain the number of bit errors. In this method, the distribution of errors in the time is considered. Bursts of faults decrease the number of CRC errors detected compared to what would have been detected with an equal distribution of faults in time.

The probability of bit faults appearing in bursts is greater than the probability of detecting single isolated bit faults. This probability increases with the real bit error rate, and with the length of the time period over which the real bit fault frequency is calculated.

In the used method, the number of CRC-6 errors is counted during the base interval. Then, a translation to bit fault frequency is performed.

The bit fault frequency is supervised and reported as the mean bit error ratio in ppm (parts per million) during the BI (Base Interval).

Disturbance Frequency supervision

This supervision monitors detected fault situations which are regarded as disturbances upon detection. Upon detection the following events are regarded as disturbances:

- LOF (Loss Of Frame) alignment
- LOS (Loss Of Signal)

- AIS (Alarm Indication Signal)
- RAI (Remote Alarm Indication) received from remote end

Two disturbance frequency counters exist. Both are derived from the downstream PCM port, but one is closely connected to downstream faults while the other one is related to upstream faults.

The DF downstream counter is increased by 1 for each occurrence of:

- LOF or
- LOS or
- AIS

The DF upstream counter is increased by 1 for each occurrence of RAI.

Every detected fault situation is registered and regarded as a disturbance, even if it does not last long enough to be recognized as a fault.

The DF is supervised and reported as the number of disturbances during the BI. Both counters are handled separately.

Slip Frequency supervision

This supervision monitors the number of slips per time interval. A slip is defined as where one frame (193 bits) is either lost or duplicated.

The SF counter is increased by one for each slip on the PCM port upstream or on the PCM port downstream.

The SF is supervised and reported as the number of slips during the BI.

Errored Seconds supervision

An ES is a second with at least one of the following events:

- CRC-6 error
- LOF alignment
- LOS
- Slip
- AIS
- RAI

Two counters for errored seconds exist. Both are derived from the downstream PCM port, but one is closely connected to downstream faults while the other one is related to upstream faults.

The downstream counter is increased by 1 for each second with at least one of the events:

- CRC-6 error or
- LOF or
- LOS or
- AIS or
- Slip

The upstream counter is increased by 1 for each second with at least one RAI.

ES are not counted during unavailable state.

Both ES counters are reported after each BI.

Severely Errored Seconds supervision

An SES is a second with at least one of the events:

- N1 CRC-6 errors
- LOF alignment
- LOS
- AIS
- RAI

Two counters for severely errored seconds exist. Both are derived from the downstream PCM port, but one is closely connected to downstream faults while the other one is related to upstream faults.

The downstream counter is increased by 1 for each second with at least one of the events:

- N1 CRC-6 errors or
- 1 LOF or
- 1 LOS or
- 1 AIS

The upstream counter is increased by 1 for each second with at least one RAI.

SES are not counted during unavailable state.

Both SES contours are reported after each BI.

UAS and Unavailable State supervision

UAS is a count of one-second intervals during which service is unavailable. This period of time is referred to as the unavailable state.

The two directions (upstream and downstream) are supervised separately. That is, one of the directions can be in the unavailable state but the other is in the available state.

The counting of ES and SES is stopped for both directions as soon as at least one of the directions is in the unavailable state.

An unavailable state for one direction is declared at the onset of P consecutive SES for the direction of interest. These P seconds are considered to be part of the unavailable time. A new period of available state begins at the onset of Q consecutive seconds with no SES detected. These Q seconds are considered to be part of the available time.

The number of unavailable seconds for each direction is reported after each BI.

50.3.8 Administration

Supervision of transmission faults and transmission quality can be performed in different ways. With the help of parameters, the supervision can be configured to meet a wide range of requirements. The configuration parameters can only be changed when the AO DP is in state "Disable". The parameters of interest are given below.

- The parameters P and Q
 - The parameters P and Q are used for defining unavailable state
 - Value range is 5-15 s
 - Default value is 10 s
- The parameter N1
 - The parameter N1 defines the threshold numbers for SES. Value range is 1-1000
 - Default value is 320
- The configuration parameter T
 - The parameter T defines the time interval for ERATE supervision
 - Value range is 1-5 s
 - Default value is 2 s
- The configuration parameter AFT
 - The configuration parameter AFT defines the Alarm Filtering Time for all the fault supervision functions except RAI supervision
 - Value range is 50-5000 ms
 - Default value is 125 ms
 - The resolution is 1 ms, but the accuracy is ± 25 ms
- The configuration parameter AFT RAI
 - The configuration parameter AFT RAI defines the Alarm Filtering Time for the fault supervision function RAI supervision
 - Value range is 50-5000 ms
 - Default value is 125 ms
 - The resolution is 1 ms, but the accuracy is ± 25 ms
- Base interval for ES, SES, UAS, BFF and SF
 - Valid values: 60 and 126 seconds. The value 126 seconds must be used when BFF supervision is activated in the BSC.

- Base interval for DF and SF
 - Value range: 1-24 h

50.3.9 Multidrop Layer 1

For an RBS configured for multidrop, the function is initiated during restart of CMRU.

For an RBS not configured for multidrop, the function is initiated when the parameter Network Topology is set by the OMT to indicate multidrop (cascade).

AIS Generation

- When entering one of the alarm states LOF, LOS or AIS at PCM-A input, AIS is transmitted on PCM-B output. AIS is transmitted until the alarm state is left
- When entering and leaving alarm states, the alarm filtering time is used (AFT).

50.3.10 CSU ANSI

For an RBS configured for CSU according to ANSI, the function is initiated during restart of the CMRU. The parameter FDL_use in RBS DB is used to control the configuration.

For an RBS not configured for CSU according to ANSI, the function is initiated when the parameter FDL_use in RBS DB is set to indicate CSU ANSI.

The function includes CSU Functionality by use of ANSI bit-patterned messages and loopback commands on the ESF Data Link (DL, message bit m). In this function, DL is referred to as Facility Data Link (FDL).

The commands for Payload Loop Back (PLB), Line Loop Back (LLB), and Universal command deactivate are supported. The commands are used to enable and disable loops within the T1 interface. A received AIS will also disable loops within the T1 interface.

General

- Detection of ANSI bit-patterned messages, received on the FDL, supporting line loopback, payload loopback, and universal loopback deactivate command is supported.

The bit-patterned messages are two-byte words starting with one byte with all ones, followed by a unique byte (command) for each message type. The messages and loops are handled in accordance with ANSI T1.403 section 9.3 (1995).

- Information received on Facility Data Link (FDL) for PCM-A will make an action on PCM-A only. Information received on FDL for PCM-B will make an action on PCM-B only.
- The loop settings will be released at reset of the RBS.
- The code words for universal loopback deactivate, line loopback deactivate, and payload loopback deactivate will be sent on PCM-

A and PCM-B after the function Multidrop Bypass has terminated. First 20 universal loopback deactivate code words are sent, then 20 LLB deactivate code words, and finally 20 PLB deactivate code words are sent.

Sending the loopback deactivation codes above minimizes the risk for faulty loops to be left in the network (in the RBS neighbor nodes) as result of loop activation codes sent when the Multidrop Bypass function is enabled.

- The LLB and PLB may co-exist in the RBS, but the LLB will be used. The PLB will be in use after release of the LLB. A PLB can be set as a "background" loop to an LLB. The universal loopback deactivate code releases both loops. A received AIS releases also both loops.
- Both CSU line loopback and CSU payload loopback have higher priority than the DXX line loopback. This means that the DXX line loopback will be suspended when CSU loopbacks (PLB and LLB) are activated. When the CSU loopback is deactivated, the DXX loopback is resumed.

Line Loop Back (LLB)

The Line Loop Back is a loopback in which the signal returned towards the source of the loopback command consists of the full 1.544 Mbit/s signal. The loop includes no jitter attenuation. The bit sequence integrity will be maintained for the signal and no change in the framing, and no removal of bipolar violations.

The LLB is supported by two specific commands:

1. The command "Line Loopback Activate" sets the line loop.
The code word "00001110 11111111" received five times in a sequence will make an action to connect a line loopback. The rightmost bit is received first.
2. The command "Line Loopback Deactivate" releases the line loop.
The code word "00111000 11111111" received four times in a sequence will make an action to disconnect a line loopback.

Payload Loop Back (PLB)

The Payload Loop Back is a loopback in which the signal returned towards the source of the loopback command consists of the payload of the received signal. The signal has the bit sequence integrity retained and newly generated ESF framing, but not necessarily maintaining the integrity of the channel time-slots of the received signal.

The PLB is supported by two specific commands:

1. The command "Payload Loopback Activate" sets the payload loop.
The code word "00010100 11111111" received five times in a sequence will make an action to connect a payload loopback.
2. The command "Payload Loopback Deactivate" releases the payload loop.

The code word "00110010 11111111" received four times in a sequence will make an action to disconnect a payload loopback.

Universal Loopback Deactivation Signals

1. The command "Universal Loopback Deactivate" releases all loops whether they are of type LLB or PLB (or both).

The code word "00100100 11111111" received four times in a sequence will make an action to disconnect a loop of type LLB or PLB, or both loops.

2. A received AIS makes the same action as the universal loopback deactivate command, releasing both payload and line loopbacks. The loop release is made after the Alarm Filtering Time (AFT) has expired. The AFT is described in section Supervision of Transmission Faults under paragraph Description, and in section Administration.

The default setting of FDL_use is:

Used only for RAI

The parameters can be modified from OMT. The new setting is activated immediately. Thus, the updated parameters are used when the selection of FDL use is performed.

Two PCM paths are supported: PCM-A and PCM-B.

This page is intentionally left blank

51 Terrestrial Link Handling

This function specification covers RBS functions for layer 2 communication on A-bis.

The function Layer 2 Link Handling is used for layer 2 signalling to/from RBS.

51.1 References

Whenever a reference is made to a function described in another chapter, please refer to the table of contents to find the appropriate chapter.

51.2 Concepts

Operation and Maintenance Link

Layer 2 communication link for operation and maintenance services on A-bis.

Radio Signalling Link

Layer 2 communication link for traffic services on A-bis.

51.3 Function

51.3.1 Layer 2 Link Handling of OML and RSL

The link layer used for signalling on the A-bis interface between BSC and BTS is established and maintained according to Technical Specification /GSM 08.56/.

LAPD (Link Access Protocol on the D-channel) is used for layer 2 signalling. Signalling conforms to /GSM 08.56/.

51.4 Operational Conditions

51.4.1 Operation and Maintenance

Maintenance functions relating to definition of layer 2 address (TEI) are described within the context of Operation and Maintenance Terminal.

51.4.2 Capabilities

Not applicable.

This page is intentionally left blank

52 Channel Distribution Function

This chapter covers RBS functions for Layer 2 communication on A-bis.

The function Channel Distribution switches channels in the transport network interface to different RBS entities.

The function Scanning of Terrestrial Channels makes it possible to communicate with RBS on a non-predefined terrestrial channel.

The function Sharing Terrestrial Channel makes it possible to communicate with both CMRU and a TRX on a common terrestrial signalling channel.

The function Concentration of LAPD Signals makes it possible to reduce the number of required physical links between the BSC and the BTS.

The functions Multidrop and Multidrop Bypass makes it possible for several RBSs to share one PCM line.

52.1 References

Whenever a reference is made to a function described in another chapter, please refer to the table of contents to find the appropriate chapter.

52.2 Concepts

| | |
|-------------|---|
| Channel | A channel is a 16, 32 or 64 kbit/s connection between two entities connected to the switch (see Figure 101 on page 430). A 64 kbit/s connection between a time slot in the transport network interface and a signalling port in a TRX is an example of a channel. |
| CF | Central Functions. Functional entity for handling of RBS common functions. |
| CMRU | Central Main Replaceable Unit. An RBS has exactly one Central Main RU. In the RBS 2000 hardware architecture, the Distribution Switch is the Central Main RU. |
| Local Mode | A unit in Local mode has no communication with the BSC over the A-bis interface and is therefore not in operation. |
| OML | Operation and Maintenance Link. Layer 2 communication link for operation and maintenance services on A-bis. |
| Remote Mode | A unit enters Remote mode when accepting a layer 2 link establishment on A-bis. It remains in Remote mode until it is manually switched to Local mode. |

| | |
|--------------------------------|---|
| RSL | Radio Signalling Link. Layer 2 communication link for traffic services on A-bis. |
| Terrestrial Channel | <p>Terrestrial channels are physical channels for communication with, for example, the BSC over the Transport Network. There are different types of terrestrial channels, dependent on their use:</p> <ul style="list-style-type: none"> – Terrestrial Signalling channels – Terrestrial Traffic channels <p>Terrestrial signalling channels are used for LAPD signalling only.</p> |
| Unoccupied Terrestrial Channel | An unoccupied terrestrial channel is a physical channel which can be used as, but is currently not used as, a terrestrial signalling channel or as a terrestrial traffic channel. |

52.3 Functions

The CDF (Channel Distribution Function) switches channels between the entities connected to the switch. See figure below:

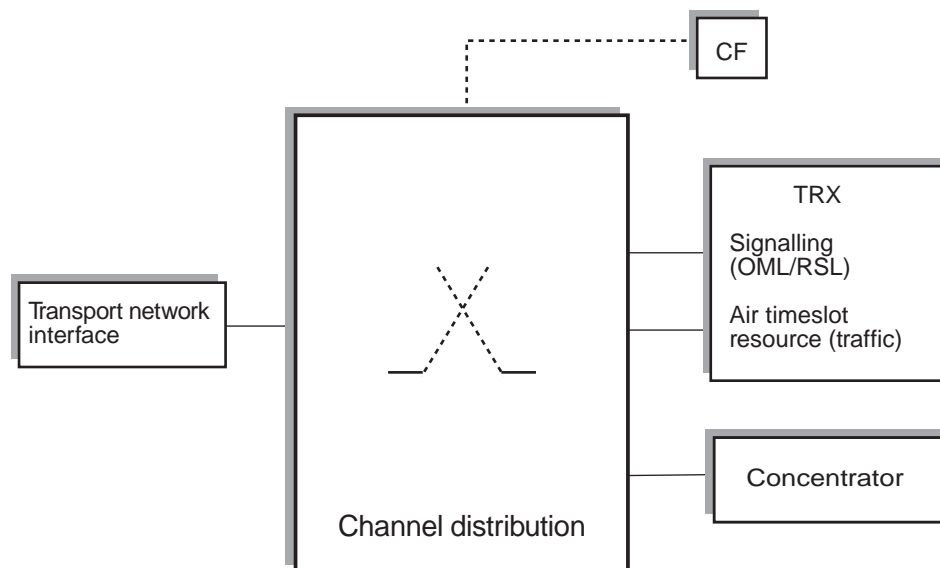

01_0297B

Figure 101 Channel distribution function (CDF)

- All connections through the switch are configured by A-bis commands as described within the context of Functionality Administration. The configuration commands consist of a number of connections between time slots in the Transport network, the Concentrator and the TRXs.

- Configuration includes setup of new connections and release of connections no longer required. Connections which are the same in the old and the new configuration are left undisturbed.
- Idle pattern is transmitted on unoccupied time slots in the transport network interface. An unoccupied time slot is a time slot which has no channel assigned to it. The idle pattern is 01010100 for a 2 Mbit/s system and 01111111 for a 1.5 Mbit/s system.
- If the time slot is partly used, an idle pattern will be used for all unoccupied 16 kbit/s sub-time slots within that time slot. The subslot idle pattern is 01 for 2 Mbit/s systems and 11 for 1.5 Mbit/s systems.
- If the time slot is partly used, an idle pattern will be used for all unoccupied 16 kbit/s sub-time slots within that time slot. The subslot idle pattern is 01 for 2 Mbit/s systems and 11 for 1.5 Mbit/s systems.
- Maximum capacity (Transport Network Interface) is 31 time slots between the BSC and BTS for a 2 Mbit/s system and 24 time slots for a 1.5 Mbit/s system. This corresponds to one PCM line towards the BSC.
- One signalling channel can be switched to each TRX, the capacity of this channel is 16, 32 or 64 kbit/s.
- Eight 16 kbit/s traffic channels can be switched to each TRX, that is, one for each available ATSR.
- 24 signalling channels can be switched to the concentrator, the capacity of each channel is 64 kbit/s.
- The physical mapping, which is needed to configure the switch, is based on ICPs. Each ICP represent a 16 kbit/s substrate connection point.
- The ICPs in the range 4 – 255 defines the incoming PCM time slots according to Table 122 on page 431. The ICPs for time slots 25 – 31 are only valid for 2 Mbit/s systems.

The range 256 – 351 defines the concentrator.

The ranges 512 – 575 and 640 – 711 define the TRXs, see Table 123 on page 432.

Table 122 ICPs range 4 – 255

| ICP | Usage | |
|---------|-------|-------|
| 4-7 | PCM-A | TS1 |
| 8-11 | PCM-A | TS2 |
| ... | ... | |
| 122-127 | PCM-A | TS 31 |
| 132-135 | PCM-B | TS 1 |
| 136-139 | PCM-B | TS 2 |
| ... | ... | ... |
| 250-255 | PCM-B | TS 31 |

Table 123 ICPs ranges 512 – 575 and 640 – 711

| TRX | Signalling | Traffic |
|-----|------------|---------|
| 0 | 512-515 | 516-523 |
| 1 | 524-527 | 528-535 |
| 2 | 536-539 | 540-547 |
| 3 | 548-551 | 552-559 |
| 4 | 560-563 | 564-571 |
| 5 | 572-575 | 576-583 |
| 6 | 640-643 | 644-651 |
| 7 | 652-655 | 656-663 |
| 8 | 664-667 | 668-675 |
| 9 | 676-679 | 680-687 |
| 10 | 688-691 | 692-699 |
| 11 | 700-703 | 704-711 |

52.3.1 Concentration of LAPD Signals

The purpose of LAPD concentration is to reduce the number of required physical links between the BSC and the BTS. This is done by allowing a number of TRXs to use the same physical transmission link for LAPD signalling between the BSC and the BTS.

The function concentrates LAPD messages from a number of TRXs onto one physical link to the BSC (uplink). It also deconcentrates LAPD messages received on one physical link from the BSC (downlink), sending them forward to their destinations.

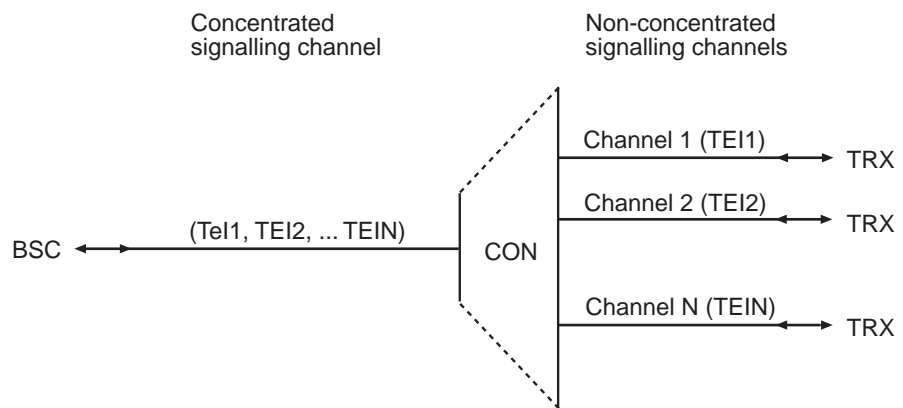

01_0301A

Figure 102 One N:1 concentrator Connection Group (CG)

Messages are sent forward to their destinations without adding, deleting or changing information.

The concentrator is configured by A-bis commands as described in chapter "Functionality Administration".

For each concentrated signalling channel there is a transmit queue for uplink messages to the BSC. The queue length is supervised as described in "Self Test and Supervision". If a new message is received

when the queue is full, all unnumbered information (UI) frames are discarded from the queue. If the queue still is full, the new message is discarded.

The bit rate for the concentrated channels is limited to 64 kbit/s, that is, LAPD concentration and LAPD multiplexing can not be combined.

52.3.2 Scanning of Terrestrial Channels

The function is initiated:

- When the CMRU is in Local mode and the Remote button is pressed
- When the CMRU is in Remote mode and (re-)started
- When CF has lost its layer 2 connection to BSC
- When the CF link is disconnected (reception of DISC command frame)

RBS searches all terrestrial signalling channels, plus a number of unoccupied terrestrial channels, for data link establishment attempts directed towards CF.

Searching for the establishment attempt is performed by the CF in intervals of one second. The searching can be performed in two ways.

Initially, when no valid CDF configuration exists, one set of unoccupied terrestrial channels is searched in each interval. If no establishment attempt is found during an interval, the search is continued on the next set of unoccupied terrestrial channels. The search is repeated until an establishment attempt is found.

If the scanning function is initiated when a valid CDF configuration exists, the search in each interval is performed on all the configured terrestrial signalling channels plus one set of unoccupied terrestrial channels. Thus all unoccupied terrestrial channels are searched in a cyclic way and all configured terrestrial signalling channels are searched continuously.

After a search-time of 5 minutes, the entire configuration of the channel distribution function except TN O&M channel is erased (all set up connections are lost and have to be reconfigured). The search continues but now all terrestrial channels are defined as unoccupied.

time slot for TN O&M is considered as occupied and is not scanned in CF scanning procedure.

The function is terminated when the layer 2 link to CF is established or when CMRU enters Local mode.

52.3.3 Sharing Terrestrial Signalling Channel

The function is initiated when the channel distribution function becomes configured in such a way that the same terrestrial signalling channel is used for signalling to both MO CF and to one or more TRXs. This is the normal condition that occurs at configuration of the first TRX.

It is also initiated when RBS has, during scanning of terrestrial channels, found a link establishment to CF on a terrestrial signalling channel already used for signalling to one or more TRXs.

The function shares signalling to/from MO CF and signalling to/from one or more TRXs on a shared terrestrial signalling channel.

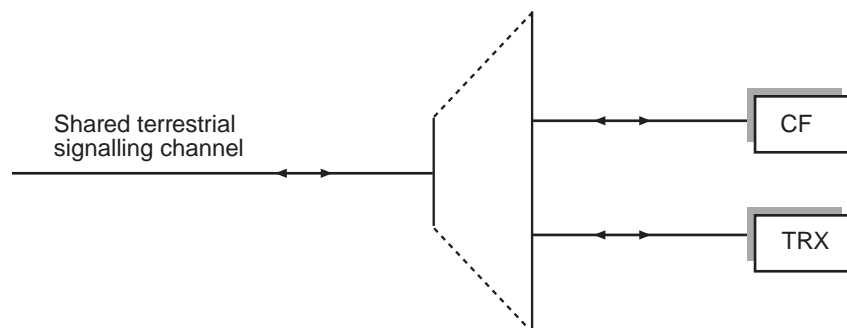

01_0299B

Figure 103 Sharing terrestrial signalling channel

Messages are sent forward to their destinations without adding, deleting or changing information.

Messages addressed to MO CF are sent to MO CF. All other messages are sent to the TRXs.

The function terminates when MO CF has lost its data link connection. At termination, MO CF is disconnected from the shared terrestrial signalling channel. The signalling link to/from the TRXs is undisturbed at the disconnection.

It also terminates when the channel distribution function becomes re-configured in such a way that signalling to any TRX is no longer performed on a shared terrestrial signalling channel. This is the normal way to terminate this function.

52.3.4 Multidrop

For an RBS configured for multidrop, the function is initiated during restart of the CMRU.

For an RBS not configured for multidrop, the function is initiated when the parameter Network Topology is set by the OMT to indicate multidrop (cascade).

The multidrop connected RBSs are connected so that each RBS uses its port A towards the BSC and port B towards the next RBS. The latter RBS is connected in the same way with port A towards the previous RBS (and indirectly the BSC), port B towards the next RBS, and so on.

Only RBSs supporting multidrop can be included in the multidrop connection chain. Figure 104 on page 435 illustrates the case with three RBSs.

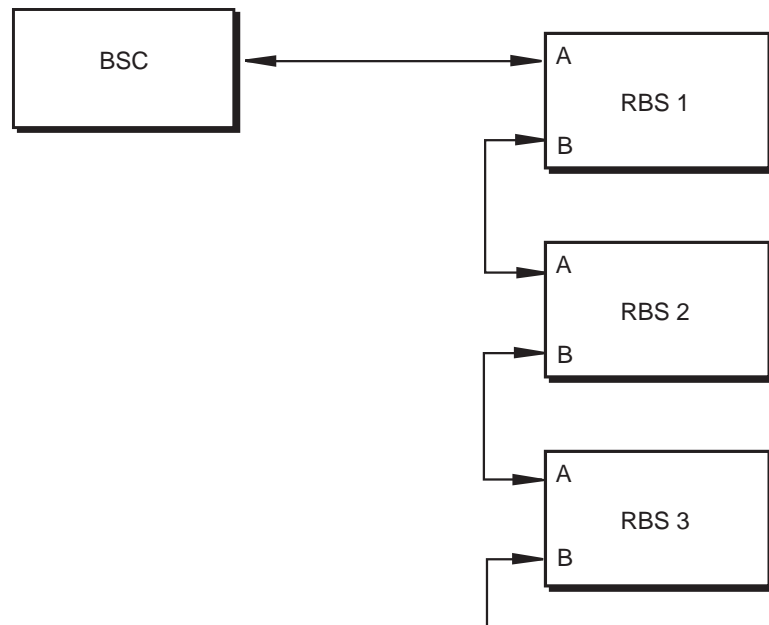

02_0301A

Figure 104 Linear Cascade Connection

The multidrop function only handles 64 kbit/s time slots.

A 64 kbit/s time slot is considered to be used by the RBS if any of its sub-time slots are configured in the IS or used for the CF link or remote OMT link or used for DXX communication.

If, for example, ICP 7 is used in the IS configuration, the whole time slot 2 is considered to be used by the current RBS.

Figure 105 on page 436 shows a schematic example with two RBSs and seven time slots. The first RBS uses time slots 2, 5 and 6 and the second uses 1, 3 and 4.

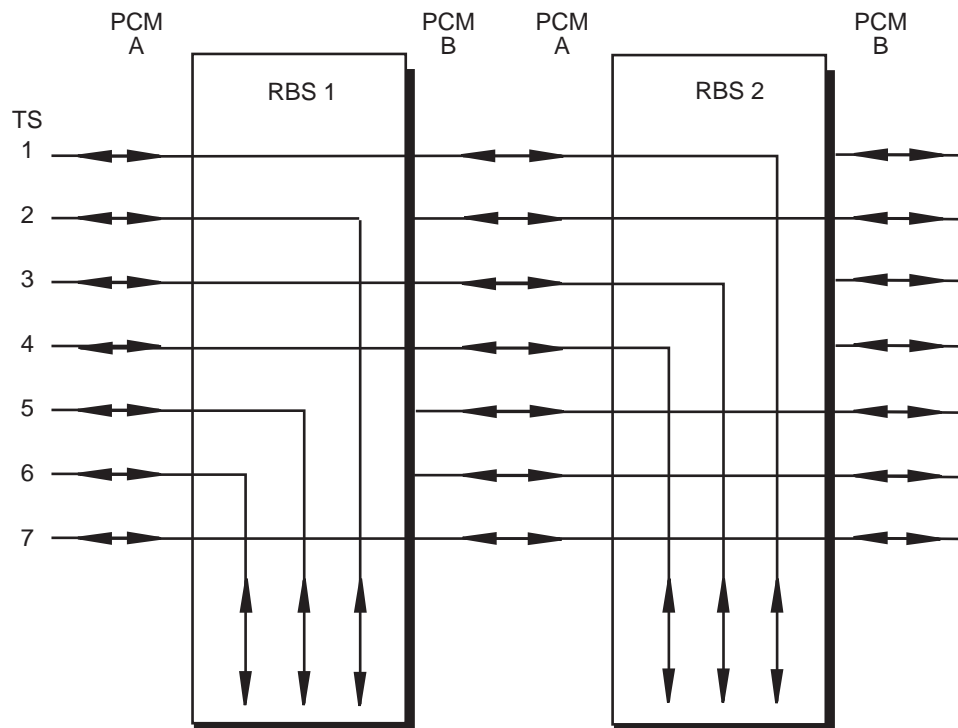

03_0301A

Figure 105 Multidrop example

All time slots, not used by the own RBS, are transparently connected between PCM-A and PCM-B.

The time slots used by the RBS will be connected from PCM A to the respective destination in the RBS. These time slots will have valid idle pattern transmitted on PCM B and incoming data on PCM-B is ignored.

As long as there are time slots available, up to five RBSs can be connected in a Multidrop chain. The number of time slots available depends on the number of TRXs, and if the functions Sharing Terrestrial Signalling Channel and Concentration of LAPD signals are used. See sections "Sharing Terrestrial Signalling Channel" and "Concentration of LAPD Signals".

For a description of Multidrop with Line Build Out (LBO) for DS1 transmission, see section "Line Build Out (LBO)".

The RBS located at the end of the linear cascade chain transmits idle pattern on all time slots not dedicated for the RBS itself on PCM-A output.

- When entering at least one of the alarm states LOF, LOS or AIS at PCM-B input, the RBS is considered to be the RBS located at the end of the linear cascade chain, presuming that PCM-A is not in loop mode. It is considered to be so until the alarm state is left.
- When entering loop mode (CSU loops or DXX line loop back) at PCM-B, the RBS transmits idle pattern on all time slots not dedicated for the RBS itself on PCM-A output presuming that PCM-A is not in loop mode. Idle pattern is transmitted until the loop mode on PCM-B is left.

- When entering loop mode (CSU loops or DXX line loop back) at PCM-A, idle pattern is transmitted on PCM-B output presuming that PCM-A is not in loop mode. Idle pattern is transmitted until the loop mode on PCM-A is left.

Idle pattern is not transmitted on time slot for the TN O&M channel.

- When entering and leaving alarm states, the Alarm Filtering Time (AFT) is used.
- When entering and leaving loop modes AFT is not used.

The multidrop function is terminated when the parameter Network Topology is set not to indicate multidrop.

52.3.5 Multidrop Bypass

This function is only valid if it is supported by the hardware.

The function handles transparent connection from PCM-A to PCM-B during such times that normal multidrop function is unavailable. This can be due to:

- Power off
- Fatal software fault
- Fatal hardware fault
- Reset button on CMRU is pushed
- BSC ordered reset
- Replacement of RBS

The multidrop connected RBSs are connected so that each RBS uses its port A towards the BSC and port B towards the next RBS. The latter RBS is connected in the same way with port A towards the previous RBS, port B towards the next RBS, and so on. Figure 106 on page 438 illustrates the case with two RBSs and with the first RBS in bypass mode.

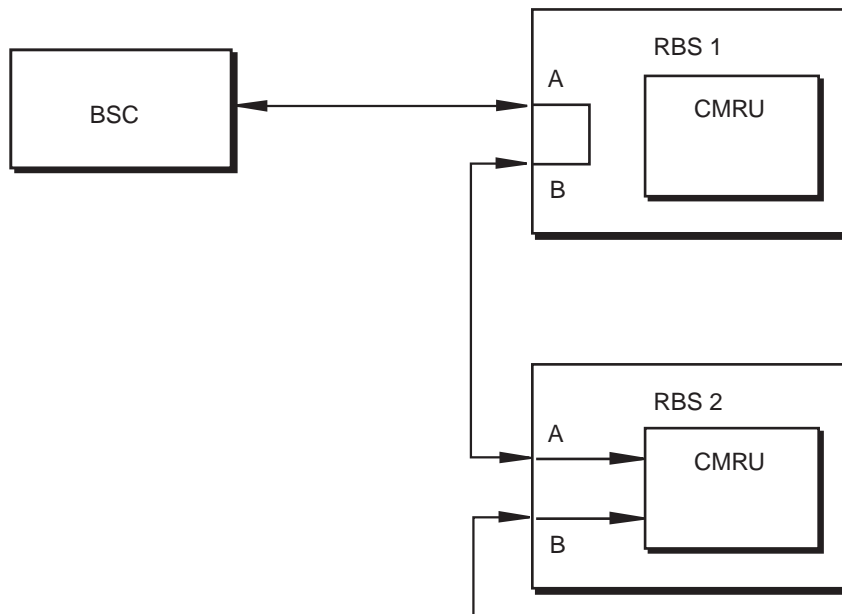

04_0301A

Figure 106 Linear Cascade connection with bypass

When switching to and from bypass mode, a disturbance will occur on the PCM line.

52.3.6 Remote OMT Link

The function is initiated during restart of CMRU.

The RBS searches for Remote OMT establishment on PCM A time slot 23 whenever this time slot is not used by other functions. The time slot is in use when it:

- is configured in the IS (subchannels with bitrate other than 64 kbit/s, TN O&M time slots, traffic functions)
- carries the CF link
- is scanned for the CF link

The remote OMT link will be disconnected if a new IS configuration configures PCM A time slot 23 for either:

- traffic functions
- subchannels with bitrate other than 64 kbit/s

The remote OMT link uses a protocol based on LAPD. The TEI value used is 0 and the SAPI value used is in the range 20 - 30.

52.4 Operational Conditions

52.4.1 Operation and Maintenance

Not applicable.

52.4.2 Capabilities

The maximum number of concentration groups is 12 and the concentration ratios 1:1 to 12:1 (this is only valid for RBS).

The maximum scanning capacity is 24 channels per 1-second interval.

Each TRX handles two links, one OML- and one RSL-link on a common terrestrial signalling channel.

The CMRU handles one OML link, normally on a signalling channel shared with a TRX.

When multidrop is used only one PCM (PCM-A) path can be used for communication towards the BSC.

A maximum of five RBSs can be connected in a linear cascade chain.

This page is intentionally left blank

53 Transport Network O&M Functions - DXX Support

53.1 Introduction

This Function Specification covers RBS functions for Transport Network Operation and Maintenance.

The functions are divided into two groups with Transport Network Operation and Maintenance generic functions including:

- Enabling and detection of TNOM protocol
- Allocation of TNOM time slot

and DXX specific functions including:

- Node identity
- Node access control
- Node real time control
- Current alarm report
- Alarm history report
- G.821 Performance reports
- Fault masks
- Loop-back
- Node inventory
- DXX protocol handling

With Transport Network O&M and "DXX support" in RBS 2000, it is possible to connect an RBS to DXX without using a DXX transport module.

In Figure 107 on page 442, an example of how the functionality "DXX support" can be used in a network is shown.

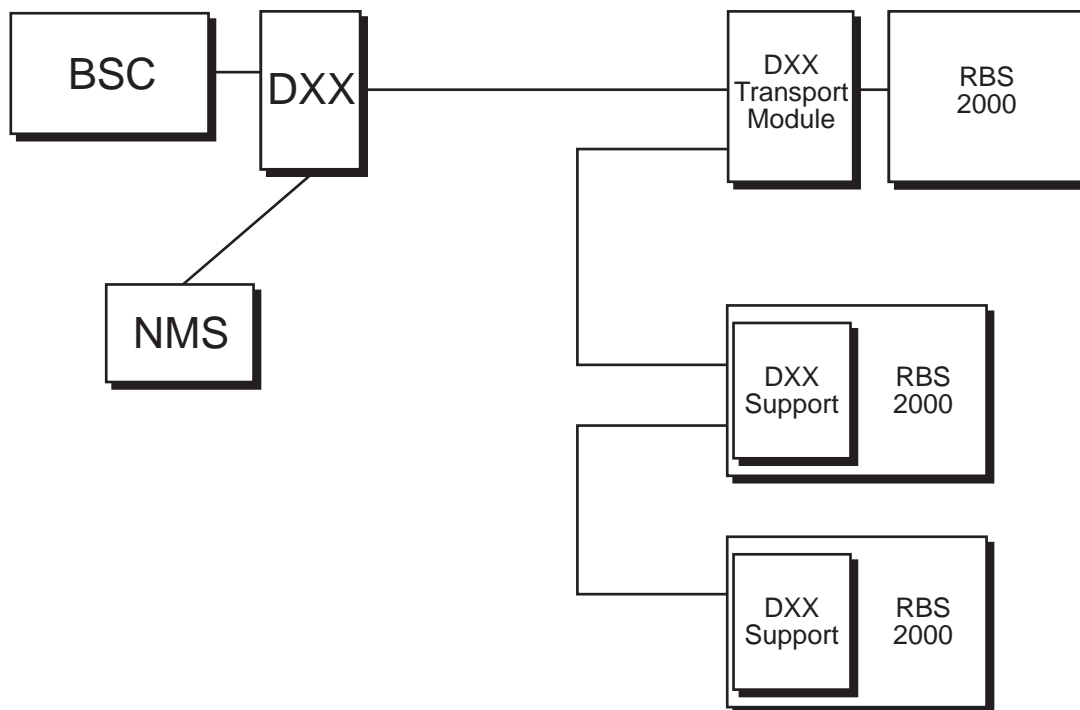

P002615B

Figure 107 Example of DXX support in an RBS 2000 network

The RBS 2000 nodes including the DXX support functions will be visible as nodes in DXX/NMS, and the layer 1 transmission in the RBS nodes will be supervised from NMS. The DXX support provides early warnings in case of faults and degradation of the trunks, enabling the operator to take actions at an early stage. The functions are described in Section 53.4 on page 444.

DXX uses specified layer 3, and layer 7 protocols for the transport network O&M. The layer 2 protocol used is LAPB. The protocols used are described in Section 53.4 on page 444.

53.2 References

Whenever a reference is made to a function described in another chapter, please refer to the table of contents to find the appropriate chapter.

All ITU-T references refer to the White Book (ITU = International telecommunications Union).

| | |
|----------|--|
| [TIH_E1] | Function group Transmission Interface Handling G.703 2048 kbit/s (chapter 42). |
| [TIH_T1] | Function group Transmission Interface Handling DS1 1544 kbit/s (chapter 41). |
| [X.25] | ITU-T Recommendation X.25, interface between DTE and DCE. |

53.3 Concepts

In Figure 108 on page 443 , the nomenclature for DXX is stated.

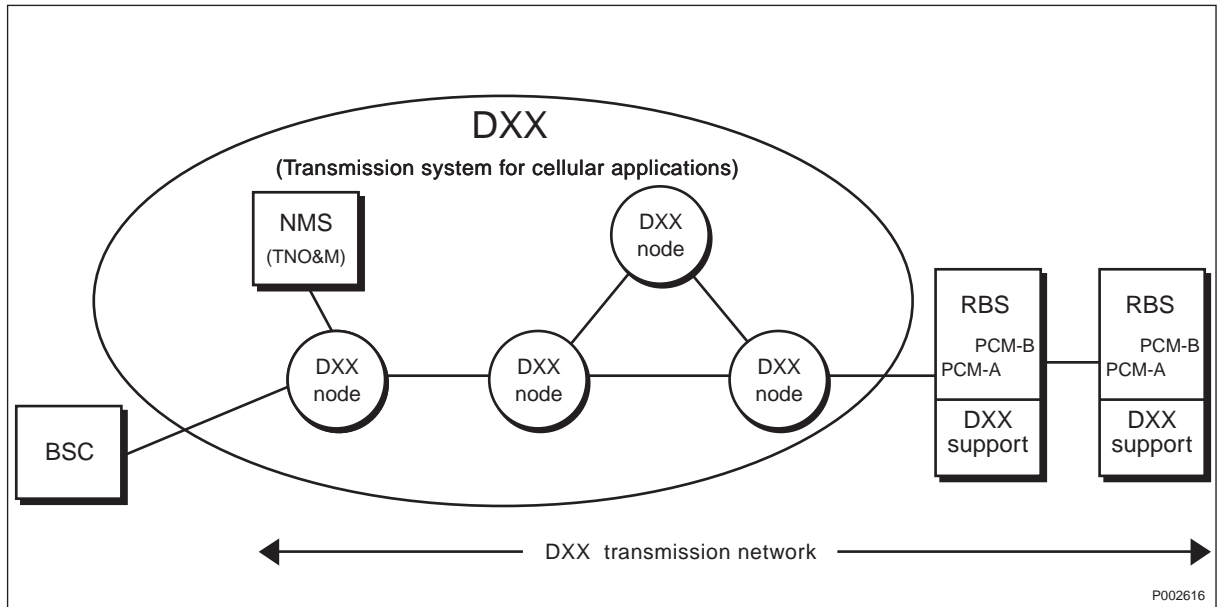

Figure 108 DXX terminology

| | |
|----------------------|--|
| DXX | DXX is a transmission system for cellular applications. It includes O&M and switching functionality (among others). The O&M centre is named NMS. |
| DXX node | A node in the DXX system. |
| DXX support | DXX support is O&M functions in RBS 2000 intended for DXX. DXX support is a portion of the functionality in a DXX transport module. |
| DXX transport module | A DXX node suitable to fit in the RBS 2000 cabinet. |
| NMS | The Network management system in DXX. Hence, NMS is TN O&M for DXX. |
| TN O&M | Centrally located management system for transport networks and transmission equipments in general, such as digital cross connectors, line terminals, multiplexors and microwave links. |
| RBS2000–DXX O&M | The protocols used between an RBS with DXX support and a DXX node with RBS support. |

53.4 Functions

53.4.1 Enabling and Detection of TNOM Protocol

This function is initiated when the parameter `TNOM_use` in the RBS database is set to on.

This function is used to control the enabling and disabling of the Transport Network O&M functions in RBS 2000. The parameter `TNOM_use` stored in RBS DB is used for this.

When the function is disabled no management timeslot is dedicated for the Transport Network O&M functions. Instead the timeslot will be used by BSS for internal use i.e. for traffic and signalling.

When is enabled the Transport Network O&M functionality is active, and will work as described in this function specification. The first received message after the function has been enabled is detected and enables the protocol stack for the received protocol if recognized.

If the protocol is not recognized no protocol stack is enabled. This functionality can be regarded as an auto detection of TNOM protocol type.

53.4.2 Allocation of TNOM Timeslot

This function is initiated during restart of the DXB if the parameter `TNOM_use` in RBS DB is already set to ON, otherwise the function is initiated when the parameter is set to ON.

The communication between RBSes or RBS and DXX is performed on a 64 kbit/s timeslot in the PCM link. The PCM link is either 2048 or 1544 kbit/s.

This function allocates a 64 kbit/s timeslot for the TN O&M management channel. When RBS is configured as stand alone, one timeslot with the same timeslot number is allocated for both PCM-A and PCM-B. When RBS is configured in cascaded chain, the same timeslot number is used for PCM-A and PCM-B. A full 64 kbit/s timeslot is used, thus not supporting FDL or spare bits in TS 0 to be used.

The TNOM timeslot number is stored in RBS DB.

The TNOM timeslot has priority to the access of timeslots within RBS. Timeslot used for TNOM will be removed from available timeslots shown in capabilities.

53.4.3 DXX Node Identity

This function is initiated during restart of the DXB if the parameter `TNOM_use` in RBS DB is already set to ON, otherwise the function is initiated when the parameter is set to ON.

This function sets and changes the Node id for the RBS. The RBS node has a unique node identity (a node number) for communication with the DXX network and for appearance in the NMS. The node identity is stored in RBS DB and does not have to be the same as the RBS TEI value.

The node identity can be set and changed from the OMT, as well as from the DXX. No one has priority on the parameter, i.e. the last value set is the valid node id.

53.4.4 DXX Node Access Control

This function is initiated during restart of the DXB if the parameter TNOM_use in RBS DB is already set to ON, otherwise the function is initiated when the parameter is set to ON.

The RBS support a node access control that is used to limit access rights to the node from DXX. This function maintains the node access registers.

The value for node access possible to set from DXX are 1 to 65535 for limited access rights. If the node access list is empty (that is, it does not contain any non-zero access control id) then all management operations are allowed. If the node access control list contains one or more non-zero access id:s then only the Invokes (requests) having the access id which can be found in the node access list are processed.

The RBS node will always respond on an invoke containing the node access id equal to zero.

53.4.5 DXX Real Time Control

This function is initiated during restart of the DXB if the parameter TNOM_use in RBS DB is already set to ON, otherwise the function is initiated when the parameter is set to ON.

This function controls the administration of "Real time of node" and "Relative time of unit" clocks.

It is possible from DXX to set a real time clock (Real time of node). This clock is used for time stamps in alarm and performance reports. The real time clock is used with a relative clock counter (Relative time of unit), that is used to make time-stamps on individual fault events.

The real time of node counter has the possible values between 0 and 4 294 967 295. The relative time of unit counter has the same value range. Both counters are incremented by one every 10 ms, where the real time counter can be reset by NMS command while the relative counter is free running.

53.4.6 DXX Current Alarm Report

This function is initiated during restart of the DXB if the parameter TNOM_use in RBS DB is already set to ON, otherwise the function is initiated when the parameter is set to ON.

This function sends Alarm reports from RBS to DXX upon requests. The DXX polls the RBS asking for changes in fault events, and request reports if the fault event condition has changed since the last poll.

Alarm reports can be sent for monitored faults such as Loss Of Signal (LOS), Loss Of Frame (LOF), Alarm Indication Signal (AIS), Remote Alarm Indication (RAI) etc. the fault conditions supervised are related to PCM-A, PCM-B and common parts respectively.

The reports uses the Real time of node for time stamps and the individual faults uses the Relative time of unit for their time stamps. See Section 53.4.6 on page 445.

The fault conditions monitored within the common parts of the RBS are:

- Flash check sum error
A problem has been found when saving parameters to the non-volatile memory.
- Reset
There has been a unit reset (detected always after the power-up of the unit), and the TN O&M functions has restarted. The reset is reported as a delta alarm event. With delta alarm event means an event has occurred but is still not active.

The fault conditions monitored within the interfaces PCM-A and PCM-B of the RBS are:

- Rx signal missing (LOS)
According to [TIH_E1] and [TIF_T1].
- Frame alignment lost (LOF)
According to [TIH_E1] and [TIF_T1].
- Rx signal AIS
According to [TIH_E1] and [TIF_T1].
- BER 10^{-3} (ERATE)
According to [TIH_E1] and [TIF_T1]. When CRC-4 is enabled the CSES is used in accordance with [TIH_E1].
- Remote Alarm Indication (RAI)
According to [TIH_E1] and [TIF_T1]
- Loop - Mux/Demux back to line
This status is activated when the DXX loop is activated. Rx data is looped back to the interface transmitter.
- G.821 limit event
This fault will be activated as a delta event when at least one G.821 performance limit has been exceeded in a 15-minute period. See also Section 53.4.8 on page 447. With delta alarm event means an event has occurred but is still not active.
- G.821 Unavailable state (UAST)
This signal will be activated when the state of the signal becomes unavailable. The fault will be deactivated when the state becomes available again. Unavailable state is declared at the onset of 10 consecutive SES. These 10 seconds are considered to be part of the unavailable time.

- Fault masked/test
This fault will be activated when the interface fault mask setting is ON (all interface faults will be cleared).
- Rx Buffer slip/BUFIN (Slip)
This fault is only used for E1. The fault is activated if one or more buffer slips have been detected during the last hour. A slip is defined as where one frame (0.125 ms) is either lost or duplicated.
- Status for CSU line loop back, LLB (T1)
This message is only used for T1. It indicates that the CSU line loop back is activated.
- Status for CSU payload loop back, PLB (T1)
This message is only used for T1. It indicates that the CSU payload loop back is activated.

53.4.7 DXX Alarm History Report

This function is initiated during restart of the DXB if the parameter TNOM_use in RBS DB is already set to ON, otherwise the function is initiated when the parameter is set to ON.

This function sends Alarm history reports to DXX. The reports are sent from RBS to DXX upon request. The fault conditions are described in Section 53.4.6 on page 445.

The RBS maintains an alarm history in its alarm event log which is a ring buffer for 100 latest alarm events. The alarm events are:

alarm on, alarm off and delta (combined alarm on and off).

The delta alarm event type is used when an alarm is turned on and off within a short period, that is, an alarm has occurred but is not still active.

53.4.8 DXX G.821 Performance Reports

The following statistics are provided in G.821 performance reports:

- Total Time (TT)
- Available Time (AT)
- Severely Errored Seconds (SES)
- Errored Seconds (ES)
- Degraded Minutes (DM)
- Number of CRC errors from far end (CRCE)
- Number of seconds when RAI has been received (RAI)
- Number of Code Violation (CV)
- Number of CRC block errors (CRC)
- Number of faulty Frame Synchronization Word (FSW)
- Number of lost Frame Synchronization (FS)

- Number of Rx Buffer slip (BUFIN)

Each of the statistics are supported by two groups of registers and two groups of counters providing the performance data. The registers and counters can be read and reset.

They are:

- Counters for current 15 minutes report
- Registers for previous 15 minutes report
- Counters for current 24 hours report
- Registers for previous 24 hours report

The information of the 15 minutes counters and registers are sent together in one report. The information of the 24 hours counters and registers are sent together in another report.

G.821 limits alarm

An alarm is activated when at least one G.821 performance limit has been executed in a 15-minute period. The performance limits can be changed from DXX.

The G.821 Performance limits supervised are:

- Limit for Severely Errored Seconds (SES), with the values between 0 and 900.
- Limit for Errored Seconds (ES), with the values between 0 and 900.
- Limit for CRC-E, with the values between 0 and 65000.
- Limit for Remote Alarm Indication (RAI), with the value between 0 and 900.

G.821 Performance basic statistics counters

For limited statistics a number of counters are reported with a performance counter value. The counters can be read and reset on request.

The following counters are supported:

- Total Time (TT)
- Available Time (AT)
- Severely Errored Seconds (SES)
- Errored Seconds (ES)
- Degraded Minutes (DM)

Description of performance data

AT Available time is the total time (TT) minus unavailable time (UAT).
A period of unavailable time (UAT) begins at the onset of 10 consecutive SES.

These 10 seconds are considered to be part of the unavailable time. A new period of available time begins at the onset of 10 consecutive seconds with no SES detected. These 10 seconds are considered to be part of the available time.

SES

A severely errored second (SES) is a second with at least one of the following events.

For E1 system:

- At least N1 CRC errors (when CRC is used)
- At least N4 Faulty FSW (when CRC is not used)
- Loss of frame alignment (LOF)
- Loss of signal (LOS)
- Alarm indication signal (AIS)

and for T1 system:

- At least N1 CRC errors
- Loss of frame alignment (LOF)
- Loss of signal (LOS)
- Alarm indication signal (AIS)

The default values N1 and N4 are stated in, and the SES is performed in accordance with [TIH_E1] and [TIH_T1].

ES

An error second (ES) is a second with at least one of the following events:

For E1 system:

- At least 1 CRC errors (when CRC is used)
- At least 1 Faulty FSW (when CRC is not used)
- Loss of frame alignment (LOF)
- Loss of signal (LOS)
- At least one slip
- Alarm indication signal (AIS)
- At least N1 CRC errors
- Loss of frame alignment (LOF)
- Loss of signal (LOS)

| | |
|-------|--|
| | - At least one slip |
| | - Alarm indication signal (AIS) |
| | The SES is performed in accordance with [TIH_E1] and [TIH_T1]. |
| DM | One minute interval with one of the following but not SES or UAT: For E1 system: - 123 CRC errors (when CRC is used) - 2 faulty FSW (when CRC is not used) and for T1 system: - 52 CRC errors |
| CRCE | Numbers of CRC errors from far end is indicated by the E-bit in time slot 0. Only used when the node is configured for CRC-4. |
| RAI | Number of seconds when Remote Alarm Indication (RAI) has been received. |
| CV | Number of line code errors (when the line code has been violated). This is not reported when the CRC-4 is used (enabled). |
| CRC | Number of Cyclic Redundancy Check (CRC) block errors detected. |
| FSW | Numbers of faulty frame synchronization words. One count every time one or more faulty bits in frame alignment word has been detected. |
| FS | Numbers of lost frame alignment. One count every time the frame synchronization is lost. |
| BUFIN | Number of detected buffer slips on the receiver interface (Rx). |

53.4.9 DXX Fault Masks

This function is initiated during restart of the DXB if the parameter TNOM_use in RBS DB is already set to ON, otherwise the function is initiated when the parameter is set to ON.

This function maintains fault mask filters, making it possible to inhibit fault reporting. Two type of fault masks do exist:

- Fault freezing, and
- Fault masks

Fault freezing

It is in RBS possible to set a fault mask to freeze fault monitoring of a specified block at a specified period of time. The blocks are PCM-A, PCM-B and Common parts (SW faults). The time out value is 0 to 10 000 000 seconds.

With the fault freezing activated the fault status of the RBS is frozen, i.e. the faults are neither updated nor reset. Fault monitoring is enabled automatically after the time-out time has expired or immediately by the management operation where the time-out time is set to zero.

Fault masks

It is possible from DXX to mask all faults from an RBS or from a specific interface (i.e. prevent the interface from generating alarms). It is also possible from DXX to specify certain individual fault masks.

When the fault mask is active the potential faults are neither supervised, nor reported, except for an alarm indicating that the fault mask is enabled.

The following attribute (status) have individual fault masks possible to enable/disable on interface basis (PCM-A and PCM-B).

- AIS inhibit (also called AIS Failure fault mask):
When ON, a received AIS failure does not generate an alarm. This parameter is OFF as a default.
- RAI inhibit (also called RAI fault mask):
When ON a received RAI does not generate an alarm. This parameter is OFF as default.

The AIS inhibit or RAI inhibit does not generate the fault mask alarm.

53.4.10 DXX Loop Back

This function is initiated during restart of the DXB if the parameter TNOM_use in RBS DB is already set to ON, otherwise the function is initiated when the parameter is set to ON.

This function controls line loop in the RBS interface PCM-A and PCM-B, to be used for test purposes. The line loop, loops back all timeslots except the TNOM timeslot. The timeslot 0 (for E1) and F bit (for T1) are not looped back either. This loop is referred to as "DXX line loop" or "DXX loop back to interface".

The "DXX line loop" does not necessarily maintain the timeslot integrity. During "DXX line loop", the timeslots do keep their position in the primary rate (1.5 or 2 Mbit/s) frame. Hence, incoming timeslot 17 has to be outgoing timeslot 17.

The delay in the RBS can be different for different timeslots. Hence, timeslots that come in to the RBS in the same frame do not have to be in the same frame when they leave the RBS.

The "DXX line loop" is controlled from DXX individually for PCM-A and PCM-B. The loop is possible to set with a timeout value to release the specific loop. The timeout value is between 1 and 65 000 minutes, in steps of 1 minute.

Both CSU line loop back and CSU payload loop back have higher priority than the DXX line loop. This means that the DXX loop will be suspended when CSU loops (PLB or LLB) is activated. When CSU loop is deactivated, the DXX loop is resumed again.

53.4.11 DXX Node Inventory

This function is initiated during restart of the DXB if the parameter TNOM_use in RBS DB is already set to ON, otherwise the function is initiated when the parameter is set to ON.

This function maintain the RBS node inventory and settings of the transmission interface parameters. The parameters controlled from BSS cannot be modified from DXX.

It is from DXX possible to make a node inventory in order to view the HW and SW status of the DXB, as well as the interface parameter settings.

Node inventory

Hardware types and software types and versions (revisions) can be retrieved by request from DXX.

The SW type and version is the type and version for the specific DXX support software (not for the RBS software).

The HW type inventory include RBS-E1 and RBS-T1.

Transmission interface parameter settings

It is also possible from DXX to get the parameter settings for the transmission interface in the RBS.

The parameter settings that can be fetched are:

- Status of TS0 Sa bits "1" or "0".
 - CRC4 ON or OFF.
 - TN O&M timeslot allocation.
 - Type of interface selected. The interface options are: E1 long-haul, E1 short-haul, T1 long-haul, T1 short-haul, and E1 external HDSL modem.
- Alarm fault filter parameters (see Section 53.4.9 on page 450).
- Performance limit parameters (see Section 53.4.8 on page 447).

53.4.12 Administration of TNOM Generic Functions

The TNOM generic functions are administrated from the OMT by use of the parameters TNOM_use, TNOM_timeslot and TNOM_nodeid.

Application Parameters

TNOM allocation

The parameter used for the Transport Network O&M Timeslot allocation is:

TNOM_use

The valid range of the parameter is:

ON (Auto)

OFF

TNOM timeslot

The parameter used for the Transport Network O&M Timeslot allocation is:

TNOM_timeslot

The valid range of the parameter is:

1–31 for E1

1–24 for T1

TNOM node Id

The parameter used for the Transport Network O&M Node Id allocation is:

TNOM_nodeid

The valid range of the parameter is:

1–65534

The parameters can be modified from the OMT. The parameter TNOM_nodeid can be modified from DXX as well. The new settings are activated immediately.

53.4.13 Administration of DXX Specific Functions

The DXX specific functions are maintained via the interface RBS2000–DXX O&M.

Application Parameters

The parameters used for the Node identity function are handled by:

Object 50 (SUBRACK_INVENTORY)

The parameters used for the Node access control are handled by:

Object 44 (NAC_OBJECT)

The parameters used for the Real time control function are handled by:

Object 44 (RTC_OBJECT)

The parameters used for the Current alarm report are handled by:

Object 6 (CURRENT _ALARMS)

Object 40 (SUBRACK_STATE)

Object 41 (NODE_STATE)

The parameters used for the Alarm history report are handled by:

Object 7 (ALARM_HISTORY)

The parameters used for the G.821 performance report are handled by:

Object 23 (G.821_OBJECT)

The parameters used for the Fault mask function are handled by:

Object 27 (FLM_OBJECT)

Object 228 (IFM_OBJECT)

The parameters used for the Loop back function are handled by:

Object 227 (LL_OBJECT)

Object 226 (CONTROLS_TIMEOUT)

The parameters used for the Node inventory function are handled by:

Object 2 (UNIT_IDENT)

Object 17 (INTERFACE_LOCKING)

Object 18 (INTERFACE_MODULE)

Object 50 (SUBRACK_INVENTORY)

Object 230 (HDLC_MODE)

Object 240 (TS0B4..B8_OBJECT)

Object 243 (TS0B1_OBJECT)

53.4.14 DXX Protocol Handling

This function is initiated during restart of the DXB if the parameter TNOM_use in RBS DB is already set to ON, otherwise the function is initiated when the parameter is set to ON.

The DXX protocol is implemented as four layers in the ISO OSI layer model, layer 1, 2, 3 and 7. These layers correspond to physical link layer, data link layer, network layer, and application layer respectively.

A message that is received at PCM-A in RBS is processed according to layer 1, 2 and 3. In layer 3, the destination node id is housed. If the current RBS is the destination node, the message is sent to layer 7. If the RBS is in topology "Cascaded chain" and not the destination node, the message is sent to the next RBS via PCM-B. The same is valid in the other direction receiving data on PCM-B.

Fault handling

- Layer 2 (Data link layer)

Faults in data within the data link layer are handled in accordance with the ITU-T specification X.25. [X.25].

- Layer 3 (Network layer)

Faults in data within the network layer are checked regarding to fixed header values, data length and data check sum. Faulty messages are discarded. New messages will be sent from NMS based on time-outs in its application layer.

- Layer 7 (Application layer)

Faults in data within the application layer are handled according to the following:

- An RO-Reject is sent from RBS to DXX (an agent to a manager) if the command is not reasonable enough to give either an RO-Result or an RO-Error. The fault status can be one or more of the following: Parameter error, Context error, Functional error or Unknown object.
- An RO-Reject is sent from RBS to DXX (an agent to a manager) if the command is reasonable enough to give an answer but when at least one of the operation is not OK.

53.5 Operational Conditions

53.5.1 Operation and Maintenance

Maintenance data such as enabling of the TNOM function, selection of timeslot for the TNOM management channel and selection of node identity can be set by the OMT. This is described within the context of Operation and Maintenance Terminal.

The values of the node identity can also be set by the NMS in DXX.

This page is intentionally left blank

54 BTS Parameter Limitations

This document specifies configurable BTS parameters with limitations compared with the parameter ranges in the Abis O&M IWD. BTS parameters with no limitations compared to the Abis O&M IWD are not stated in this document.

54.1 Purpose and Readers

The purpose is to show BTS parameters with parameter range limitations compared to the Abis O&M IWD.

People involved in the preparation of data transcripts for the BSC are the target group of this specification.

54.2 References

- 6/155 19–HSC 103 12 Uen
Abis O&M Interface, Part II, Procedures
- 5/155 19–HSC 103 12 Uen
Abis O&M Interface, Part I, Model
- 3/1551–APT 210 09 Uen
Translation of Abis O&M IWD Parameters - BSC Command Parameters

54.3 Parameters

The parameters listed in this document are extracted from the Data Elements listed in the Abis O&M IWD document (see ref. 1). This document states the BTS parameters with parameter range limitations compared with the Abis O&M IWD.

For each parameter in the list, the range supported by the BTS and the Abis O&M IWD is stated.

All coding in the document is in hexadecimal (hex) representation if nothing else is stated.

Note: See reference 3 for BSC Commands.

54.3.1 Accordance Indication

BTS-supported value range:

AIP: 0 – 1, 3

IWD-defined value range: 0 – 3

54.3.2 Alarm Status Type

BTS-supported value range:

Alarm status type: 1

IWD

IWD-defined value range: 0 – 1

54.3.3 BS_AG_BLKES_RES

BTS-supported value range:

BS_AG_BLKES_RES: 0 – 1

IWD-defined value range: 0 – 7

54.3.4 CON Connection List

BTS supported value range:

| | | |
|-----|---|---|
| y | | 0 – 12 |
| mi | | 2 – 13 |
| CCP | | |
| | CCP number | 256, 260, ... 348 |
| | Reserved | 0 – 255, 257 – 259, 261 - 263, ... 349 – 1023 |
| Tag | CP gives deconcentrated inlet/outlet | 0 |
| | CP gives concentrated inlet/outlet and Tag=sequential number of CG within Input Concentration Map | 1 – 12 |

IWD defined value range:

| | | |
|-----|---|-------------------------------|
| y | | 0 – 16 |
| mi | | 2 – 17 |
| CCP | | |
| | CCP number | 0, 4, ... 1020 |
| | Reserved | 1 – 3, 5 – 7, ... 1021 – 1023 |
| Tag | CP gives deconcentrated inlet/outlet | 0 |
| | CP gives concentrated inlet/outlet and Tag = sequential number of CG within Input Concentration Map | 1 – 16 |

54.3.5 Extended Range Indicator

BTS-supported parameter range:

ERI: 0 (extended range off)

IWD-defined value range: 0 – 1

54.3.6 External Condition Map Class 1

BTS-supported value ranges:

LAPD Q CG: 0

| | |
|--------------------------|-------|
| L/R TI: | 0 – 1 |
| L/R SWI: | 0 – 1 |
| TRA: | 0 – 1 |
| PCM SYNC: | 0 – 1 |
| EXT SYNC: | 0 |
| IWD-defined value range: | 0 – 1 |
| LMT: | 0 |

54.3.7 External Condition Map Class 2

BTS-supported value ranges:

| | |
|--------------------------|-------|
| RBS DOOR: | 0 – 1 |
| LAPD Q CG: | 0 |
| EXT SYNC: | 0 |
| PCM SYNC: | 0 – 1 |
| IWD-defined value range: | 0 – 1 |

54.3.8 File Relation Indication

BTS-supported value ranges:

| | |
|--------------------------|-------|
| Other state: | 0, 3 |
| IWD-defined value range: | 0 – 3 |

Note: There are limitations for specific combinations of current state and other state.

54.3.9 FN Offset

FN (Frame Number) Offset must be equal for all TSs within a TRX. Configuration of FN Offset on one TS will also reconfigure all previously configured TSs on that TRX, provided that no TS within the TRX is enabled.

BTS-supported value range:

| | |
|--------------------------|-----------------------------------|
| FN offset: | 0 – 1023 (03FF _(hex)) |
| IWD-defined value range: | 0 – 1325 (052D _(hex)) |

54.3.10 Frequency List

BTS-supported value range:

| | |
|-----------------|---|
| ARFCN, 900 MHz: | 1 – 124 _(dec) (option 1) |
| | 0 – 124, 975 – 1023 _(dec) (option 2) |
| | 0 – 54, 955 – 1023 _(dec) (option 3) |

Note: Option 3 above is only valid for the RBS 2000 Macro system.

ARFCN, 1800 MHz: 512 – 885_(dec)

ARFCN, 1900 MHz: 512 – 810_(dec)

Note: Valid 900 MHz "option" is dependent on hardware configuration.

IWD-defined value range:

ARFCN, 900 MHz: 0 – 124, 975 – 1023, 955–974_(dec)

Note: The value range above is only valid for the RBS 2000 Macro system.

ARFCN, 1800 MHz: 512 – 885_(dec)

ARFCN, 1900 MHz: 512 – 810_(dec)

54.3.11 Frequency Specifier RX

BTS-supported value range:

ARFCN, 900 MHz: 1 – 124_(dec) (option 1)
 0 – 124, 975 – 1023_(dec) (option 2)
 0 – 54, 955 – 1023_(dec) (option 3)

Note: Option 3 above is only valid for the RBS 2000 Macro system.

ARFCN, 1800 MHz: 512 – 885_(dec)

ARFCN, 1900 MHz: 512 – 810_(dec)

Note: Valid 900 MHz "option" is dependent on hardware configuration.

IWD-defined value range:

ARFCN, 900 MHz: 0 – 124, 975 – 1023, 955–974_(dec)

Note: The value range above is only valid for the RBS 2000 Macro system.

ARFCN, 1800 MHz: 512 – 885_(dec)

ARFCN, 1900 MHz: 512 – 810_(dec)

54.3.12 Frequency Specifier TX

BTS-supported value range:

ARFCN, 900 MHz: 1 – 124_(dec) (option 1)
 0 – 124, 975 – 1023_(dec) (option 2)
 0 – 54, 955 – 1023_(dec) (option 3)

Note: Option 3 above is only valid for the RBS 2000 Macro system.

ARFCN, 1800 MHz: 512 – 885_(dec)

ARFCN, 1900 MHz: 512 – 810_(dec)

Note: Valid 900 MHz "option" is dependent on hardware configuration.

IWD-defined value range:

ARFCN, 900 MHz: 0 – 124, 975 – 1023, 955–974_(dec)

Note: The value range above is only valid for the RBS 2000 Macro system.

ARFCN, 1800 MHz: 512 – 885_(dec)

ARFCN, 1900 MHz: 512 – 810_(dec)

54.3.13 IS Connection List

BTS-supported value range:

ICP: 4 – 127_(dec)
 132 – 351_(dec)
 512 – 583_(dec)
 640 – 711_(dec)

CI: 1 – 72_(dec)

The IWD-defined value ranges:

ICP: 0 – 1023_(dec)

CI: 1 – 255_(dec)

Note: There are limitations for specific combinations. For more information see the figure in appendix.

54.3.14 Local Access State

BTS-supported value range:

Local Access State parameter: 0

IWD-defined value range: 0 – 1

54.3.15 MO Identifier

Table 124 BTS-supported/IWD-defined value range

| MO class | BTS-supported value (hex) | | IWD-defined value (hex) | |
|----------|---------------------------|-----------------|-------------------------|-----------------|
| | | Instance number | | Instance number |
| TRXC | 01 | 00 – 0B | 01 | 00 – 0F |
| TX | 0B | 00 – 0B | 0B | 00 – 0F |
| RX | 0C | 00 – 0B | 0C | 00 – 0F |

54.3.16 MO StateTable 125 *BTS-supported codes*

| Code | MO State Parameter | Used by MO |
|------|--------------------|---------------------------------------|
| 00 | Reset | CF, IS, TRXC, RX, TF, TS, TX, DP, CON |
| 01 | Started | CF, TRXC |
| 02 | Enabled | IS, RX, TF, TS, TX, DP, CON |
| 03 | Disabled | IS, RX, TF, TS, TX, DP, CON |

IWD-defined value range: 00 – 03

54.3.17 Power**RBS 2000 Macro system**

Note: Only the following macro configurations are supported:
RBS 2101, RBS 2102 and RBS 2202 with configurations
1x2, 2x2, 3x2, CDU-A for 900 MHz, CDU-A with TMA for
1800 MHz and 1900 MHz.

BTS-supported value range.

Nominal power parameters:

900 MHz: 35 – 47, 49¹⁾_(dec)

1800 MHz: 33 – 45, 47¹⁾_(dec)

1900 MHz: 33 – 45, 47¹⁾_(dec)

IWD-defined value range: 0 – 63_(dec)

Note: Only steps by 2 are configurable (from the highest value).

¹⁾ BSC uses this value to activate SW Power Boost (the value does not describe the actual output power). The RBS then uses TX diversity, and configures each transmitter that supports the master-slave configuration to max. power (for example, 47 dec. for Macro 900 MHz). An RBS with Filter Combiner does not support SW Power Boost.

RBS 2000 Micro system

BTS-supported value range.

Nominal power parameters for the RBS 2301 and RBS 2302:

900 MHz: 21 – 33, 35¹⁾_(dec)

1800 MHz: 21 – 33, 35¹⁾_(dec)

1900 MHz: 21 – 33, 35¹⁾_(dec)

Note: Only steps by 2 are configurable (from the highest value).

¹⁾ BSC uses this value to activate SW Power Boost (the value does not describe the actual output power). The RBS then uses TX diversity, and

configures each transmitter that supports the master-slave configuration to max. power (33 dec).

RBS 2000 Small Indoor Radio System

Nominal power parameters for the RBS 2401:

900 MHz: 07 - 19_(dec)

1800 MHz: 09 - 21_(dec)

IWD-defined value range: 0 – 63_(dec)

54.3.18 Result Code

BTS-supported codes:

Wrong state or out of sequence: 02

File error: 03

Fault unspecified: 04

Protocol error: 06

MO not connected: 07

IWD-defined value range: 01 – 0A

54.3.19 TCH Capabilities

BTS-supported value:

Cross Combination Indicator: 127

IWD-defined value range: 0, 127

54.3.20 TF Mode

BTS-supported code:

TF mode parameter: 1 (= stand-alone)

IWD-defined value range: 00 – 02, FF

54.3.21 Receiver Diversity

BTS-supported value range for RBS 2401:

Receiver diversity: 2

BTS-supported value range for other RBSs:

Receiver diversity: 1 - 3

IWD-defined value range: 1 - 3

54.4 Appendix

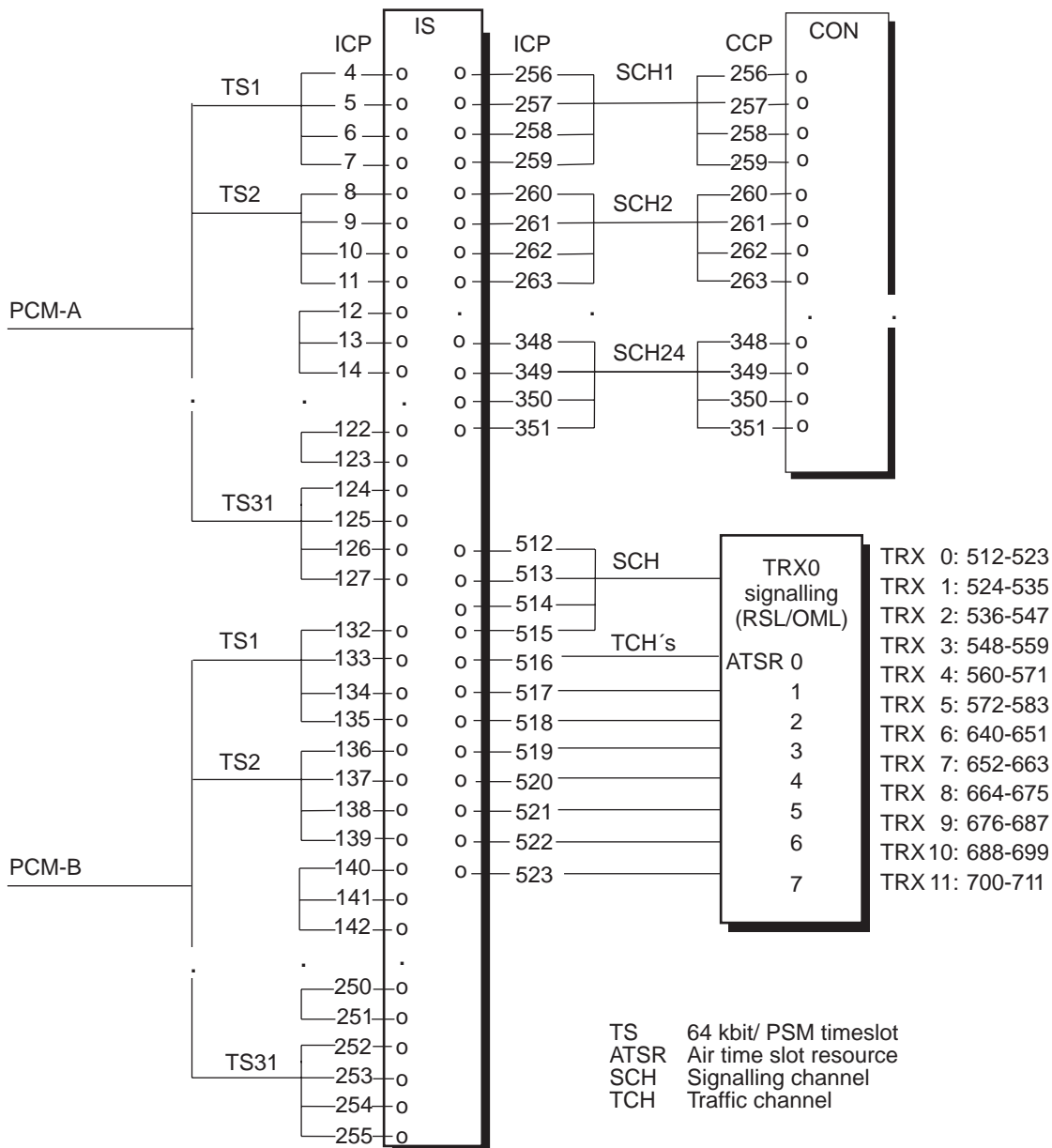

01_0300B

Figure 109 Physical mapping of entities and ICP/CCP

Note: TS25 – TS31 are only applicable for 2048 kbit/s systems.

Each ICP (IS Connection Point) or CCP (CON Connection Point) represents a 16 kbit/s connection point. They are numbered from 4 to 711. A 16 kbit/s channel is established by connecting two ICPs to each other. A 32 or 64 kbit/s signalling channel is established by connecting two or four pairs of consecutive ICPs to each other. The consecutive ICPs must belong to the same TS or SCH.

55 Integrated HDSL for RBS 2302, Optional Feature

This chapter describes the HDSL (High-bit-rate Digital Subscriber Line) modem module for the Ericsson Micro Base Station RBS 2302. HDSL is an optional modem that can be integrated inside the extended installation box door in the mounting base for RBS 2302.

In a fast growing microcell network with a high number of sites, the cost and the availability of transmission for the BTS to BSC communication becomes a very important factor. Efficient usage of the transmission resources coupled with the flexibility to use different common transmission media is a key factor.

By use of the integrated HDSL transmission it is possible to connect the RBS 2302 to physical twisted copper pairs from a BSC or transmission terminal for the A-bis interface. The distance can be longer than with traditional (HDB3) line terminals. The usage of repeaters will then be reduced, which means lower transmission costs. Integrated HDSL also means easier to find sites. This makes the installation easier and the sites will be more landlord friendly. The integrated HDSL module can be used towards other RBS 2302, DXX nodes and stand-alone modems.

55.1 General Description

The RBS 2302 HDSL module is an ETSI compatible HDSL modem module for E1, with several proprietary functional modes added to it. The module is used exclusively in the Ericsson Micro Base Station RBS 2302 environment. The module provides a point-to-point copper pair access from the RBS 2302 to another RBS 2302, from the RBS 2302 to a modem or from the RBS 2302 to a DXX node with a HCE module assembled in it. Using the ETSI compliant modes of the module the RBS 2302 can with reduced functionality also be connected to another vendors HDSL modems.

The module consists of two independent 2 Mbit/s 1-P (one pair) ETSI HDSL modems on a single PCB, both modems having their own G.704 DTE interface towards the base station. The modems can also be connected together and configured in such a way that they form a single 2Mbit/s 2-P HDSL modem. This HW circuitry enables several functional modes, which is covered later in this document.

The HDSL module PCB is assembled inside the extended installation box door of the RBS 2302. Electrically the module replaces the internal transmission cable. It converts the internal PCM-A and/or PCM-B port G.703 interfaces at the radio cabinet into one or two external HDSL connections. One of the PCM-A or PCM-B ports can still be bypassed through the HDSL module. The HDSL signals pass RBS EMC filters.

The bit rate at the G.704 interface is always 2.048 Mbit/s. The bit rate at the line interfaces can be either 2320 kbit/s, 1168 kbit/s or 592 kbit/s. Hence a fractional G.704 mode is also possible, which means that not all the G.704 time slots are sent over the HDSL copper access.

Two independent alarm indication signals are optionally provided to the RBS 2302 when the modem is not connected to DXX manager. These alarms provided by the HDSL module are visible as "RBS external

alarms" at the BSC/OSS. Doing this reduces the number of possible external alarms by two.

When opening the door three LEDs are visible indicating the operating status of the modem. The LEDs are used during installation and fault tracing.

The HDSL module will get its power from the power unit in the radio cabinet.

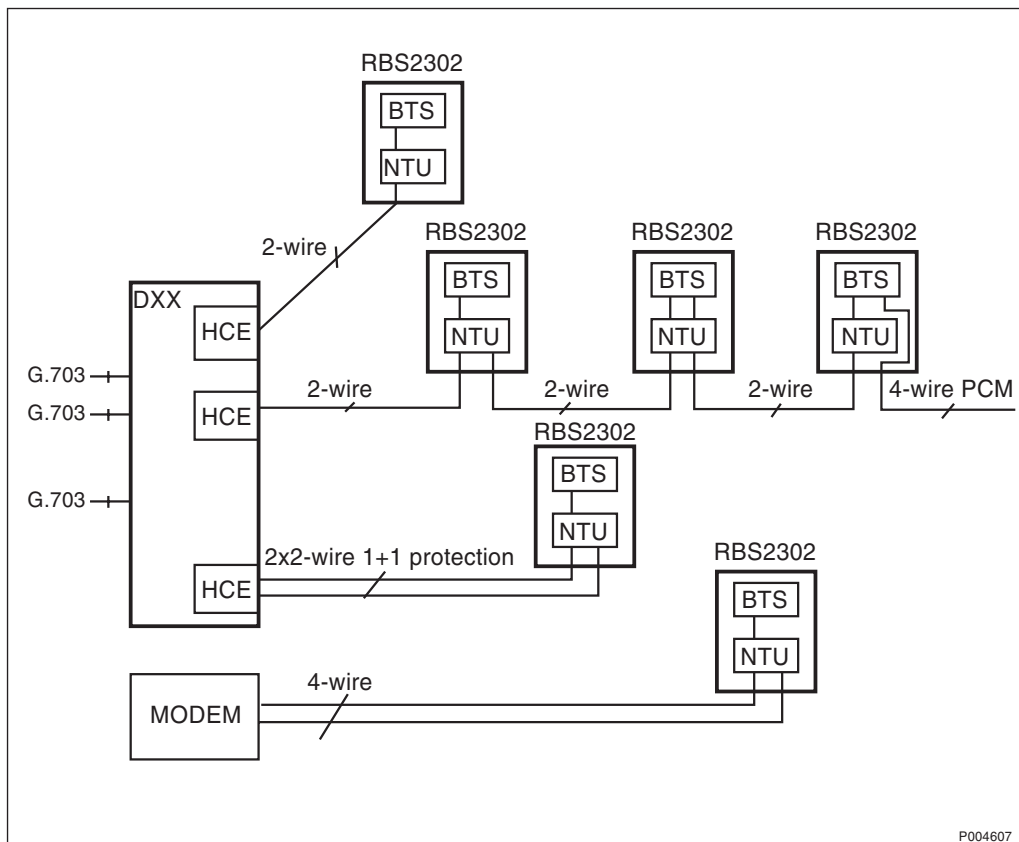

Figure 110 Application examples

Figure 110 on page 466 shows some alternative applications with RBS 2302 including the optional HDSL modem.

55.2 Physical Interface

55.2.1 Line Interface (HDSL)

| | |
|-----------------|--|
| Line bit rates: | 592 kbit/s, 1168 kbit/s and 2320 kbit/s |
| Line code: | Automatic line rate detection in modems that are configured as slaves. In ETSI compatible modes this autorate feature is not in use. |
| Impedance: | 2B1Q, 1-pair or 2-pair connection with echo cancellation |
| Transmit level: | 135 Ω |
| | +13.5 dBm (specified in ETSI TS 101 135) |

| | |
|------------------|---|
| Line monitoring: | <ol style="list-style-type: none"> 1. Carrier detection 2. Received signal level indication 3. Indication of noise margin to 10^{-7} 4. CRC error monitoring on the line (each HDSL link separately) |
| Connector type: | 44-pin high densed D-sub connector (internal RBS connection) |

Line interface is connected to the copper pair via the standard over voltage protection of the RBS 2302.

55.2.2 Data Terminal Equipment Interface (to BTS)

| | |
|------------------|--|
| DTE bit rate: | 2048 kbit/s |
| Interface type: | G.703, (2048 kbit/s); G.704 frame structure |
| Interface code: | HDB3 |
| Impedance: | 120 Ω symmetrical |
| Transmit timing: | Co-directional |
| Connector type: | 44-pin high densed D-sub connector (internal RBS connection) |

Note: The timing on the line is independent from the DTE timing. This means that the DTE timing does not have to be looped although the line timing always is looped. The timing information is passed over the link by a bit stuffing schemes, which has been described in the ETSI TS 101 135 Specification by ETSI. In the receiver side the timing information to be passed towards the DTE is extracted from the HDSL frame stuffing bits, not from the line clock. If used with DXX node the DTE timing has to be locked in both directions to the clock provided by the node.

55.3 Principle Operating Modes

The u-BTS HDSL module has two principal operating topologies, namely point-to-point and cascade (or multi-drop) where the point-to-point topology can further be divided into three operating modes. These principal modes determine the number of the active G.704 interfaces, the number of the active line interfaces (that is, the number of the copper pairs used), the line rates used and the active time slots on the G.704 interface(s).

The mode also determines whether the module is seen as a single HDSL modem or as two independent HDSL modems with their supervision channel cascaded inside the module.

It should be noted that the labelling of the G.704 interfaces and the pairs is fixed. This means that whenever only one G.704 interface is used it is always the interface for PCM-A. When the module is configured in the multi-drop mode the up link G.704 interface is interface PCM-A and the

down link G.704 interface is interface PCM-B. Respectively, when the modem is in 1-pair operation the pair used in the line interface is always pair 1. In 2-pair modes the pair numbering could be selected arbitrarily.

55.3.1 Point-to-Point Topology

1-pair mode

In this mode the module is working as a single 1-P HDSL modem using one G.704 interface. The line rate can be either 2320 kbit/s, 1168 kbit/s or 592 kbit/s. The maximum number of the used time slots is specified by the line rate and is 32, 18 or 9, respectively. If the number of used time slots is less than the maximum allowable number the unused time slots are filled with idle pattern. The circuitry of the other modem is configured to be idle.

Only the first alternative with line rate 2320 kbit/s is ETSI 1-pair compliant in the ETSI modes.

2-pair mode

In this mode the module is working as a single 2-P HDSL modem using one G.704 interface. The line rate can be either 1168 kbit/s or 592 kbit/s on both pairs. The maximum number of the used time slots is specified by the line rate and is 32 or 18 respectively. If the number of used time slots is less than the maximum allowable number the unused time slots are filled with idle pattern.

In ETSI modes the modem will allow the connection on the other pair to be down and still transfer data on the other pair (so called partial mode).

Only the first alternative with line rate 1168 kbit/s is ETSI 2-pair compliant in the ETSI modes.

1+1 protection mode

In this mode the module is working as a single 1-P HDSL modem with line failure protection using one G.704 interface. All the active time slots from the G.704 interface are duplicated to the HDSL frame of the "redundant" pair also to be sent over the line.

In the receive direction the modem uses the normal pair as long as no line failure occurs. If a failure occurs the following procedure will be accomplished:

- a** The modem processor detects the line failure from the six consecutive sync-word errors in the HDSL frame; this phase takes about 100 ms and the data is corrupted during this period.
- b** The data is switched to AIS for 400 ms and during this period the back-up line is selected as the clock source; during this period the clock phase may slide several bits because there may be different propagation delay on the two pairs.
- c** The data is selected to be taken from the back-up line and a normal data transmission continues.

The line rate can be 2320 kbit/s, 1168 kbit/s or 592 kbit/s and is the same on both pairs. The maximum number of the used time slots is specified by the line rate and is 32, 18 or 9, respectively.

This mode is not ETSI compliant.

55.3.2 Multi-Drop (Chain) Mode

In this mode the module is working as two 1-P HDSL parallels modems both using one G.704 interface each. The line rate can be 2320 kbit/s, 1168 kbit/s or 592 kbit/s and may be individually selected in both the modems. The maximum number of the used time slots is specified by the line rate and is 32, 18 or 9 respectively. If the number of used time slots is less than the maximum allowable number, the unused time slots are filled with idle pattern.

The supervision channels of the two modems can be connected in such a way that the channels are in a cascade and form a chain. This way the supervisory information can be passed from the HDSL link of one modem to the HDSL link of the other modem. This chain provides means for the NMS to supervise all the HDSL access links of the base station chain down link from the DXX node. The maximum number of HDSL modules to be cascaded is 8.

55.3.3 ETSI Modes Summarized

In the ETSI modes it is possible to communicate with HDSL modems from other vendors. The interoperability between modems from different vendors works mostly but must be once tested. The ETSI mode supports 1-pair mode with line rate 2320 kbit/s and 2-pair mode with line rate 1168 kbit/s.

In the 2-pair mode the DTE interface can be defined to the following ETSI modes:

- unstructured leased line (2 x 1 Mbit/s asynchronous as strap setting)
- structured leased line (2 x 1 Mbit/s synchronous as strap setting)
- partial operation (2 x 1 Mbit/s partial as strap setting)

1+1 protection mode and Multi-Drop (Chain) mode are not supported in ETSI mode.

55.4 Time Slot Handling in PCM-A and PCM-B

When the line rate on the link is 2320 kbit/s on one pair or 1168 kbit/s on two pairs, the module conveys all the 32 time slots of the G.704 interface over the link. Since the supervision information is not sent inside the data stream, all the time slots remain untouched, and the G.704 interface is fully transparent. If the user (= RBS 2302) wants to calculate the CRC over the link, it can be done without any problems.

If the line rate is 1 x 1168 kbit/s, 2 x 592 kbit/s or 1 x 592 kbit/s, only 18 or 9 time slots are conveyed over the link. The time slots to be sent over the link can be selected freely via the DXX manager. Other time slots are considered as idle time slots. Since the G.704 interface is always 2048 kbit/s, the missing time slots must be generated on the

receive side somehow. The module simply fills the idle time slots with the idle pattern which can be programmed by the user via NMS but which is 01010100 (54h) by default. Since the user via NMS can freely select the active time slots, the module knows which time slots must be filled with the idle pattern in the receiver.

In default configurations and in applications without DXX manager, the time slot assignment (at the user interface) is shown in Table 126 on page 470 below for the different line configurations.

Table 126 Default time slot mappings in proprietary DXX mode and ETSI mode

| Line Operation Mode | Data Rate | | | | Line 1 Time Slots | Line 2 Time Slots |
|---|-----------|----|----|----|--------------------------------------|-----------------------------------|
| | IF | PL | L1 | L2 | | |
| Ericsson DXX-1x2M | 32 | 36 | 36 | - | 0, 1, ...,35 | - |
| Ericsson DXX-2x1M | 32 | 36 | 18 | 18 | 0, 2, ...,34 | 1, 3, ..., 35 |
| Ericsson DXX-1x1M | 32 | 18 | 18 | - | 0, 1, ...,17 | - |
| Ericsson DXX-1x1M protected/ backup pair | 32 | 18 | 18 | 18 | 0, 1, ... 17 | 0, 1, ..., 17 |
| Ericsson DXX-2x0.5M | 32 | 18 | 9 | 9 | 0, 2, ...16 | 1, 3, ..., 17 |
| Ericsson DXX-1x0.5M | 32 | 9 | 9 | - | 0, 1, ...,8 | - |
| Ericsson DXX-1x0.5M protected/ backup pair | 32 | 9 | 9 | 9 | 0, 1, ...,8 | 0, 1, ..., 8 |
| ETSI-1x2M | 32 | 32 | 32 | - | 0, 1, ...,31 | - |
| ETSI-2x1M asynchronous/ unstructured | 32 | 32 | 17 | 17 | asynchronous | asynchronous |
| ETSI-2x1M synchronous/structured | 32 | 32 | 17 | 17 | 0, 1, 3, ...15, 16, 18, ...,30 | 0, 2, ..., 16, 17, 19, ..., 31 |
| ETSI-2x1M partial | 32 | 32 | 17 | 17 | 0, 1, 3, ..., 15, 16, 18, ..., 30 | 0, 2, ..., 16, 17, 19, ..., 31 |

Note: IF means time slots in the interface towards the BTS. PL means max. line payload as time slots. L1 and L2 mean corresponding line data rate as time slots. In protected modes the user data is backed up by sending the same data on both lines. The protected line, that is the line which is used primarily to data transfer, can be selected. Protected line selection of a slave NTU always follows the protected line selection of the master LTU.

Note: If the RBS calculates the CRC it has to fill the unused time slots in the transmit side G.704 interface with idle pattern to make the CRC check sum match on the receive side.

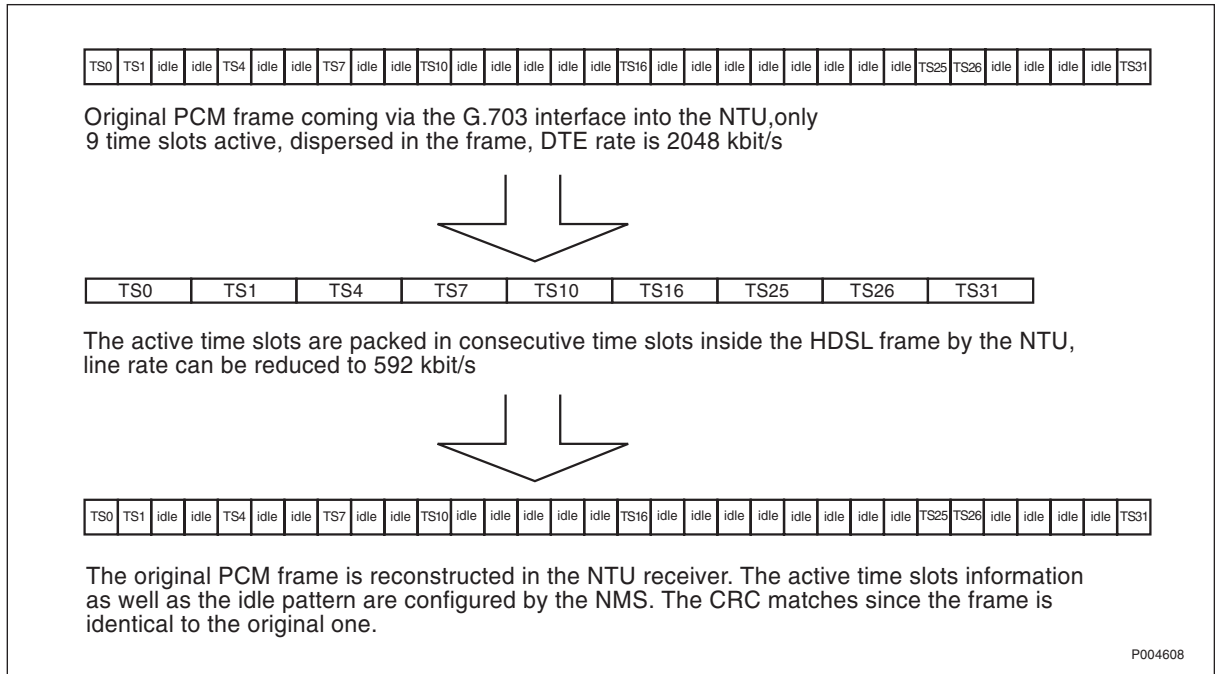

Figure 111 Example of time slots handling at line rates < 2320 kbit/s

55.5 Supervision Channel

The supervision channel is implemented using the ETSI HDSL EOC instead of the proprietary DXX 64 kbit/s supervision channel. The bit rate of the channel is about 2 kbit/s. Since the supervisory channel does not deploy the G.704 interface, that is, it does not alter the bit rate or time slot allocation on the IF it is possible to use other vendors modems together with this RBS 2302 HDSL modem unit. If the modem at the central node or at the other base station is not a RBS 2302 HDSL modem, the data will be transferred normally, but only the supervisory functions lack (possible only in the ETSI compliant modes, that is, point-to-point 1 x 2320 kbit/s and 2 x 1168 kbit/s). In these cases the module (and HCE) will be configured in so called ETSI mode which does not support the described DXX manager functions provided by the EOC channel. The EOC will then be used as described in ETSI TS 101 135.

The control processor in each HDSL modem will sense the supervisory commands coming down link and controls the response to be sent up link. It also conveys the commands meant to other modem in the (possible) chain.

It is not recommended to mix HDSL- and PCM links in the same chain, as the HDSL supervision is not supported over a PCM link.

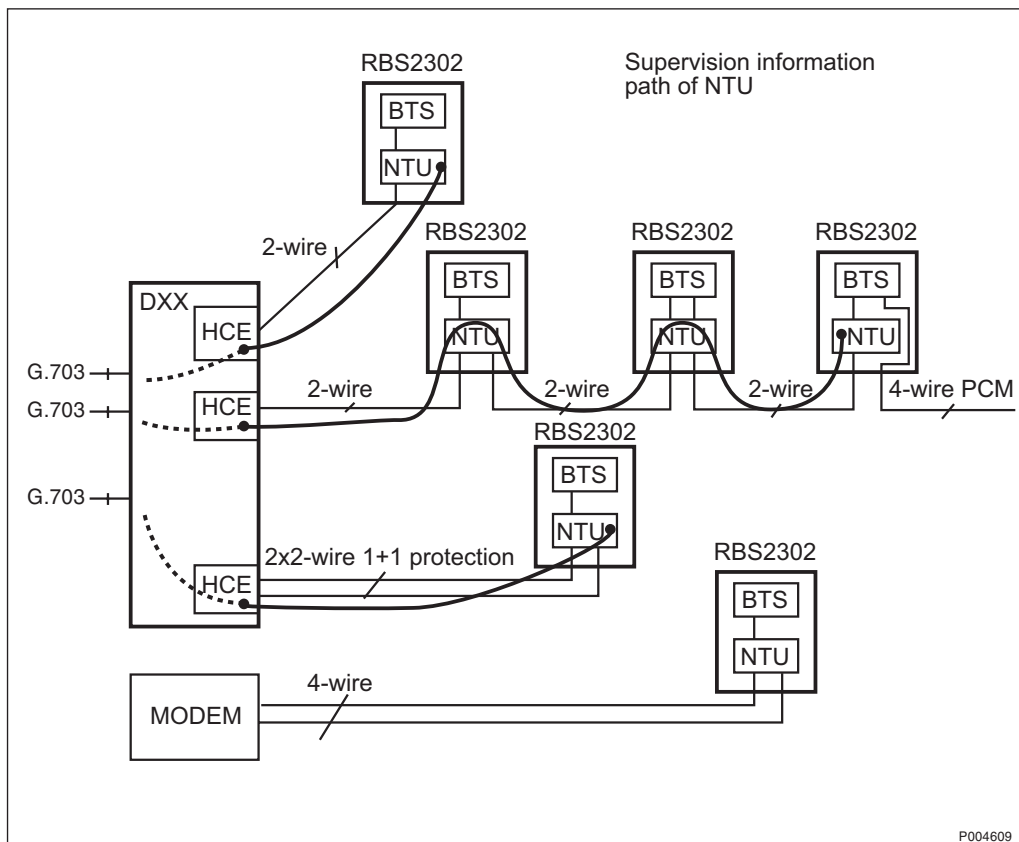

Figure 112 The NMS supervision information path provided by the EOC channel

55.6 Pre-installation and Commissioning

The HDSL module is in factory configured with the default setting for Cascade (chain) mode with line rate 2320 kbit/s and the RBS external alarms 3 and 4 in to be used by the HDSL module.

The HDSL modem module needs to be reconfigured if the default settings are not acceptable for the application where the modem shall be used. If the default settings are acceptable, the modem needs to be interconnected with the BTS cabinet.

Reconfiguration of the modem module is described in the sections below. Preinstallation of the HDSL modem module is usually performed before the RBS is shipped to the RBS site.

The configuration of the Modem module is marked on a label inside the door of RBS.

55.6.1 Replacing the HDSL Links with PCM Links

At Pre-installation one can select whether to establish an HDSL link up link, an HDSL link down link or HDSL links in both directions. The other link is then established with a PCM connection that is directly bypassed from the Radio Cabinet G.703 interface to the external line interface. Choosing one of the three possible connectors in both the line interface (J2, J4 and J6) and the G.703 interface (J1, J3 and J5) of the module makes the choice of configuration. Below is a table that states the link choice as a function of the selected connector:

Table 127 Connector settings for different link choices

| Selected Connectors | Up Link Type | Number of Pairs in Up Link | Down Link Type | Number of Pairs in Down Link |
|---------------------|--------------|----------------------------|----------------|------------------------------|
| J5 and J6 | PCM | 2 (=PCM) | HDSL | 1 or 2 in p-t-p |
| J3 and J4 | HDSL | 1 | HDSL | 1 |
| J1 and J2 | HDSL | 1 or 2 in p-t-p | PCM | 2 (=PCM) |

Default setting: J3 and J4

The 1+1 protection mode selection is independent from this link type selection but is only available in point-to-point modes.

55.6.2 Strapping

The user interface consists of a strapping bank with which the principal operating topologies of the module can be configured. Also some other parameters are given their default value with these strappings. Although the NMS takes care of the configuring and monitoring of the module these strappings are needed for power-up situations and for some exceptional situations (like when RBS bypasses its HDSL module by relays). Also some information is needed for the applications where DXX node is not used at the other end (for example two u-BTS HDSL modules at both ends of the link).

The noise margin of the two transmission pairs ("To low noise margin on pair 1" "To low noise margin on pair 2" respectively) are supervised, and can be reported to the RBS external alarms 3 and 4. When the modem is connected to the NMS, the alarms can be inhibited from reporting to RBS.

The following functions can be set as parameters with the DIP switch:

- Topology mode (point-to-point/chain)
- Modem role in point-to-point mode (HDSL slave/master)
- Line rate in point-to-point ETSI compliant mode
- Line rate in point-to-point DXX proprietary mode
- The running number of the RBS (=module) if configured in a chain
- HDSL operation in point-to-point mode (DXX proprietary or ETSI)
- 1 Pair /2 Pair in point-to-point mode
- Protection in point-to-point mode
- Usage of module generated alarms (internal for HDSL or External)

55.6.3 Mounting of Module inside the "Door"

The picture below describes briefly how the HDSL modem module is mounted in the RBS door. The module is fixed into the door with 10 screws.

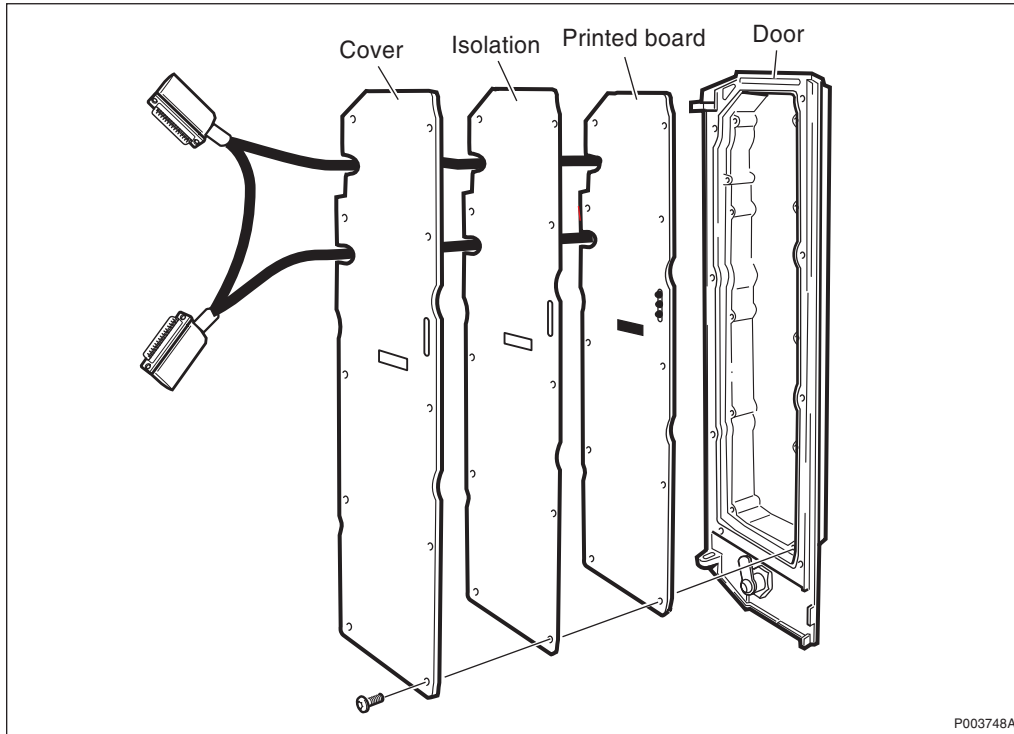

Figure 113 Mounting of HDSL Modem Module in the RBS door

55.7 Product Application Information

55.7.1 Summary on Product Mode features

Table 128

| Mode | 1-pair | 2-pair | 1+1 Protection | Multi-drop |
|----------------------|--------|--------|----------------|------------|
| Number of pairs used | 1 | 2 | 2 | 2 |
| Active DTE IFs | 1 | 1 | 1 | 2 |
| Line rates kbit/s | | | | |
| 592 | • | • | • | • |
| 1168 | • | • | • | • |
| 2320 | • | • | • | • |

The appended figures describe the operating modes and the usage of PCM links vs. HDSL links.

55.7.2 HDSL Technical Specification

| | |
|---------------------|---|
| Device name: | NTU-E2P, Network Terminating Unit for ETSI (2 pair) |
| DTE bit rate: | 2048 kbit/s |
| DTE interface type: | G.703, 120 Ω balanced |
| DTE signal coding: | HDB3 |
| DTE timing: | Co-directional |
| Line rates: | 2320 kbit/s, 1168 kbit/s, automatic rate detection at slave modems |
| Line code: | 2B1Q |
| Impedance: | 135 Ω |
| Transmit level: | +13.5 dBm (at 135 Ω resistive load) |
| Max. cable length: | > 3.4 km @ 2320 kbit/s line rate ¹⁾ > 5.0 km @ 1168 kbit/s line rate ¹⁾ > 6.0 km @ 592 kbit/s line rate ¹⁾ |
| Input voltage: | +7 VDC (supply from the radio cabinet) |
| Power consumption: | app. 3.5 W @ NTU |

¹⁾ The max. cable length values refer to a 0.5 mm 40nF/km cable with $10\mu\text{V}/\sqrt{\text{Hz}}$ ETSI shaped noise. In the User's Guide, values for other noise levels and 0.4 mm cable can be found.

55.7.3 Normative General HDSL Standards

Meets ETSI HDSL (TS 101 135, June 1995) performance requirements for 2-pair 2B1Q-systems in functional modes using line rate 1168 kbit/s. Meets ETSI TS 101 135 performance requirements for 1-pair 2B1Q-systems in functional modes using line rate 2320 kbit/s.

The functional modes using line rate 592 kbit/s will meet the ETSI TS 101 135 performance requirement with an extensive margin.

55.7.4 Mechanical Dimensions

Size

The size of the door including the HDSL modem;

Size (H x W x D): 488 x 114 x 44 mm

Weight

Total weight of the optional door including the HDSL modem is less than 1.7 kg.

55.8 Example A

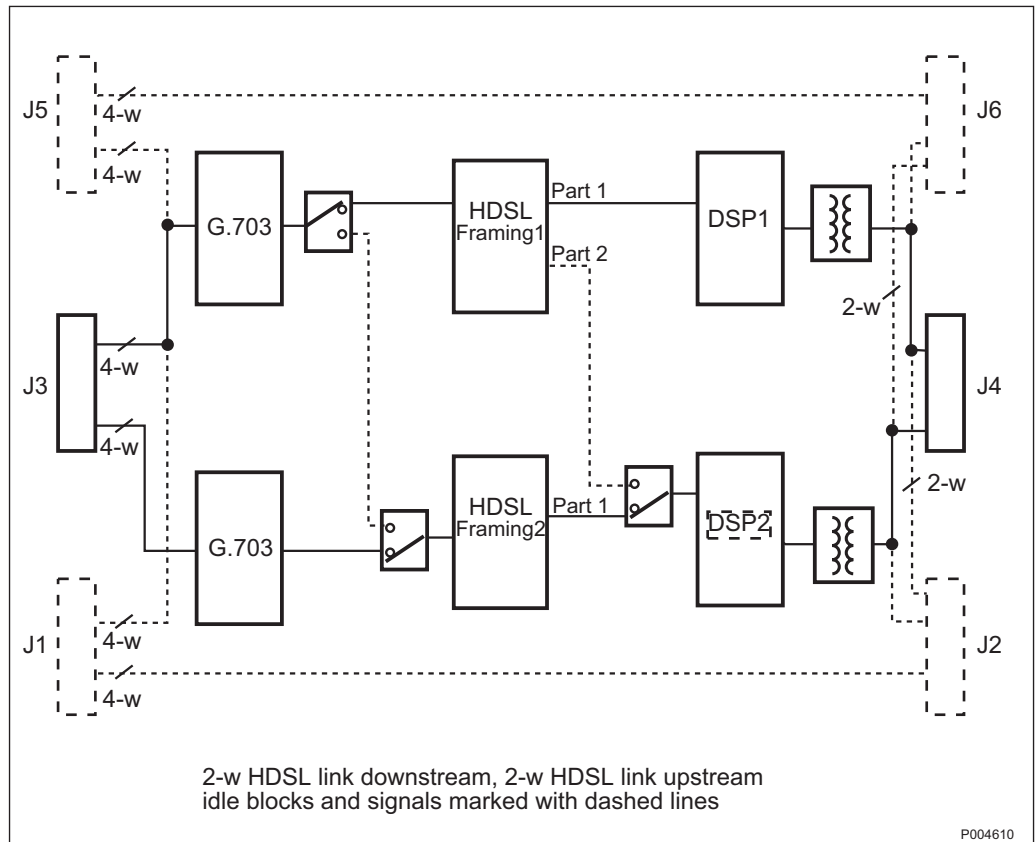

Figure 114

55.9 Example B

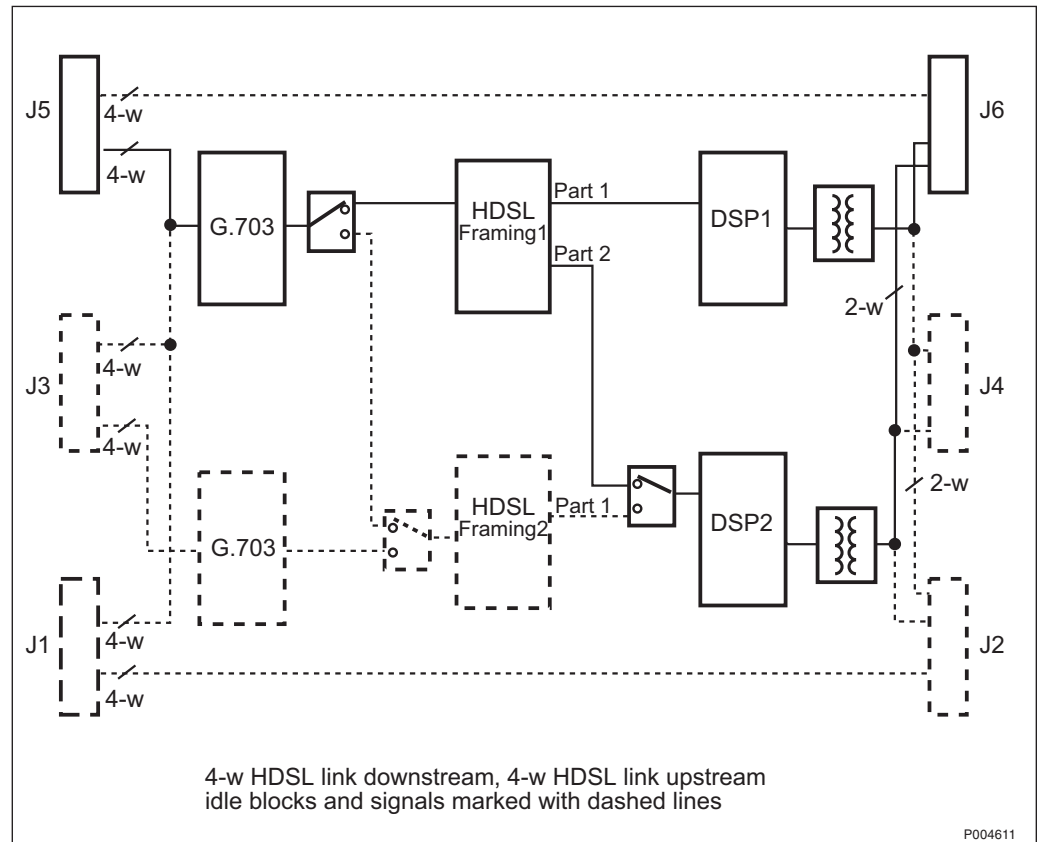

Figure 115

55.10 Example C

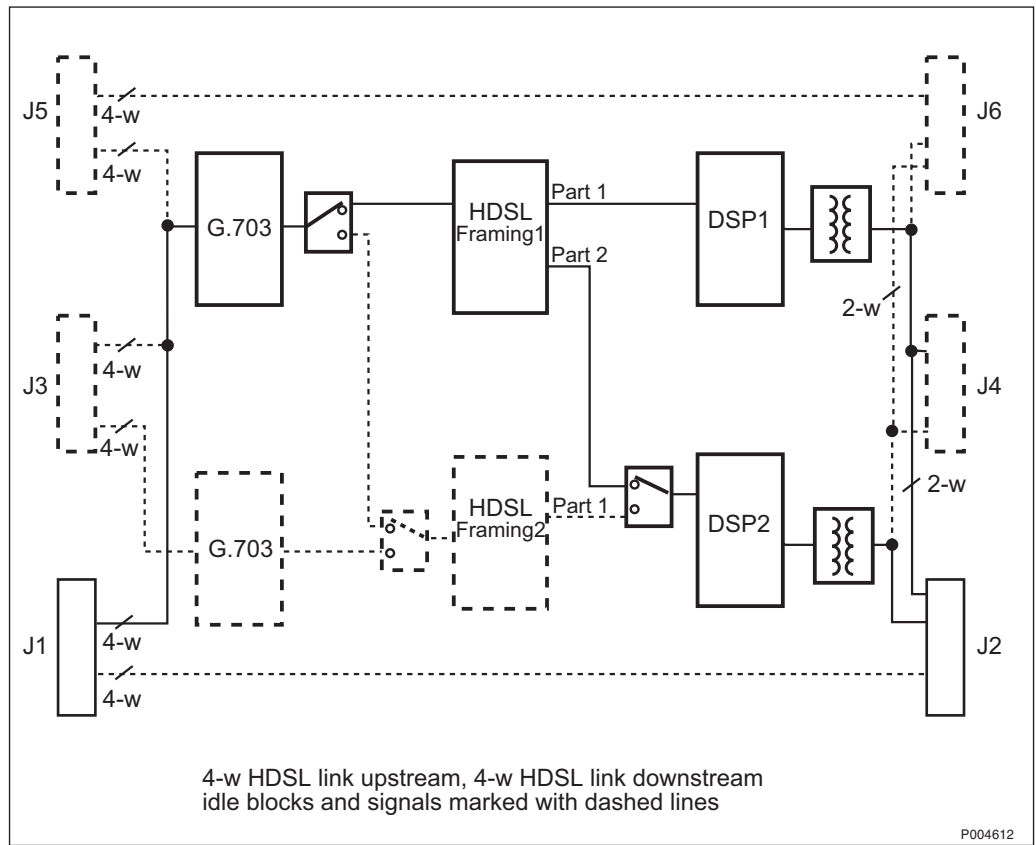

Figure 116

55.11 Example D

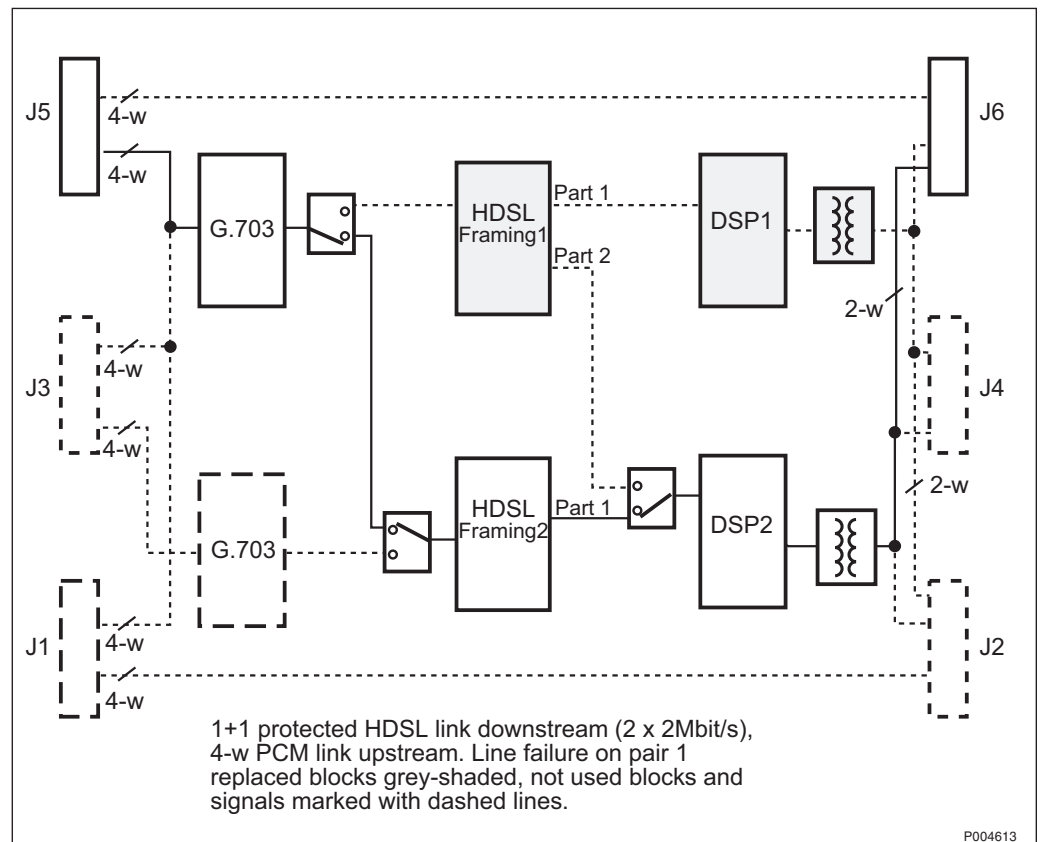

Figure 117

55.12 Acronyms and Abbreviations

| | |
|------|---|
| 2B1Q | 2-binary, 1-quaternary line code |
| 1-P | One Pair connection with echo cancellation (=2 wires) |
| 2-P | Two Pair connection with echo cancellation (=4 wires) |
| AIS | Alarm Indication Signal |
| BSC | Base Station Controller |
| BTS | Base Transceiver Subsystem |
| CRC | Cyclic Redundancy Check |
| dB | Decibel |
| dBm | Decibel per 1 milliwatt |
| DC | Direct Current |
| DTE | Data Terminal Equipment |
| E1 | G.703, 2048 kbit/s |

| | |
|--------|---|
| EMC | Electromagnetic Compatibility |
| EN | European Norm |
| EOC | Embedded Operations Channel |
| ETSI | European Telecommunication Standard Institute |
| GSM | Global System for Mobile Communications |
| HCE | HDSL Central Equipment |
| HDSL | High bit rate Digital Subscriber Line |
| HDB3 | High Density Binary 3 (line code) |
| kbit/s | kilobits per second |
| LED | Light Emetting Diod |
| LVD | Low Voltage Directive |
| Mbit/s | Megabits per second |
| mm | millimetre |
| MTBF | Mean Time Between Failures |
| NMS | Network Management System |
| NTU | Network Terminating Unit |
| O&M | Operation and Maintenance |
| OSS | Operating Support System |
| PCM | Pulse Code Modulation |
| RBS | Radio Base Station |
| TS | Technical Specification |
| V DC | Volts, Direct Current |
| W | Watt |

56 Glossary

This glossary lists abbreviations and acronyms used in texts dealing with RBS 2301 and 2302. Some basic terms and acronyms needed for cross-references are included in the list.

In the RBS manuals, terminology defined by GSM is used together with terms related to Ericsson and the CME 20 and CMS 40 projects.

Terms and Abbreviations

An arrow -> is used to indicate a reference to another entry in this list.

| | |
|---------------|---|
| AAU | Active Antenna Unit |
| Abis | GSM interface standard defining attributes of the communication between BSC and BTS. |
| AC | Alternating Current |
| A/D converter | Analog to Digital converter |
| AGW | Abis Gateway |
| AIS | Alarm Indication Signal |
| ALBO | Automatic Line Build Out |
| ALPU | Antenna Lightning Protection Unit |
| AO | Application Object |
| ARAE | Antenna Related Auxiliary Equipment |
| ARFCN | Absolute Radio Frequency Channel Number |
| ARP | Antenna Reference Point |
| ASIC | Application Specific Integrated Circuit |
| Astra | ASIC in the TRU |
| AU | Antenna Unit GSM 900 = CEU + Passive Antenna GSM 1800/1900 = AAU |
| BCCH | Broadcast Control CHannel Downlink only broadcast channel for broadcast of general information at a base station, on a base station basis. |
| BER | Bit Error Rate |
| BSC | Base Station Controller |

| | |
|---------------------|--|
| | GSM network node for control of one or more BTSs. |
| BSCSim | Base Station Controller Simulator |
| BSS | Base Station System |
| | GSM network logical unit comprising one BSC and one or more BTSs. |
| BTS | Base Transceiver Station |
| | GSM network unit operating on a set of radio frequency channels in one cell. |
| Burst | A portion of digital information, the physical content, that is transferred within the time interval of one time slot. |
| CAN | Canada |
| Cabinet | The physical housing of a base station. |
| Cascade connections | Connection of several cabinets by the PCM cable. Similar to serial connection. -> Cascading |
| Cascading | Connection of several cabinets by the PCM cable. Similar to serial connection. -> Cascade connections |
| CCCH | Common Control CHannel Channel combining the following common control channels: PCH Paging CHannel RACH Random Access CHannel AGCH Access Grant CHannel |
| CDU | Combining and Distribution Unit |
| Cell | An area of radio coverage identified by the GSM network by means of the cell identity. |
| CEU | Coverage Extension Unit |
| CF | Central Functions |
| Channel | The common term channel denotes the virtual connection, consisting of physical and logical channels between BSS and MS, during a call in progress. -> Logical Channel -> Physical Channel |

| | |
|---------------------|---|
| Channel Combination | A physical channel on an air interface carries a defined set of logical channels. |
| Channel group | A channel group is a group of dedicated logical channels to a specific MS. |
| CM | Common Mode |
| CME 20 | Cellular Mobile Europe - CME 20 Ericsson digital land mobile telecommunication system based on the GSM standards. - CME 201 Ericsson GSM system comprising Ericsson equipment only. |
| CMRU | Central Main Replaceable Unit. Main RU. The RBS is physically connected to the Base Station Controller (BSC) via the CMRU. There is only one CMRU in each RBS. |
| CMS 40 | Cellular Mobile System Ericsson digital land mobile telecommunication system based on the Joint Technical Committee (JTC) specification for PCS 1900. |
| CPI | Communication and Power Interface |
| CPU | Central Processing Unit |
| CS | Coding Scheme |
| CSA | Canadian Standards Association |
| CSES | Consecutive Severely Errored Second |
| CSU | Customer Service Unit |
| Dannie | ASIC in the TRU |
| dB | decibel |
| DB | DataBase |
| DC | Direct Current |
| DCC | Digital Cross Connector |
| DCS | Digital Communication System International standard for 1800 MHz based on the GSM standard. |
| DIP | DIgital Path |

| | |
|----------|--|
| | The name of the function used for supervision of the connected PCM lines. |
| Dixie | ASIC in the TRU |
| DM | Degraded Minute |
| DM | Differential Mode |
| DMRU | Distributed Main Replaceable Unit If a Main RU is subordinated to the CMRU, it is said to be distributed. |
| Downlink | Signalling direction, from the system to the MS |
| DP | Distribution Panel |
| DPX | Duplexer |
| DS1 | Digital Signal Level 1 (1544 kbit/s) |
| DSP | Digital Signal Processor |
| DTF | Distance To Fault |
| DUT | Device Under Test |
| DXB | Distribution Switch Board |
| DXX | Ericsson Cellular Transmission System including NMS |
| E1 | Short for G.703 2048 kbit/s PCM link |
| EEPROM | Electrically Erasable Programmable Read-Only Memory |
| EIRP | Effective Isotropic Radiated Power |
| EMC | Electro Magnetic Compatibility |
| ES | Errored Second |
| ESD | ElectroStatic Discharge |
| ETS | European Telecommunication Standard |
| EXT | External |
| FCC | Federal Communications Commission |
| FDL | Facility Data Link |
| FDU | Feeder Duplexer Unit |
| FS | Function Specification |

| | |
|----------|--|
| FSC | Field Support Centre |
| FU | Filtering Unit |
| GPRS | Global Package Rating System |
| GS | General Specification |
| GSM | Global System for Mobile communications International standard for a TDMA digital mobile communication system. Originally, GSM was an abbreviation for Groupe Special Mobile, which is a European mobile telecommunication interest group, established in 1982. |
| GSM 900 | GSM system 900 MHz (generic) |
| GSM 1800 | (GSM-based) Digital Communication System 1800 MHz (generic) |
| GSM 1900 | (GSM-based) Digital Communication System 1900 MHz (generic) |
| HDLC | High level Data Link Control |
| HDSL | High bit rate Digital Subscriber Line |
| HISC | Highway Splitter Combiner |
| HLIN | High Level IN |
| HLOUT | High Level OUT |
| HW | HardWare |
| HWU | HardWare Unit An HWU consists of one or more SEs. An HWU is a functional unit within the RBS. The HWU is either active (equipped with a processor) or passive (without processor). |
| ID | IDentification |
| IDB | Installation Data Base |
| IEC | International Electric Commission |
| IF box | Inter Face Box |
| INT | Internal |
| IS | Interface Switch |
| I1A | Internal Fault Map Class 1A |
| I1B | Internal Fault Map Class 1B |

| | |
|---------------------|--|
| I2A | Internal Fault Map Class 2A |
| JTC | Joint Technical Committee |
| LAN | Local Area Network |
| LAPD | Link Access Procedures on D-channel LAPD is the data link layer (layer 2) protocol used for communication between the BSC and the BTS on the Abis interface. Abis layer 2 is sometimes used synonymously with LAPD. |
| LBO | Line Build Out |
| LED | Light Emitting Diode |
| LLB | Line Loop Back |
| LNA | Low Noise Amplifier |
| Local bus | The local bus offers communication between a central main RU (DXU) and distributed main RUs (TRU and ECU). |
| Local mode | When the RU is in RU mode Local it is not prepared for BSC communication. |
| Local/Remote switch | Using the Local/Remote switch, an operator orders the RU to enter Local or Remote mode. |
| LOF | Loss Of Frame |
| Logical Channel | A logical channel represents a specified portion of the informationcarrying capacity of a physical channel. GSM defines two major categories of logical channels: TCHs Traffic CHannels, for speech or user data CCHs Control CHannels, for control signalling. -> Physical Channel -> Channel Combination |
| Logical RU | A unit which can be referred to, but is not a single physical unit. There are three different kinds of logical RUs: 1. Buses 2. Antennas |

| | |
|---------------|--|
| | 3. Environment |
| LOS | Loss Of Signal |
| LVD | Low Voltage Directive |
| LVF | Low Voltage Filter |
| MADT | Mean Accumulated DownTime |
| Main RU | A main replaceable unit is a replaceable unit that contains one or more processors, to which software can be downloaded from the BSC. |
| MCB | MultiCasting Box |
| MHS | Modification Handling System Ericsson trouble report database |
| MMI | Man-Machine Interface |
| MO | Managed Object |
| MRT | Mean Repair Time |
| MS | Mobile Station |
| MTBF | Mean Time Between Failure |
| MTBCF | Mean Time Between Catastrophe Failure |
| NCS | National Colour System |
| NMS | Ericsson Network Management System in DXX |
| Nominal Power | The nominal power is the power level defined when configuring the transceiver. |
| O&M | Operation and Maintenance General term for activities such as configuration, utilization of channels (frequency bands), cell planning, system supervision, hardware and software maintenance, subscriber administration, etc. |
| OMC | Operation and Maintenance Centre |
| OMT | Operation and Maintenance Terminal The OMT is a terminal that supports functions for handling the RBS on site. The terminal can be a portable PC. |

| | |
|------------------|--|
| Operation | Operation is the normal, everyday running of the RBS with full functionality. |
| OPI | Operational Instructions |
| PA | Power Amplifier |
| PAM | Power Amplifier Module |
| PBA | Printed Board Assembly |
| PBC | Power and Battery Cabinet |
| PC | Personal Computer |
| PCB | Printed Circuit Board |
| PCH | Paging CHannel Downlink only subchannel of CCCH for system paging of MSs. -> CCCH |
| PCM | Pulse Coded Modulations (used as a name for the G.703 transmission interface) |
| PCS | Personal Communication Services |
| PFWD | Power Forward |
| Physical Channel | An air interface physical channel carries one or more logical channels. A physical channel uses a combination of frequency and time division multiplexing and is defined as a sequence of radio frequency channels and time slots. -> TDMA frame -> Logical channel |
| PIN | Personal Identification Number |
| PLB | Payload Loop Back |
| PREFL | Power Reflected |
| PSA | Power Supply Adapter |
| PSU | Power Supply Unit |
| RACH | Random Access CHannel Uplink only subchannel of CCCH for MS request for allocation of a dedicated channel. -> CCCH |
| RAI | Remote Alarm Indication |

| | |
|-------------|---|
| RAM | Random Access Memory |
| RBS | Radio Base Station All equipment forming one or more Ericsson base stations. ->BTS |
| RBS 2000 | New RBS generation |
| Remote mode | When the RU is in RU mode Remote, a link is established between the BCS and the central main RU. |
| RF | Radio Frequency |
| RLC | Repair Logistic Centre |
| R-state | Release state |
| RTN | Return |
| RU | Replaceable Unit An RU consists of one or more HWUs. An RU may be replaced by another RU of the same type. The RU is the smallest unit that can be handled on site. |
| RX | Receiver |
| RXA | Receiver antenna branch A |
| RXB | Receiver antenna branch B |
| RXDA | Receiver Divider Amplifier |
| RXDP | Receiver Distribution Plane |
| RXQUAL | Measure of signal quality as defined in GSM 05.08:8.2.4 |
| SES | Severely Errored Second |
| SIR | Small Indoor RBS |
| SO | Service Object |
| Sub RU | A sub-replaceable unit is always connected to a superior Main RU. This connection is used for example for retrieval of the RU identity. A sub-RU normally does not have a processor. Note that an RU with a processor that is not loadable is classified as a sub-RU. |
| SW | SoftWare |

| | |
|------------|--|
| SWR | Standing Wave Ratio |
| SYNC | Synchronous |
| T1 | Transmission facility for DS1 (1544 kbit/s). |
| TCB | Tranceiver Control Board |
| TCH | Traffic CHannel The traffic channels carry either encoded speech or user data. |
| TDMA | Time Division Multiple Access Multiplexing of several channels in a common frequency band. Each channel is assigned a certain time division, a time slot. |
| TDMA frame | GSM air interface time frame comprising eight time slots. |
| TEI | Terminal Endpoint Identifier TEI is an identification code carried by a LAPD frame as a terminal connection endpoint within a Service Access Point (SAP). |
| TEMS | TEst Mobile Station |
| TF | Timing Function |
| TG | Transceiver Group |
| Timing bus | The timing bus carries air timing information from the timing unit in the DXU to the TRUs. |
| TM | Transport Module |
| TMA | Tower Mounted Amplifier |
| TN O&M | Transport Network Operation and Maintenance (in general). |
| Tora | ASIC in the TRU |
| TRA | Transcoder Rate Adapter The TRA Unit in BSC performs transcoding of speech information and rate adaption of data information. |
| Tracy | ASIC in the TRU |

| | |
|--------|--|
| TRX | Transceiver (combined transmitter and receiver) |
| TS | Time Slot A 0.577 ms period (TDMA frame subunit) corresponding to 156.25 raw bits of information. The eight time slots of each TDMA frame are numbered 0...7. -> Burst |
| TT | Total Time |
| TX | Transmitter |
| TXA | Transmitter antenna branch A |
| TXB | Transmitter antenna branch B |
| TXU | Radio Transmitter Unit |
| UAS | Unavailable Seconds |
| UL | Underwriters Laboratories Inc. |
| Uplink | Signalling direction, from the MS to the system. |
| UPS | Uninterrupted Power Supply |
| VCO | Voltage Controlled Oscillator |
| VSWR | Voltage Standing Wave Ratio RF signal measure. The quotient between transmitted and reflected power. |
| X bus | The X bus carries transmit air data frames between transceivers. This is used for baseband frequency hopping. |